

APEX6152 & APEX6154 Servo Controller/Drive Quick Reference

TROUBLESHOOTING TIPS

- TO ALLOW MOTION:**
 - Power must be on. (Is at least one LED on?)
 - ENABLE IN must be grounded.
 - Connect (or disable) limits. LH (LH0) command.
 - Set (or disable) position error. SMPER (SMPER0)
 - Set reasonable gains for system. (see Tuning)
 - Check encoder (TPE); increments for CW move?
 - Check A, V, D. (If D = 0, no motion will occur.)
- EXAMINE LEDs** for indication of problem. pg 60
- PROBLEM REPORT:** TAS command reports problems. TFS command reports Following status.
- INPUTS or OUTPUTS not working:**
 - Programmable input (INFNC) functions and drive fault detection will not operate until you enable input functions with the INFEN1 command.
 - Programmable output (OUTFNC) functions will not operate unless enabled with OUTFEN1 command.

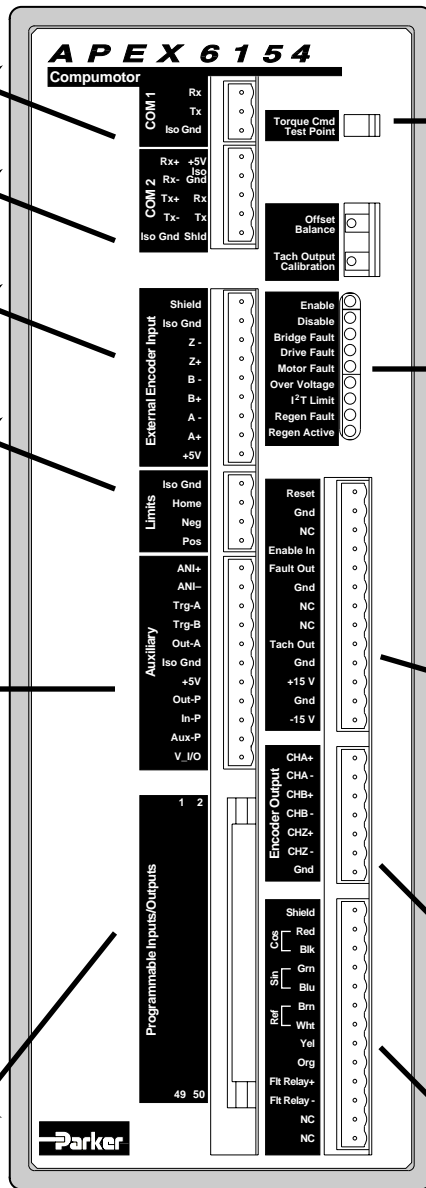
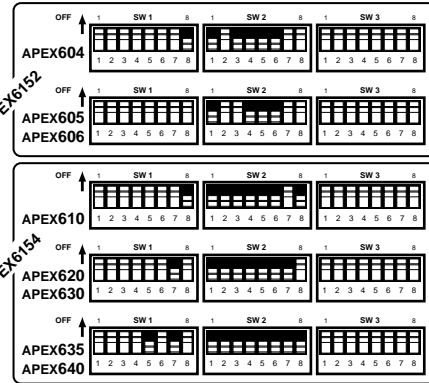
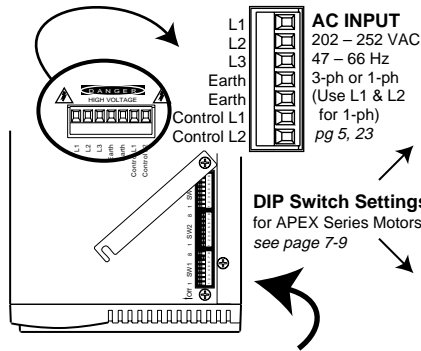

TEST POINT

APEX6152 1 volt = 3 amps cmd. torque
APEX6154 1 volt = 5 amps cmd. torque
see page 69

LEDs

Name	Description/Problem pg 60
Enable	Indicates drive is enabled.
Disable	Indicates drive is disabled.
Bridge Fault	Power stage overtemp. Power stage overcurrent.
Drive Fault	Motor short circuit. Control board overtemp. Undervoltage (brownout).
Motor Fault	Resolver not connected. Motor overtemperature. Motor thermostat not connected.
Over Voltage	Bus voltage exceeded 420VDC.
I2T Limit	I2t Limit exceeded. Drive is in foldback. Output limited to continuous current setting.
Regen Fault	Drive faulted—excess regen.
Regen Active	Regen resistor on, and dissipating excess power.

DRIVE AUXILIARY CONNECTOR

RESET	Active Low, ≤1.0V pg 34, 62
GND	Internally isolated from EARTH terminal. see page 18, 19
ENABLE IN	Active Low, ≤1.0V page 35, 63
FAULT OUT	Active HIGH (floats if faulted) (Output is held low if no fault) page 35
TACH OUT	1V/1000 rpm for 1-speed resolver. Scale by DIP SW3-#5 page 36, 70
±15V	10 mA at ±15V page 36

ENCODER OUTPUT

Counts/Rev: 1024 counts, pre-quadrature
4096 counts, post-quadrature
CW Rotation: Ch A leads Ch B
Ch Z: Ch Z pulse width is 90°
pg 37, 38

RESOLVER CONNECTOR

Resolver:	Resolution is 4096 counts/rev
Color Code:	Connector Wire Color
APEX	Shield -----
Resolver	Stator 3 Red
Cable	Stator 1 Black
	Stator 2 Green
	Stator 4 Blue
	Rotor 1 Brown
	Rotor 2 White
	Motor Temp+ Yellow
	Motor Temp- Orange
MT±:	Short MT+ and MT- if motor has no temperature sensor pg 41
Fit Relay:	Relay type: Normally Open Max Current: 5A at 24VDC or 5A at 120VAC see page 42 for more info see Motor Braking on pg 42-44

COM 1

Set-up: 9600 baud, 8 data bits, 1 stop bit, no parity, full duplex. see page 25

COM 2

Connections – see pages 25 & 32
Configuring for RS-485 – see page 10

EXTERNAL ENCODER INPUT

Optically isolated. Encoder must be: Incremental; 2-ph. quadrature; differential (recommended) or single-ended; HCMOS compatible*; Max. freq.=1.2MHz; Min. between transitions = 833 ns. see page 26

LIMITS

Home, Pos, Neg: V_I/O sets switching voltage levels; internal 6.8 KΩ pull-ups through AUX-P to 5V or ext. 0–24V supp. see pg 27

AUXILIARY

Name	Description
ANI+	Analog Input. Not applicable.
ANI-	
TRG-A	Input #17. Optically isolated. Internal 6.8 KΩ pull-ups through AUX-P to 5V or external 0–24V. see pg 28. Use for position capture input (INFNC).
TRG-B	General purpose input #18. Otherwise same as Trg-A.
OUT-A	Output #9. Use for output on position (OUTFNC). Circuit identical to prog. outputs. pg 28, 29
ISO GND	Isolated ground. see pg 18, 19
+5V	Connect to OUT-P, IN-P, and/or AUX-P to power I/O. 100mA limit. see pg 27, 28, 30, 31
OUT-P	Pull-up resistors for prog. outputs and OUT-A. pg 29, 31
IN-P	Pull-up resistors for programmable inputs. pg 29, 31
AUX-P	Pull-up resistors for Home, Neg, Pos, Trg-A, Trg-B pg 27, 28, 30

Connect V_I/O, Out-P, In-P, Aux-P to +5V for HCMOS compatibility.* Connect to 0 – 24V supply for other compatibility. pg 5, 6, 27-31

PROGRAMMABLE I/O

Pin	I/O Number	Pin	I/O Number
1	Input #16	25	Input #8
3	Input #15	27	Input #7
5	Input #14	29	Input #6
7	Input #13	31	Input #5
9	Input #12	33	Output #4
11	Input #11	35	Output #3
13	Input #10	37	Output #2
15	Input #9	39	Output #1
17	Output #8	41	Input #4
19	Output #7	43	Input #3
21	Output #6	45	Input #2
23	Output #5	47	Input #1
		49	+5VDC

Even numbered pins connect to ISO GND.
I/O are: optically isolated; HCMOS compatible.* Plug is compatible with OPTO-22.
INPUTS: Connect internal 6.8KΩ pull-ups through In-P to +5V or 0 – 24V supply.
OUTPUTS: Open-collector outputs. Connect internal 4.7KΩ pull-ups through Out-P to +5V or 0 – 24V supply.
See I/O Device Interface – pages 29-31

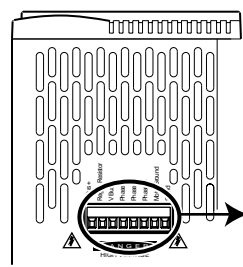

Color Code	APEX Motor Cable
V Bus +	Orange
Regen Res/NC	Blue
V Bus -	Blue
Phase A	Blue
Phase B	Blue
Phase C	Gray
Motor Ground	Green & Shield
Shield	Shield

*HCMOS-compatibility: Low ≤ 1.0V, High ≥ 3.25V
**Optical isolation between I/O GND and internal microprocessor ground, but not between inputs and outputs.