



A Full Line Up of Powerful Servos to Meet the Demands of Your Application!

Compumotor began manufacturing brushless servo motors with the release of the SM series in the spring of 1995. Since that time, we have continued to expand our product offering and have manufacturing plants in California and Italy.

Innovation in Design

Compumotor utilizes two distinct technologies in the manufacturing of brushless servo motors. The Slotless Design and the Bridged Stator Design both reduce motor manufacturing costs while providing performance advantages to the user.

The slotless design eliminates all detent torque in the motor, providing superior performance in applications requiring smooth, low speed operation. This design also results in higher rotor inertia, providing an advantage in applications involving high inertia loads.

The bridged stator design results in extremely high torque-to-

inertia ratios, providing a performance advantage in applications requiring high accelerations. The bridged stator design also greatly reduces detent torque and mechanical noise when compared to a conventional slotted motor.

Compumotor can also provide an integrated planetary gearhead for use with our brushless servo motors. Our unique design integrates the pinion of the gearhead into the motor shaft, reducing total package length by almost two inches.

Standards or Specials in 10 Days

Compumotor's brushless servo motors are manufactured in our modern JIT manufacturing facility. Highly evolved manufacturing philosophies provide levels of service and product availability previously unattainable in the servo motor industry.

Compumotor's lead times average less than ten days for all standard and custom servo motors.

SM Series



- Size 16 and 23
- 0.8 to 11.3 in.-lb. continuous torque
- Slotless design
- Rugged housing (IP65 option)
- Connection options

SE Series



- Size 16 and 23
- 0.8 to 10.1 in.-lb. continuous torque
- Slotless design
- Plastic encoder cover
- Short package length

BE Series



- Size 16, 23 and 34
- 1.4 to 46 in.-lb. continuous torque
- Bridged stator design
- 2000-line encoder standard
- Connection options

M Series



- Size 105, 145 and 205mm
- Up to 90 Nm of power
- Brushless construction
- Encoder feedback and resolver

Planetary Gearheads



- Size 16, 23, 34 and 92
- Integrated pinion design
- Shortest package length available

NeoMetric & J Series



- 70 mm and 92 mm
- 6 to 61 in.-lb. continuous torque
- Bridged stator design
- Rugged housing (IP65 option)
- Connection options

SL Series



- Size 42, 63, 102 and 140mm
- 20 to 350 lbs continuous force
- Slotless design
- High speeds
- High precision

Custom Designed Servo Motors for Your Specific Application!

Compumotor offers a broad range of standard options with all of our brushless servo motor families. Our numerous shaft, feedback and connection options will fulfill the needs of most of our customers. However, we realize that from time to time the need arises to have a custom motor designed specially for your application.

Whether you need custom connectors, mounting, or a custom winding, Compumotor can build a motor designed to your exact specifications. Compumotor provides these special designs for our customers with:

- Minimal impact on product lead time
- Modest impact on pricing
- No minimum quantities

Compumotor's modern manufacturing system allows us to offer custom motor solutions without sacrificing product quality and availability. All of our custom motors are built in our standard servo motor work cell, and our computerized custom product tracking system allows us to provide consistent, high-quality custom products. And, because custom motor manufacturing is integrated into our standard manufacturing process, we can often build and ship custom designed motors and cables in the same time frame as standard products.

Compumotor provides this service for one simple reason: to make it easier for you, our customer, to integrate a Compumotor servo motor into your application. We provide more than just a component, we provide a custom designed servo motor solution.

Common Special Requests

Connectorization

- Right angle connector housing
- MS connectors on back cover
- Special cable lengths
- Hi-flex cables
- Customer specified cables and connectors
- Cable exiting through back cover

Flanges

- Tapped mounting holes
- Customer specified flanges
- Face mount

Gearheads

- Non-standard ratios
- Customer specified flanges
- Customer specified output shaft

Windings:

- Specific bus voltage

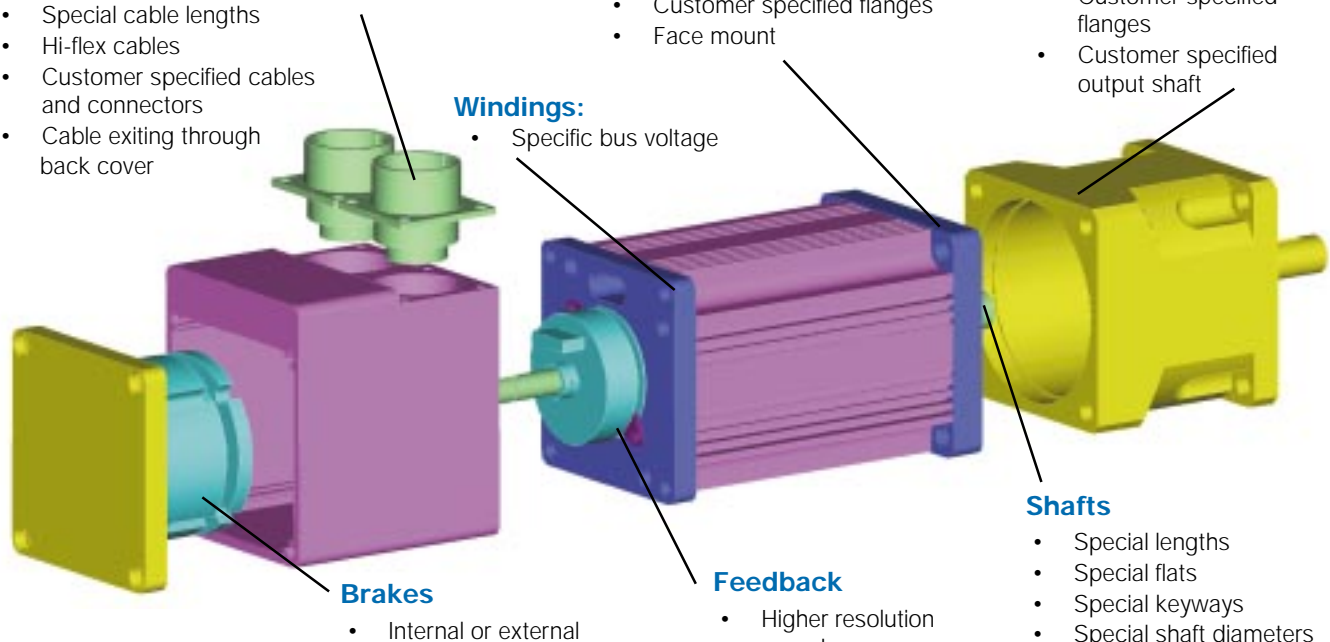

Brakes

- Internal or external

Feedback

- Higher resolution encoders
- Higher temperature encoders

Shafts

- Special lengths
- Special flats
- Special keyways
- Special shaft diameters
- Metric shaft diameters
- Hollow shafts
- Rear Shaft Extension
- Double flats
- Shaft pinning
- Pressed on gears
- Center tapped
- Special shaft materials

Miscellaneous Options

- Private label back cover
- Special windings
- Shorter lengths
- High speed balancing
- Special finish



Custom Designed Servo Motors For Your Specific Application. Call 1-800-358-9070 Today.

BE Series Motors



High-Torque Design, Low-Cost Package

Compumotor's BE Series brushless servo motors produce high continuous stall torque in a cost-reduced package.

The increased torque of the BE Series motors is the result of an increased number of magnetic poles on the rotor. Traditional motors in these frame sizes have four magnetic poles on the rotor, while the BE Series motors have eight poles.

The cost reduction of the BE Series motors is achieved from their open lamination design. Unlike traditional servo motors, the BE Series motors do not have a metal housing. Instead, the laminations of the motor stator are shaped into the body of the motor. This design reduces both material costs and time required assembling the motor.

The BE Series motors are created using Compumotor's proven bridged stator design. This two-piece lamination design simplifies the manufacturing process, creating further cost savings. The bridged stator construction also results in less audible noise being generated by the motor.

The BE Series servo motors are available with integrated planetary gearheads in ratios up to 100:1. Our unique package integrates the gearhead pinion into the motor shaft, reducing the overall package length by up to 2 inches.

Features

- Size 16, 23 and 34
- 1.4 to 46 lb-in continuous torque
- Brushless construction
- High torque density packaging
- Bridged stator design - quiet operation
- High performance neodymium magnets
- Thermoswitch protection
- 2000 line encoder standard
- Resolver feedback option
- Connectorization choices
- 10-day deliveries
- Two year warranty
- CAD (.dxf) drawings available
- CE compliant

Part Numbering System

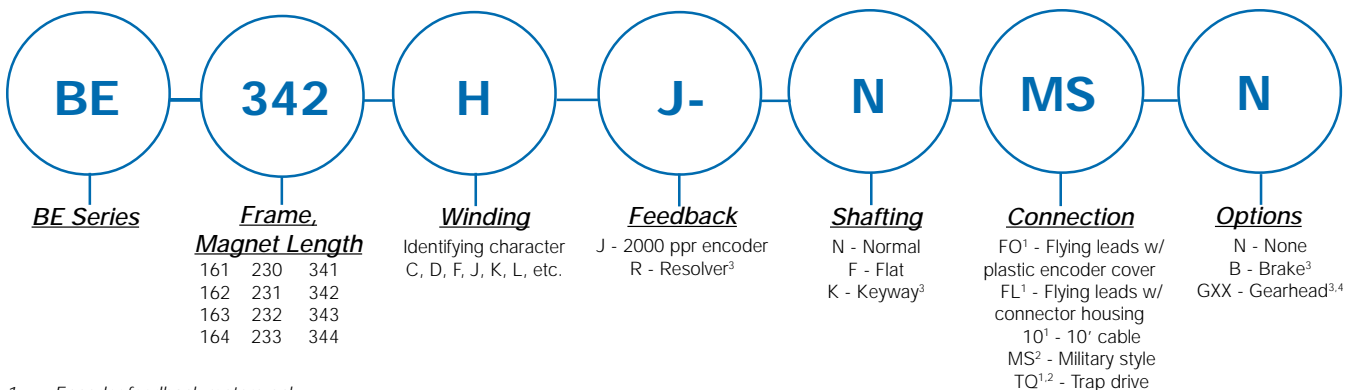

1 Encoder feedback motors only
2 Refer to "Wiring and Cable Specifications" section for connector wiring
3 Not available on size 16
4 Specify "K" shaft option with gearheads

Custom Designed Servo Motors For Your Specific Application. Call 1-800-358-9070 Today.

Size 16, Encoder Feedback, Specifications

Parameter	Symbol	Units	BE161C	BE161D	BE161F	BE162C	BE162D	BE162F
Stall Torque Continuous ¹	T_{cs}	lb-in	1.3	1.4	1.4	2.3	2.5	2.4
		oz-in	21	23	22	37	39	39
		Nm	0.15	0.16	0.15	0.26	0.28	0.27
Stall Current Continuous ^{1,4,8}	$I_{cs}(\text{sine})$	Amps Peak	2.9	4.6	6.9	3.0	4.5	6.8
Stall Current Continuous ^{1,7}	$I_{cs}(\text{trap})$	Amps DC	2.5	4.0	6.0	2.6	3.9	5.9
Peak Torque ⁶	T_{pk}	lb-in	4.0	4.2	4.1	6.9	7.4	7.2
		oz-in	64	68	66	111	118	116
		Nm	0.45	0.47	0.46	0.78	0.83	0.81
Peak Current ^{4,6,8}	$I_{pk}(\text{sine})$	Amps Peak	8.6	13.7	20.8	9.1	13.4	20.4
Peak Current ^{6,7}	$I_{pk}(\text{trap})$	Amps DC	7.4	11.9	18.0	7.9	11.6	17.7
Rated Speed ²	w_r	rpm	5000	5000	5000	5000	5000	5000
Current @ Rated Speed	$I_r(\text{sine})$	Amps Peak	2.8	4.5	6.9	3.0	4.4	6.7
Current @ Rated Speed	$I_r(\text{trap})$	Amps	2.5	3.9	5.9	2.6	3.8	5.8
Torque @ Rated Speed	T_r	lb-in	1.3	1.4	1.3	2.2	2.4	2.4
		oz-in	21	22	21	36	38	38
		Nm	0.14	0.15	0.15	0.25	0.27	0.26
Shaft Power @ Rated Speed	P_o	watts	76	80	78	131	140	140
Voltage Constant ^{3,4}	K_b	Volts/rad/s	0.061	0.040	0.026	0.100	0.072	0.046
Voltage Constant ^{3,4}	K_e	Volts/Krpm	6.38	4.22	2.69	10.42	7.55	4.85
Torque Constant ⁹	$K_t(\text{sine})$	oz-in/Amp Peak	7.47	4.94	3.15	12.20	8.84	5.68
		Nm/Amp Peak	0.052	0.035	0.022	0.085	0.062	0.040
Torque Constant ^{3,4}	$K_t(\text{trap})$	oz-in/Amp DC	8.62	5.71	3.64	14.09	10.21	6.56
		Nm/Amp DC	0.060	0.040	0.025	0.099	0.071	0.046
Resistance ³	R	Ohms	4.31	1.71	0.74	4.38	2.03	0.87
Inductance ⁵	L	mH	12.10	5.30	2.16	16.14	8.46	3.50
Maximum Bus Voltage	V_m	Volts DC	340	170	170	340	170	170
Thermal Res Wind-Amb	$R_{th,w-a}$	°C/watt	2.70	2.70	2.70	2.37	2.37	2.37
Motor Constant	K_m	oz-in/ $\sqrt{\text{watt}}$	4.15	4.36	4.23	6.73	7.17	7.03
		Nm/ $\sqrt{\text{watt}}$	0.029	0.031	0.030	0.047	0.050	0.049
Viscous Damping	B	oz-in/Krpm	0.050	0.050	0.050	0.060	0.060	0.060
		Nm/Krpm	3.5E-04	3.5E-04	3.5E-04	4.2E-04	4.2E-04	4.2E-04
Static Friction	T_f	oz-in	0.25	0.25	0.25	0.40	0.40	0.40
		Nm	1.8E-03	1.8E-03	1.8E-03	2.8E-03	2.8E-03	2.8E-03
Motor Thermal Time Constant	t_{th}	minutes	8.3	8.3	8.3	8.3	8.3	8.3
Electrical Time Constant	t_{elec}	milliseconds	2.81	3.10	2.92	3.68	4.17	4.02
Mechanical Time Constant	t_{mch}	milliseconds	1.4	1.3	1.4	0.9	0.8	0.8
Intermittent Torque Duration ¹⁰	T_{2x}	seconds	27	27	27	39	39	39
Peak Torque Duration ¹¹	T_{3x}	seconds	11	11	11	16	16	16
Rotor Inertia	J	lb-in-sec ²	1.1E-05	1.1E-05	1.1E-05	1.8E-05	1.8E-05	1.8E-05
		kg-m ²	1.2E-06	1.2E-06	1.2E-06	2.0E-06	2.0E-06	2.0E-06
Number of Poles	N_p		8	8	8	8	8	8
Motor Weight	#	lbs	0.6	0.6	0.6	0.8	0.8	0.8
		kg	0.3	0.3	0.3	0.3	0.3	0.3
Winding Class			H	H	H	H	H	H

¹ @ 25°C ambient, 125°C winding temperature, motor connected to a 10"x10"x1/4" aluminum mounting plate.

² @40°C ambient derate phase currents and torques by 6%.
Maximum speed is 5000 RPM. For higher speed operation please call the factory.

³ Measured Line to Line, +/- 10%.

⁴ Value is measured peak of sine wave.

⁵ +/-30%, Line-to-Line, inductance bridge measurement @1Khz.

⁶ Initial winding temperature must be 60°C or less before peak current is applied.

⁷ DC current through a pair of motor phases of a trapezoidally (six state) commutated motor.

⁸ Peak of the sinusoidal current in any phase for a sinusoidally commutated motor.

⁹ Total motor torque per peak of the sinusoidal amps measured in any phase, +/-10%.

¹⁰ Maximum time duration with 2 times rated current applied with initial winding temp at 60°C.

¹¹ Maximum time duration with 3 times rated current applied with initial winding temp at 60°C.

Note: These specifications are based on theoretical motor performance and are not specific to any amplifier.

Size 16, Encoder Feedback, Specifications

Parameter	Symbol	Units	BE163C	BE163D	BE163F	BE164C	BE164D	BE164F
Stall Torque Continuous ¹	T_{cs}	lb-in	2.9	3.0	3.0	3.6	3.8	3.8
		oz-in	47	48	48	58	61	61
		Nm	0.33	0.34	0.33	0.40	0.43	0.42
Stall Current Continuous ^{1,4,8}	$I_{cs}(\text{sine})$	Amps Peak	2.9	4.0	6.3	3.0	3.8	6.0
Stall Current Continuous ^{1,7}	$I_{cs}(\text{trap})$	Amps DC	2.5	3.5	5.4	2.6	3.3	5.2
Peak Torque ⁶	T_{pk}	lb-in	8.8	9.1	8.9	10.8	11.4	11.4
		oz-in	142	145	143	173	183	182
		Nm	0.99	1.01	1.00	1.21	1.28	1.27
Peak Current ^{4,6,8}	$I_{pk}(\text{sine})$	Amps Peak	8.6	12.1	18.8	9.1	11.4	18.0
Peak Current ^{6,7}	$I_{pk}(\text{trap})$	Amps DC	7.5	10.5	16.3	7.9	9.9	15.6
Rated Speed ²	w_r	rpm	5000	5000	5000	5000	5000	5000
Current @ Rated Speed	$I_r(\text{sine})$	Amps Peak	2.8	3.9	6.1	2.9	3.7	5.8
Current @ Rated Speed	$I_r(\text{trap})$	Amps	2.4	3.4	5.3	2.5	3.2	5.0
Torque @ Rated Speed	T_r	lb-in	2.8	2.9	2.8	3.4	3.6	3.6
		oz-in	45	46	45	54	57	57
		Nm	0.31	0.32	0.32	0.38	0.40	0.40
Shaft Power @ Rated Speed	P_o	watts	165	169	166	200	212	211
Voltage Constant ^{3,4}	K_b	Volts/rad/s	0.134	0.098	0.062	0.154	0.130	0.082
Voltage Constant ^{3,4}	K_e	Volts/Krpm	14.01	10.24	6.47	16.17	13.66	8.63
Torque Constant ⁹	$K_t(\text{sine})$	oz-in/Amp Peak	16.41	11.99	7.58	18.93	15.99	10.10
		Nm/Amp Peak	0.115	0.084	0.053	0.133	0.112	0.071
		oz-in/Amp DC	18.95	13.85	8.75	21.86	18.46	11.67
Torque Constant ^{3,4}	$K_t(\text{trap})$	Nm/Amp DC	0.133	0.097	0.061	0.153	0.129	0.082
Resistance ³	R	Ohms	4.77	2.42	1.00	4.65	2.98	1.20
Inductance ⁵	L	mH	19.45	10.39	4.15	19.43	13.86	5.53
Maximum Bus Voltage	V_m	Volts DC	340	170	170	340	170	170
Thermal Res Wind-Amb	$R_{th} w-a$	°C/watt	2.43	2.43	2.43	2.21	2.21	2.21
Motor Constant	K_m	oz-in/√watt	8.67	8.90	8.75	10.14	10.70	10.65
		Nm/√watt	0.061	0.062	0.061	0.071	0.075	0.075
Viscous Damping	B	oz-in/Krpm	0.070	0.070	0.070	0.080	0.080	0.080
		Nm/Krpm	4.9E-04	4.9E-04	4.9E-04	5.6E-04	5.6E-04	5.6E-04
Static Friction	T_f	oz-in	0.60	0.60	0.60	0.80	0.80	0.80
		Nm	4.2E-03	4.2E-03	4.2E-03	5.6E-03	5.6E-03	5.6E-03
Motor Thermal Time Constant	t_{th}	minutes	10.0	10.0	10.0	11.6	11.6	11.6
Electrical Time Constant	t_{elec}	millisecs	4.08	4.29	4.15	4.18	4.65	4.61
Mechanical Time Constant	t_{mch}	millisecs	0.7	0.7	0.7	0.7	0.6	0.6
Intermittent Torque Duration ¹⁰	T_{2x}	seconds	52	52	52	58	58	58
Peak Torque Duration ¹¹	T_{3x}	seconds	20	20	20	23	23	23
Rotor Inertia	J	lb-in-sec ²	2.4E-05	2.4E-05	2.4E-05	3.1E-05	3.1E-05	3.1E-05
		kg-m ²	2.7E-06	2.7E-06	2.7E-06	3.5E-06	3.5E-06	3.5E-06
Number of Poles	N_p		8	8	8	8	8	8
Motor Weight	#	lbs	1.1	1.1	1.1	1.3	1.3	1.3
		kg	0.5	0.5	0.5	0.6	0.6	0.6
Winding Class			H	H	H	H	H	H

¹ @ 25°C ambient, 125°C winding temperature, motor connected to a 10"x10"x1/4" aluminum mounting plate.
² @40°C ambient derate phase currents and torques by 6%. Maximum speed is 5000 RPM. For higher speed operation please call the factory.
³ Measured Line to Line, +/- 10%.
⁴ Value is measured peak of sine wave.
⁵ +/-30%, Line-to-Line, inductance bridge measurement @1Khz.
⁶ Initial winding temperature must be 60°C or less before peak current is applied.

⁷ DC current through a pair of motor phases of a trapezoidally (six state) commutated motor.
⁸ Peak of the sinusoidal current in any phase for a sinusoidally commutated motor.
⁹ Total motor torque per peak of the sinusoidal amps measured in any phase, +/-10%.
¹⁰ Maximum time duration with 2 times rated current applied with initial winding temp at 60°C.
¹¹ Maximum time duration with 3 times rated current applied with initial winding temp at 60°C.

Note: These specifications are based on theoretical motor performance and are not specific to any amplifier.

Custom Designed Servo Motors For Your Specific Application. Call 1-800-358-9070 Today.

Size 16, Encoder Feedback, Performance Curves

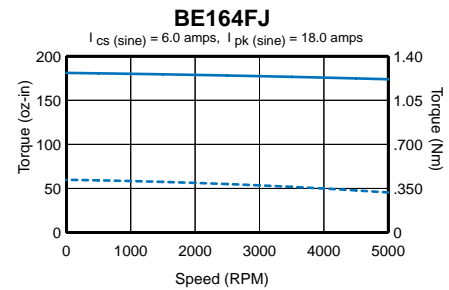
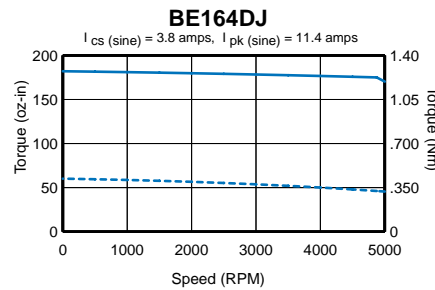
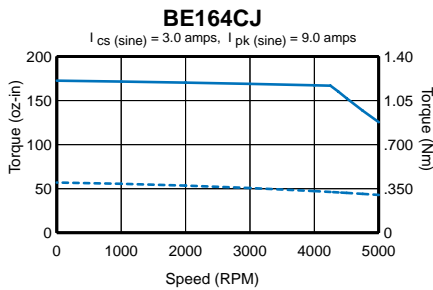
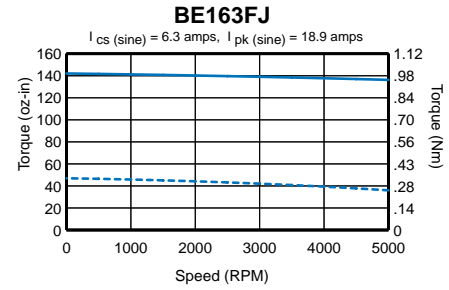
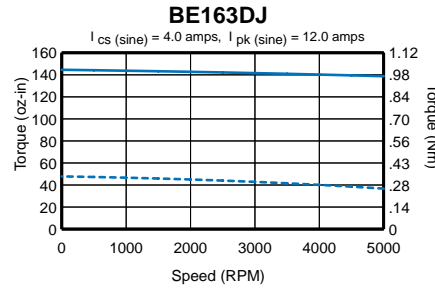
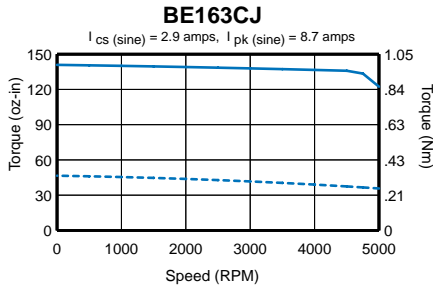
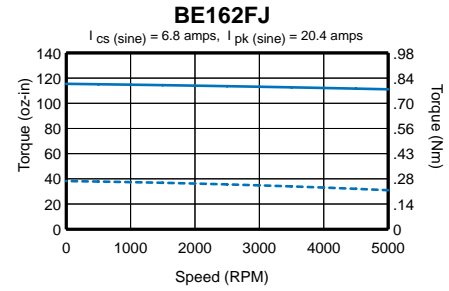
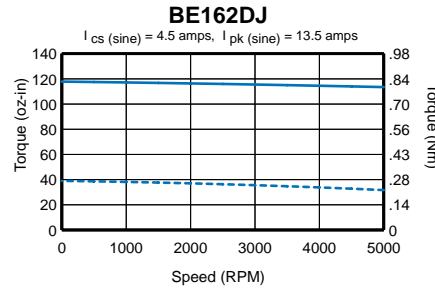
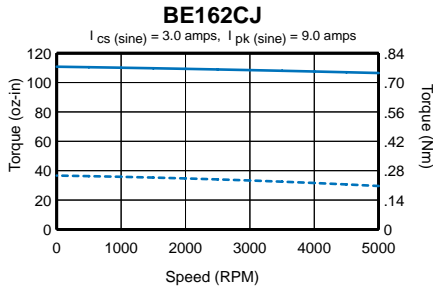
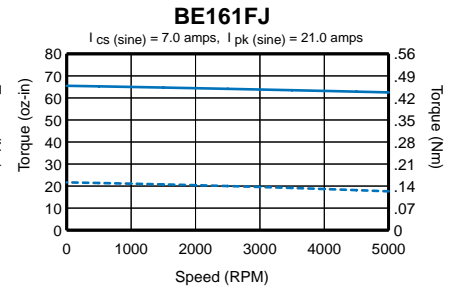
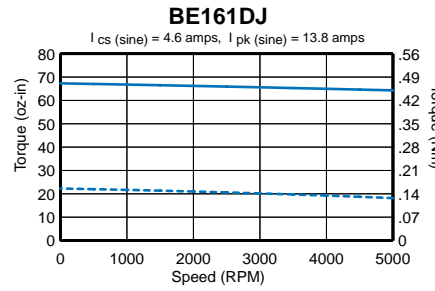
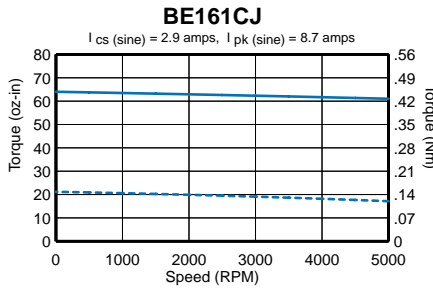

--- CONTINUOUS
— PEAK
(170VDC)

Size 23, Encoder Feedback, Specifications

Parameter	Symbol	Units	BE230D	BE230F	BE231D	BE231F	BE232D	BE232F	BE233D	BE233F
Stall Torque Continuous ¹	T_{cs}	lb-in	3.4	3.3	6.0	5.9	9.9	9.7	13.0	13.3
		oz-in	54	53	96	94	159	155	207	213
		Nm	0.38	0.37	0.67	0.66	1.11	1.08	1.45	1.49
Stall Current Continuous ^{1,4,8}	$I_{cs}(\text{sine})$	Amps Peak	3.1	6.1	2.8	5.3	2.8	5.4	2.5	4.9
Stall Current Continuous ^{1,7}	$I_{cs}(\text{trap})$	Amps DC	2.7	5.3	2.4	4.6	2.4	4.7	2.2	4.2
Peak Torque ⁶	T_{pk}	lb-in	10.1	10.0	18.0	17.7	29.7	29.0	38.9	40.0
		oz-in	161	160	289	283	476	464	622	640
		Nm	1.13	1.12	2.02	1.98	3.33	3.25	4.35	4.48
Peak Current ^{4,6,8}	$I_{pk}(\text{sine})$	Amps Peak	9.4	18.2	8.2	15.9	8.4	16.3	7.4	14.6
Peak Current ^{6,7}	$I_{pk}(\text{trap})$	Amps DC	8.1	15.8	7.1	13.8	7.3	14.1	6.5	12.7
Rated Speed ²	ω_r	rpm	5000	5000	5000	5000	5000	5000	3750	5000
Current @ Rated Speed	$I_r(\text{sine})$	Amps Peak	2.9	5.6	2.5	4.7	2.4	4.7	2.2	4.0
Current @ Rated Speed	$I_r(\text{trap})$	Amps	2.5	4.8	2.1	4.1	2.1	4.1	1.9	3.5
Torque @ Rated Speed	T_r	lb-in	2.9	2.9	5.2	5.1	8.2	8.0	11.3	10.7
		oz-in	47	47	83	81	131	128	180	171
		Nm	0.33	0.33	0.58	0.57	0.92	0.90	1.26	1.20
Shaft Power @ Rated Speed	P_o	watts	174	174	307	300	484	473	499	632
Voltage Constant ^{3,4}	K_b	Volts/rad/s	0.140	0.072	0.286	0.145	0.461	0.232	0.681	0.357
Voltage Constant ^{3,4}	K_e	Volts/Krpm	14.66	7.53	29.90	15.18	48.28	24.29	71.30	37.41
Torque Constant ⁹	$K_t(\text{sine})$	oz-in/Amp Peak	17.17	8.82	35.01	17.78	56.53	28.45	83.50	43.80
		Nm/Amp Peak	0.120	0.062	0.245	0.124	0.396	0.199	0.584	0.307
		oz-in/Amp DC	19.82	10.18	40.43	20.53	65.28	32.85	96.42	50.58
Torque Constant ^{3,4}	$K_t(\text{trap})$	Nm/Amp DC	0.139	0.071	0.283	0.144	0.457	0.230	0.675	0.354
Resistance ³	R	Ohms	4.57	1.22	6.97	1.86	7.72	2.05	10.98	2.85
Inductance ⁵	L	mH	15.43	4.10	32.30	8.65	42.66	11.12	61.39	16.28
Maximum Bus Voltage	V_m	Volts DC	340	340	340	340	340	340	340	340
Thermal Res Wind-Amb	$R_{th, w-a}$	°C/watt	2.14	2.14	1.82	1.82	1.58	1.58	1.41	1.41
Motor Constant	K_m	oz-in/√watt	9.27	9.22	15.31	15.05	23.49	22.94	29.10	29.96
		Nm/√watt	0.065	0.065	0.107	0.105	0.164	0.161	0.204	0.210
Viscous Damping	B	oz-in/Krpm	0.3	0.3	0.4	0.4	0.5	0.5	0.7	0.7
		Nm/Krpm	1.8E-03	1.8E-03	2.5E-03	2.5E-03	3.5E-03	3.5E-03	4.9E-03	4.9E-03
Static Friction	T_f	oz-in	0.8	0.8	1.3	1.3	2.0	2.0	2.5	2.5
		Nm	5.3E-03	5.3E-03	8.8E-03	8.8E-03	1.4E-02	1.4E-02	1.8E-02	1.8E-02
Motor Thermal Time Constant	τ_{th}	minutes	11.6	11.6	13.3	13.3	15.0	15.0	20.0	20.0
Electrical Time Constant	τ_{elec}	millisecs	3.38	3.36	4.63	4.65	5.53	5.42	5.59	5.71
Mechanical Time Constant	τ_{mch}	millisecs	1.2	1.2	0.8	0.8	0.6	0.6	0.6	0.5
Intermittent Torque Duration ¹⁰	T_{2x}	seconds	37	37	47	47	58	58	62	62
Peak Torque Duration ¹¹	T_{3x}	seconds	15	15	18	18	22	22	23	23
Rotor Inertia	J	lb-in-sec ²	4.6E-05	4.6E-05	8.0E-05	8.0E-05	1.5E-04	1.5E-04	2.1E-04	2.1E-04
		kg-m ²	5.2E-06	5.2E-06	9.0E-06	9.0E-06	1.7E-05	1.7E-05	2.4E-05	2.4E-05
Number of Poles	Np		8	8	8	8	8	8	8	8
Motor Weight	#	lbs	1.5	1.5	2.0	2.0	3.1	3.1	4.2	4.2
		kg	0.7	0.7	0.9	0.9	1.4	1.4	1.9	1.9
Winding Class			H	H	H	H	H	H	H	H

¹ @ 25°C ambient, 125°C winding temperature, motor connected to a 10"x10"x1/4" aluminum mounting plate.
² @40°C ambient derate phase currents and torques by 12%.
³ Operation with 340 VDC bus. Maximum speed is 5000 RPM. For higher speed operation please call the factory.
⁴ Measured Line to Line, +/- 10%.
⁵ Value is measured peak of sine wave.
⁶ +/-30%, Line-to-Line, inductance bridge measurement @1Khz.
⁷ Initial winding temperature must be 60°C or less before peak current is applied.

⁸ DC current through a pair of motor phases of a trapezoidally (six state) commutated motor.
⁹ Peak of the sinusoidal current in any phase for a sinusoidally commutated motor.
¹⁰ Total motor torque per peak of the sinusoidal amps measured in any phase, +/-10%.
¹¹ Maximum time duration with 2 times rated current applied with initial winding temp at 60°C.
 Maximum time duration with 3 times rated current applied with initial winding temp at 60°C.

Note: These specifications are based on theoretical motor performance and are not specific to any amplifier.

Custom Designed Servo Motors For Your Specific Application. Call 1-800-358-9070 Today.

Size 23, Encoder Feedback, Performance Curves

BE230DJ

Ics (sine)=3.1 amps, Ipk(sine)=9.4 amps

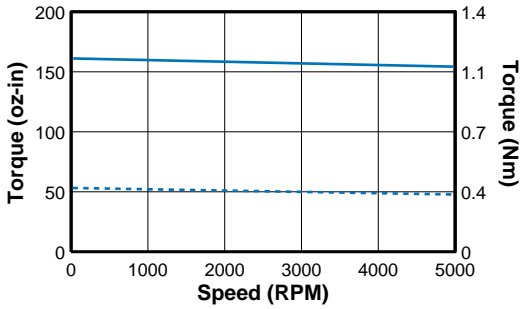

BE230FJ

Ics (sine)=6.1 amps, Ipk(sine)=18.2 amps

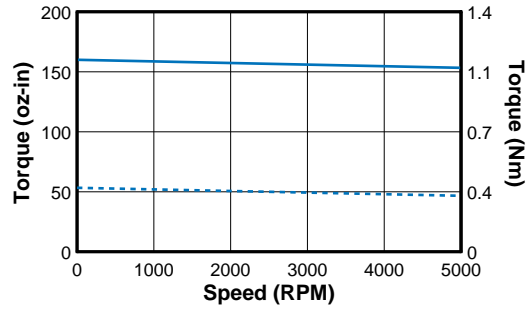

BE231DJ

Ics (sine)=2.8 amps, Ipk(sine)=8.2 amps

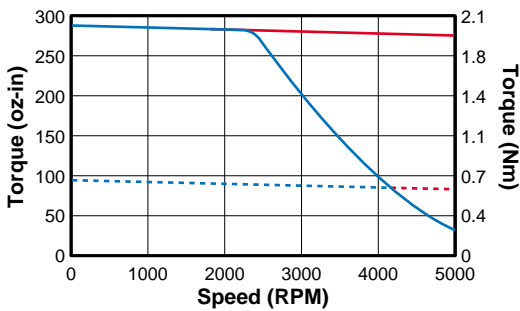

BE231FJ

Ics (sine)=5.3 amps, Ipk(sine)=15.9 amps

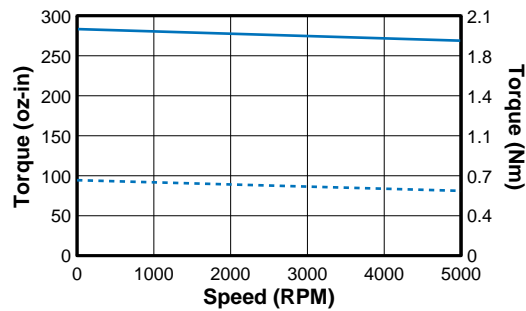

BE232DJ

Ics (sine)=2.8 amps, Ipk(sine)=8.4 amps

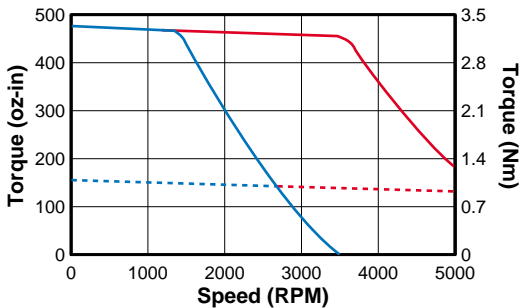

BE232FJ

Ics (sine)=5.4 amps, Ipk(sine)=16.3 amps

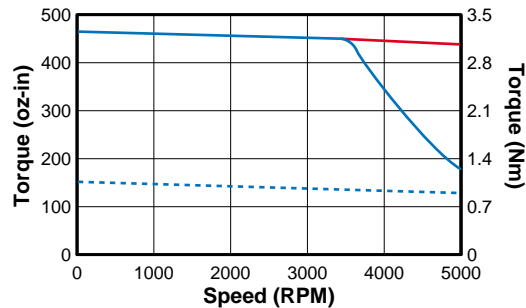

BE233DJ

Ics (sine)=2.5 amps, Ipk(sine)=7.5 amps

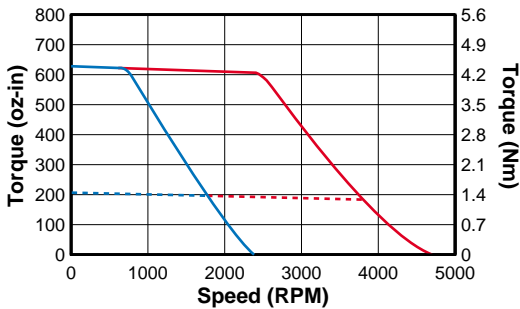

BE233FJ

Ics (sine)=4.9 amps, Ipk(sine)=14.6 amps

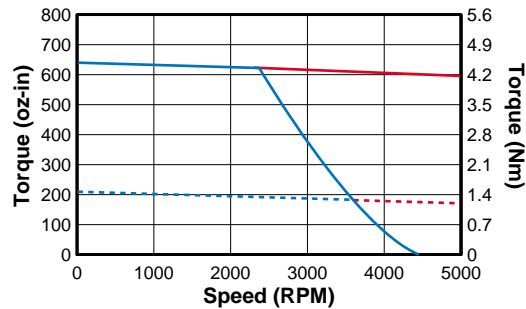

----- ——— ----- ———
 CONTINUOUS PEAK CONTINUOUS PEAK
 170 VDC 340 VDC

Size 23, Resolver Feedback, Specifications

Parameter	Symbol	Units	BE230D	BE230F	BE231D	BE231F	BE232D	BE232F	BE233D	BE233F	
Stall Torque Continuous ¹	T_{cs}	lb-in	3.6	3.6	6.5	6.4	10.7	10.5	14.0	14.4	
		oz-in	58	58	104	102	171	167	225	231	
		Nm	0.41	0.40	0.73	0.71	1.20	1.17	1.57	1.61	
Stall Current Continuous ^{1,4,8}	$I_{cs}(\text{sine})$	Amps Peak	3.4	6.6	3.0	5.7	3.0	5.9	2.7	5.3	
		Peak Torque ⁶	lb-in	10.9	10.8	19.5	19.1	32.1	31.4	42.1	43.2
			oz-in	174	173	312	306	513	502	674	692
Peak Current ^{4,6,8}	$I_{pk}(\text{sine})$	Nm	1.22	1.21	2.18	2.14	3.59	3.51	4.72	4.84	
		Amps Peak	10.1	19.7	8.9	17.2	9.1	17.6	8.1	15.8	
		Rated Speed ²	ω_r	rpm	5000	5000	5000	5000	5000	5000	3625
Current @ Rated Speed	$I_r(\text{sine})$	Amps Peak	3.2	6.1	2.7	5.3	2.7	5.2	2.5	4.6	
Torque @ Rated Speed	T_r	lb-in	3.3	3.3	5.8	5.6	9.3	9.0	12.6	12.1	
		oz-in	52	52	92	90	148	144	201	194	
		Nm	0.36	0.36	0.64	0.63	1.04	1.01	1.41	1.36	
Shaft Power @ Rated Speed	P_o	watts	192	192	340	333	547	533	539	717	
Voltage Constant ^{3,4}	K_b	Volts/rad/s	0.140	0.072	0.286	0.145	0.461	0.232	0.681	0.357	
Voltage Constant ^{3,4}	K_e	Volts/Krpm	14.66	7.53	29.90	15.18	48.28	24.29	71.30	37.41	
Torque Constant ⁹	$K_t(\text{sine})$	oz-in/Amp Peak	17.17	8.82	35.01	17.78	56.53	28.45	83.50	43.80	
		Nm/Amp Peak	0.120	0.062	0.245	0.124	0.396	0.199	0.584	0.307	
Resistance ³	R	Ohms	4.57	1.22	6.97	1.86	7.72	2.05	10.98	2.85	
Inductance ⁵	L	mH	15.43	4.10	32.30	8.65	42.66	11.12	61.39	16.28	
Maximum Bus Voltage	V_m	Volts DC	340	340	340	340	340	340	340	340	
Thermal Res Wind-Amb	$R_{th} w-a$	°C/watt	2.14	2.14	1.82	1.82	1.58	1.58	1.41	1.41	
Motor Constant	K_m	oz-in/ $\sqrt{\text{watt}}$	9.27	9.22	15.31	15.05	23.49	22.94	29.10	29.96	
		Nm/ $\sqrt{\text{watt}}$	0.065	0.065	0.107	0.105	0.164	0.161	0.204	0.210	
Viscous Damping	B	oz-in/Krpm	0.3	0.3	0.4	0.4	0.5	0.5	0.7	0.7	
		Nm/Krpm	1.8E-03	1.8E-03	2.5E-03	2.5E-03	3.5E-03	3.5E-03	4.9E-03	4.9E-03	
Static Friction	T_f	oz-in	0.8	0.8	1.3	1.3	2.0	2.0	2.5	2.5	
		Nm	5.3E-03	5.3E-03	8.8E-03	8.8E-03	1.4E-02	1.4E-02	1.8E-02	1.8E-02	
Motor Thermal Time Constant	τ_{th}	minutes	11.6	11.6	13.3	13.3	15.0	15.0	20.0	20.0	
Electrical Time Constant	τ_{elec}	millisecs	3.38	3.36	4.63	4.65	5.53	5.42	5.59	5.71	
Mechanical Time Const.	τ_{mch}	millisecs	1.2	1.2	0.8	0.8	0.6	0.6	0.6	0.5	
Intermittent Torque Duration ¹⁰	T_{2x}	seconds	37	37	47	47	58	58	62	62	
Peak Torque Duration ¹¹	T_{3x}	seconds	15	15	18	18	22	22	23	23	
Rotor Inertia	J	lb-in-sec ²	4.6E-05	4.6E-05	8.0E-05	8.0E-05	1.5E-04	1.5E-04	2.1E-04	2.1E-04	
		kg-m ²	5.2E-06	5.2E-06	9.0E-06	9.0E-06	1.7E-05	1.7E-05	2.4E-05	2.4E-05	
Number of Poles	Np		8	8	8	8	8	8	8	8	
Motor Weight	#	lbs	1.5	1.5	2.0	2.0	3.1	3.1	4.2	4.2	
		kg	0.7	0.7	0.9	0.9	1.4	1.4	1.9	1.9	
Winding Class			H	H	H	H	H	H	H	H	

- 1 @ 25°C ambient, 150°C winding temperature, motor connected to a 10"x10"x1/4" aluminum mounting plate.
- 2 Operation with 340 VDC bus. Maximum speed is 5000 RPM. For higher speed operation please call the factory.
- 3 Measured Line to Line, +/- 10%.
- 4 Value is measured peak of sine wave.
- 5 +/-30%, Line-to-Line, inductance bridge measurement @1Khz.
- 6 Initial winding temperature must be 60°C or less before Peak Current is Applied.
- 7 Peak of the sinusoidal current in any phase for a sinusoidally commutated motor.
- 8 Total motor torque per peak of the sinusoidal amps measured in any phase, +/-10%.
- 9 Maximum Time duration with 2 times rated current applied with initial winding temp at 60°C.
- 10 Maximum Time duration with 3 times rated current applied with initial winding temp at 60°C.

Note: These specifications are based on theoretical motor performance and are not specific to any amplifier.

Custom Designed Servo Motors For Your Specific Application. Call 1-800-358-9070 Today.

Size 23, Resolver Feedback, Performance Curves

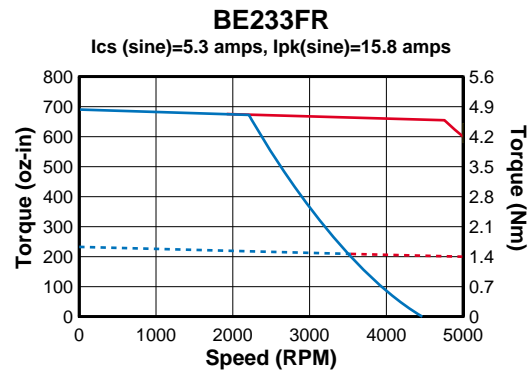
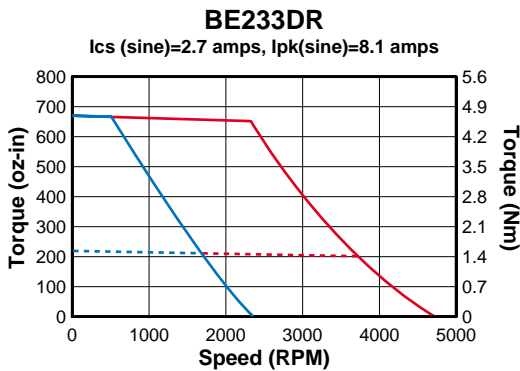
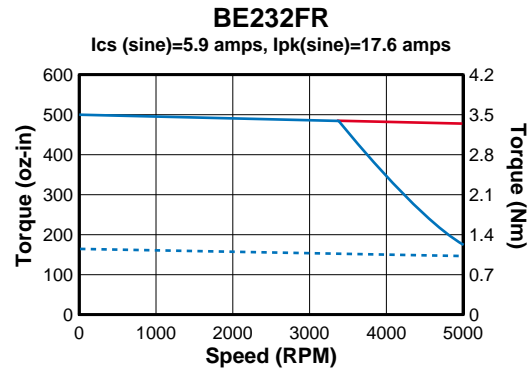
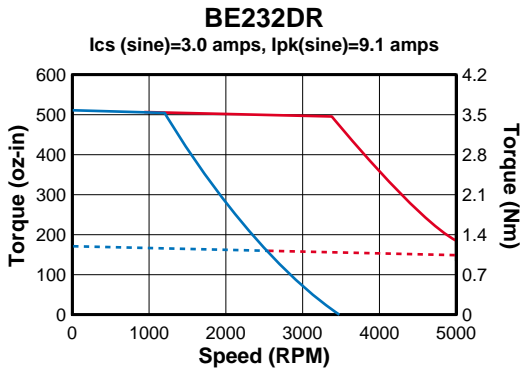
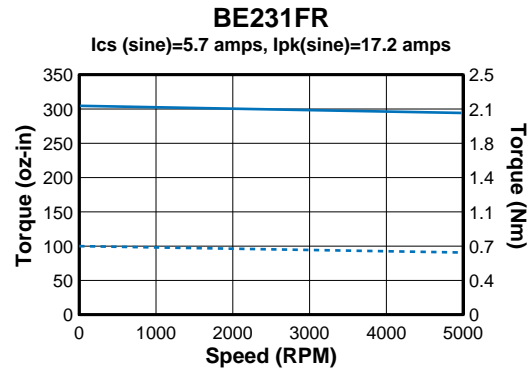
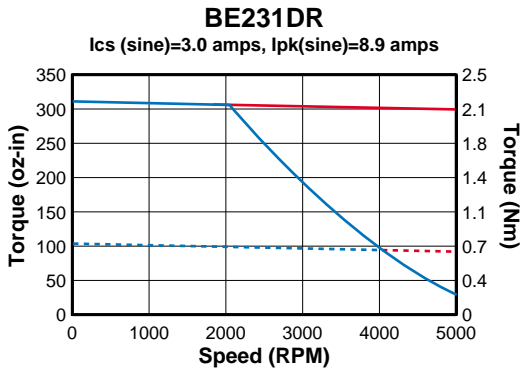
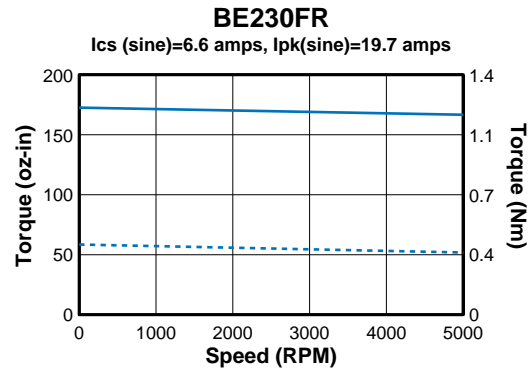
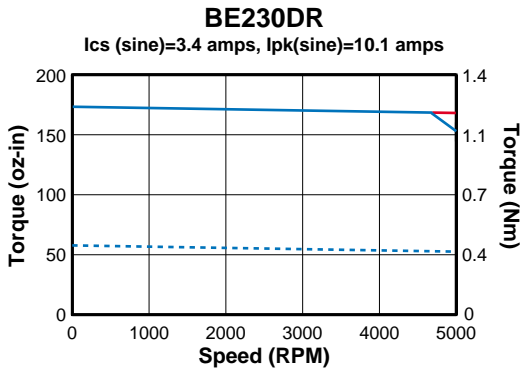

----- ——— ----- ———
 CONTINUOUS PEAK CONTINUOUS PEAK
 170 VDC 340 VDC

Size 34, Encoder Feedback, Specifications

Parameter	Symbol	Units	BE341F	BE341J	BE342H	BE342K	BE343J	BE343L	BE344J	BE344L
Stall Torque Continuous ¹	T_{cs}	lb-in	15.0	14.9	25.3	25.7	35.6	35.4	43.3	42.9
		oz-in	241	239	406	411	570	566	693	686
		Nm	1.68	1.67	2.84	2.88	3.99	3.96	4.85	4.80
Stall Current Continuous ^{1,4,8}	$I_{cs}(\text{sine})$	Amps Peak	5.1	10.4	6.9	13.5	9.9	15.8	9.1	14.3
Stall Current Continuous ^{1,7}	$I_{cs}(\text{trap})$	Amps DC	4.5	9.0	5.9	11.7	8.6	13.7	7.8	12.4
Peak Torque ⁶	T_{pk}	lb-in	45.1	44.8	76.0	77.1	106.9	106.1	129.9	128.6
		oz-in	722	717	1217	1233	1710	1697	2078	2058
		Nm	5.05	5.02	8.52	8.63	11.97	11.88	14.55	14.40
Peak Current ^{4,6,8}	$I_{pk}(\text{sine})$	Amps Peak	15.4	31.3	20.6	40.4	29.8	47.4	27.2	43.0
Peak Current ^{6,7}	$I_{pk}(\text{trap})$	Amps DC	13.4	27.1	17.8	35.0	25.8	41.0	23.5	37.3
Rated Speed ²	ω_r	rpm	4625	5000	4500	5000	4375	5000	3500	5000
Current @ Rated Speed	$I_r(\text{sine})$	Amps Peak	4.2	8.3	5.5	10.3	7.8	11.5	7.6	9.9
Current @ Rated Speed	$I_r(\text{trap})$	Amps	3.7	7.2	4.8	8.9	6.8	9.9	6.6	8.5
Torque @ Rated Speed	T_r	lb-in	11.9	11.4	20.3	19.1	27.7	24.8	35.6	28.5
		oz-in	191	182	325	305	443	397	569	456
		Nm	1.34	1.27	2.28	2.14	3.10	2.78	3.98	3.19
Shaft Power @ Rated Speed	P_o	watts	653	673	1082	1128	1434	1468	1473	1686
Voltage Constant ^{3,4}	K_b	Volts/rad/s	0.382	0.187	0.483	0.249	0.468	0.292	0.624	0.390
Voltage Constant ^{3,4}	K_e	Volts/Krpm	40.00	19.58	50.58	26.08	49.01	30.58	65.35	40.84
Torque Constant ⁹	$K_t(\text{sine})$	oz-in/Amp Peak	46.84	22.93	59.23	30.53	57.39	35.81	76.52	47.83
		Nm/Amp Peak	0.328	0.161	0.415	0.214	0.402	0.251	0.536	0.335
		oz-in/Amp DC	54.09	26.48	68.39	35.26	66.27	41.35	88.36	55.22
Torque Constant ^{3,4}	$K_t(\text{trap})$	Nm/Amp DC	0.379	0.185	0.479	0.247	0.464	0.289	0.619	0.387
Resistance ³	R	Ohms	2.59	0.63	1.70	0.44	0.96	0.38	1.23	0.49
Inductance ⁵	L	mH	35.40	7.07	21.50	5.84	15.09	6.86	20.17	7.32
Maximum Bus Voltage	V_m	Volts DC	340	340	340	340	340	340	340	340
Thermal Res Wind-Amb	$R_{th} w-a$	°C/watt	1.40	1.40	1.20	1.20	1.01	1.01	0.95	0.95
Motor Constant	K_m	oz-in/ $\sqrt{\text{watt}}$	33.61	33.36	52.45	53.15	67.64	67.07	79.67	78.89
		Nm/ $\sqrt{\text{watt}}$	0.235	0.234	0.367	0.372	0.473	0.470	0.558	0.552
Viscous Damping	B	oz-in/Krpm	1.1	1.1	1.3	1.3	1.7	1.7	2.0	2.0
		Nm/Krpm	7.6E-03	7.6E-03	9.3E-03	9.3E-03	1.2E-02	1.2E-02	1.4E-02	1.4E-02
Static Friction	T_f	oz-in	1.7	1.7	2.7	2.7	4.2	4.2	5.0	5.0
		Nm	1.2E-02	1.2E-02	1.9E-02	1.9E-02	2.9E-02	2.9E-02	3.5E-02	3.5E-02
Motor Thermal Time Constant	τ_{th}	minutes	21.6	21.6	25.0	25.0	28.3	28.3	33.3	33.3
Electrical Time Constant	τ_{elec}	milliseconds	13.67	11.22	12.65	13.27	15.72	18.05	16.40	14.94
Mechanical Time Constant	τ_{mch}	milliseconds	0.5	0.5	0.4	0.4	0.3	0.3	0.3	0.3
Intermittent Torque Duration ¹⁰	T_{2x}	seconds	65	65	78	78	116	116	127	127
Peak Torque Duration ¹¹	T_{3x}	seconds	24	24	27	27	37	37	38	38
Rotor Inertia	J	lb-in-sec ²	2.7E-04	2.7E-04	4.4E-04	4.4E-04	6.1E-04	6.1E-04	7.2E-04	7.2E-04
		kg-m ²	3.1E-05	3.1E-05	5.0E-05	5.0E-05	6.9E-05	6.9E-05	8.1E-05	8.1E-05
Number of Poles	Np		8	8	8	8	8	8	8	8
Motor Weight	#	lbs	4.8	4.8	7.1	7.1	9.4	9.4	11.7	11.7
		kg	2.2	2.2	3.2	3.2	4.3	4.3	5.3	5.3
Winding Class			H	H	H	H	H	H	H	H

1 @ 25°C ambient, 125°C winding temperature, motor connected to a 10"x10"x1/4" aluminum mounting plate.
 @40°C ambient derate phase currents and torques by 12%.
 2 Operation with 340 VDC bus. Maximum speed is 5000 RPM. For higher speed operation please call the factory.
 3 Measured Line to Line, +/- 10%.
 4 Value is measured peak of sine wave.
 5 +/-30%, Line-to-Line, inductance bridge measurement @1Khz.
 6 Initial winding temperature must be 60°C or less before peak current is applied.

7 DC current through a pair of motor phases of a trapezoidally (six state) commutated motor.
 8 Peak of the sinusoidal current in any phase for a sinusoidally commutated motor.
 9 Total motor torque per peak of the sinusoidal amps measured in any phase, +/-10%.
 10 Maximum time duration with 2 times rated current applied with initial winding temp at 60°C.
 11 Maximum time duration with 3 times rated current applied with initial winding temp at 60°C.

Note: These specifications are based on theoretical motor performance and are not specific to any amplifier.

Custom Designed Servo Motors For Your Specific Application. Call 1-800-358-9070 Today.

Size 34, Resolver Feedback, Specifications

Parameter	Symbol	Units	BE341F	BE341J	BE342H	BE342K	BE343J	BE343L	BE344J	BE344L
Stall Torque Continuous ¹	T_{cs}	lb-in	16.3	16.1	27.4	27.8	38.5	38.2	46.8	46.3
		oz-in	260	258	438	444	616	611	748	741
		Nm	1.82	1.81	3.07	3.11	4.31	4.28	5.24	5.19
Stall Current Continuous ^{1,4,8}	$I_{cs}(\text{sine})$	Amps Peak	5.6	11.3	7.4	14.6	10.7	17.1	9.8	15.5
Peak Torque ⁶	T_{pk}	lb-in	48.8	48.4	82.2	83.3	115.6	114.6	140.3	139.0
		oz-in	781	775	1315	1333	1849	1833	2245	2223
		Nm	5.46	5.42	9.21	9.33	12.94	12.83	15.72	15.56
Peak Current ^{4,6,8}	$I_{pk}(\text{sine})$	Amps Peak	16.7	33.8	22.2	43.6	32.2	51.2	29.3	46.5
Rated Speed ²	ω_r	rpm	4625	5000	4500	5000	4375	5000	3500	5000
Current @ Rated Speed	$I_r(\text{sine})$	Amps Peak	4.8	9.5	6.3	11.9	9.0	13.4	8.5	11.8
Torque @ Rated Speed	T_r	lb-in	13.8	10.0	23.8	22.1	32.7	29.3	35.6	27.3
		oz-in	220	160	381	354	523	469	570	436
		Nm	1.54	1.12	2.67	2.48	3.66	3.28	3.99	3.05
Shaft Power @ Rated Speed	P_o	watts	753	592	1268	1309	1692	1734	1476	1612
Voltage Constant ^{3,4}	K_b	Volts/rad/s	0.382	0.187	0.483	0.249	0.468	0.292	0.624	0.390
Voltage Constant ^{3,4}	K_e	Volts/Krpm	40.00	19.58	50.58	26.08	49.01	30.58	65.35	40.84
Torque Constant ⁹	$K_t(\text{sine})$	oz-in/Amp Peak	46.84	22.93	59.23	30.53	57.39	35.81	76.52	47.83
		Nm/Amp Peak	0.328	0.161	0.415	0.214	0.402	0.251	0.536	0.335
Resistance ³	R	Ohms	2.59	0.63	1.70	0.44	0.96	0.38	1.23	0.49
Inductance ⁵	L	mH	35.40	7.07	21.50	5.84	15.09	6.86	20.17	7.30
Maximum Bus Voltage	V_m	Volts DC	340	340	340	340	340	340	340	340
Thermal Res Wind-Amb	$R_{th} w-a$	°C/watt	1.40	1.40	1.20	1.20	1.01	1.01	0.95	0.95
Motor Constant	K_m	oz-in/√watt	33.61	33.36	52.45	53.15	67.64	67.07	79.67	78.89
		Nm/√watt	0.235	0.234	0.367	0.372	0.473	0.470	0.558	0.552
Viscous Damping	B	oz-in/Krpm	1.1	1.1	1.3	1.3	1.7	1.7	2.0	2.0
		Nm/Krpm	7.6E-03	7.6E-03	9.3E-03	9.3E-03	1.2E-02	1.2E-02	1.4E-02	1.4E-02
Static Friction	T_f	oz-in	1.7	1.7	2.7	2.7	4.2	4.2	5.0	5.0
		Nm	1.2E-02	1.2E-02	1.9E-02	1.9E-02	2.9E-02	2.9E-02	3.5E-02	3.5E-02
Motor Thermal Time Constant	τ_{th}	minutes	21.6	21.6	25.0	25.0	28.3	28.3	33.3	33.3
Electrical Time Constant	τ_{elec}	milliseconds	13.67	11.22	12.65	13.27	15.72	18.05	16.40	14.94
Mechanical Time Constant	τ_{mch}	milliseconds	0.6	0.6	0.4	0.4	0.3	0.3	0.3	0.3
Intermittent Torque Duration ¹⁰	T_{2x}	seconds	65	65	78	78	116	116	127	127
Peak Torque Duration ¹¹	T_{3x}	seconds	24	24	27	27	37	37	38	38
Rotor Inertia	J	lb-in-sec ²	2.9E-04	2.9E-04	4.6E-04	4.6E-04	6.3E-04	6.3E-04	8.0E-04	8.0E-04
		kg-m ²	3.3E-05	3.3E-05	5.2E-05	5.2E-05	7.1E-05	7.1E-05	9.0E-05	9.0E-05
Number of Poles	Np		8	8	8	8	8	8	8	8
Motor Weight	#	lbs	4.8	4.8	7.1	7.1	9.4	9.4	11.7	11.7
		kg	2.2	2.2	3.2	3.2	4.3	4.3	5.3	5.3
Winding Class			H	H	H	H	H	H	H	H

1 @ 25°C ambient, 150°C winding temperature, motor connected to a 10"x10"x1/4" aluminum mounting plate.
 @40C ambient derate phase currents and torques by 12%.
 2 Operation with 340 VDC bus. Maximum speed is 5000 RPM. For higher speed operation please call the factory.
 3 Measured Line to Line, +/- 10%.
 4 Value is measured peak of sine wave.
 5 +/-30%, Line-to-Line, inductance bridge measurement @1Khz.
 6 Initial winding temperature must be 60°C or less before peak current is applied.

7 Peak of the sinusoidal current in any phase for a sinusoidally commutated motor.
 8 Total motor torque per peak of the sinusoidal amps measured in any phase, +/- 10%.
 9 Maximum time duration with 2 times rated current applied with initial winding temp at 60°C.
 10 Maximum time duration with 3 times rated current applied with initial winding temp at 60°C.

Note: These specifications are based on theoretical motor performance and are not specific to any amplifier.

Custom Designed Servo Motors For Your Specific Application. Call 1-800-358-9070 Today.

Size 34, Resolver Feedback, Performance Curves

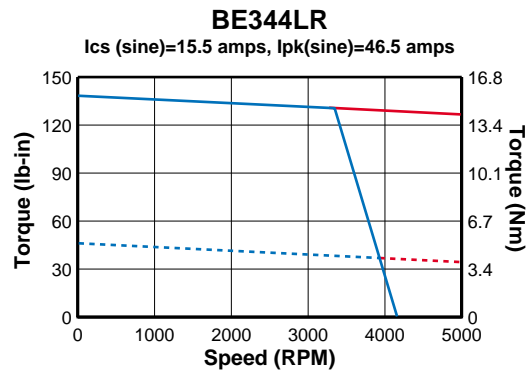
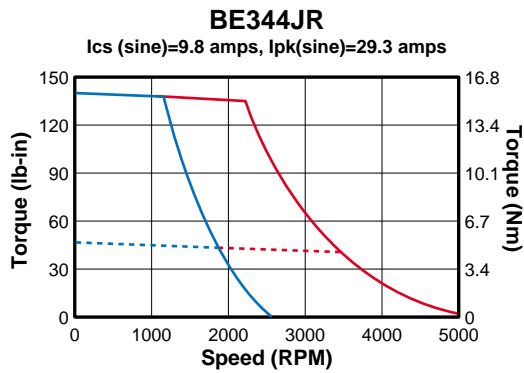
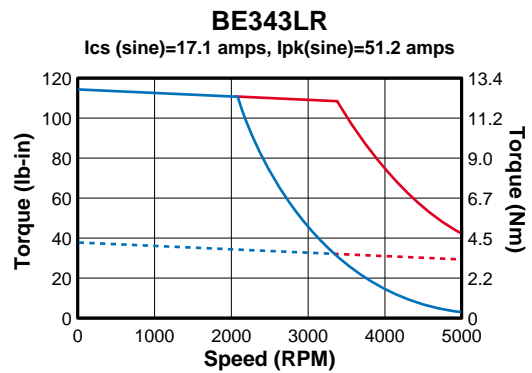
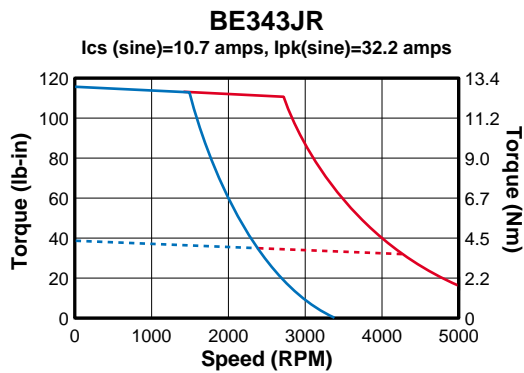
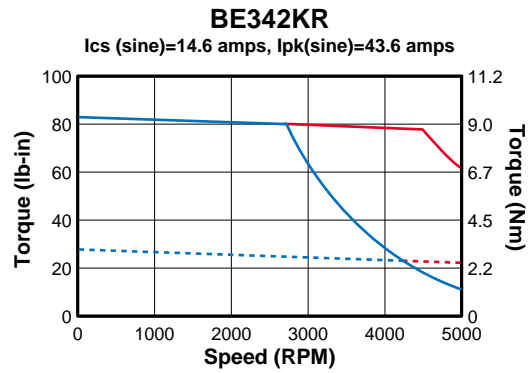
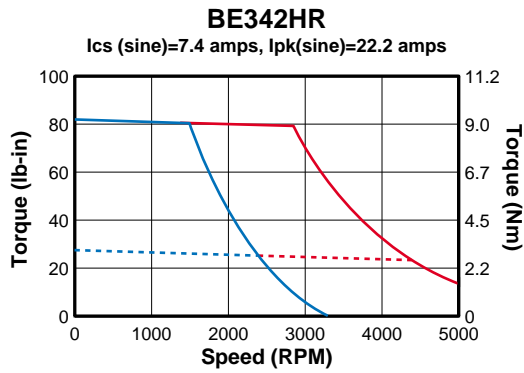
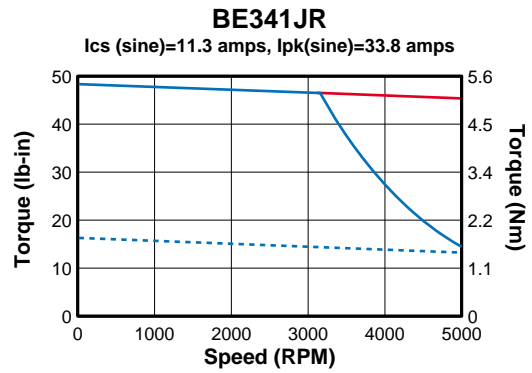
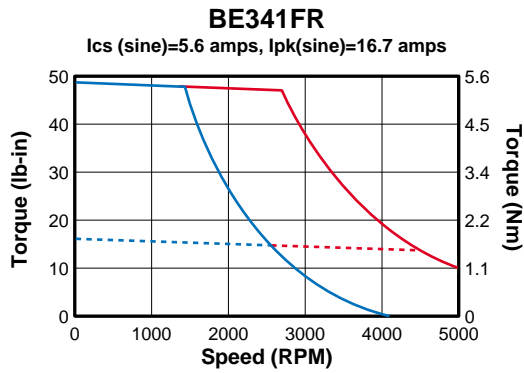

----- CONTINUOUS ——— PEAK
 170 VDC

----- CONTINUOUS ——— PEAK
 340 VDC

BE Series Dimensional Drawings

Size 16 Dimensional Drawing

Dimensions in inches (mm)

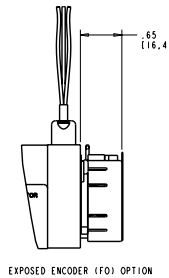
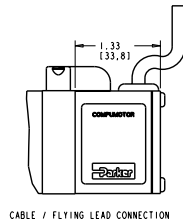
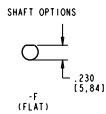
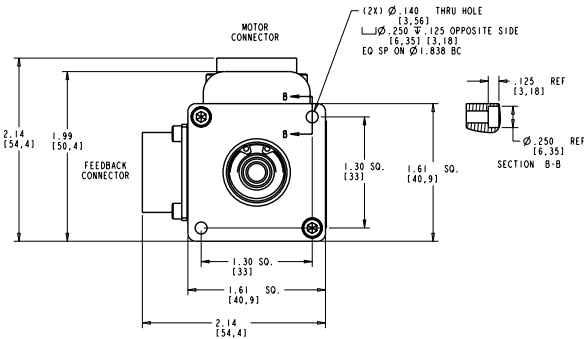

Motor Length			
Model	Standard	FO Option	Brake
BE161	3.29 (83.6)	2.02 (51.20)	2.70 (68.6)
BE162	3.79 (96.3)	2.52 (63.90)	3.20 (81.3)
BE163	4.29 (109.0)	3.02 (76.6)	3.70 (94.0)
BE164	4.79 (121.70)	3.52 (89.3)	4.20 (106.7)

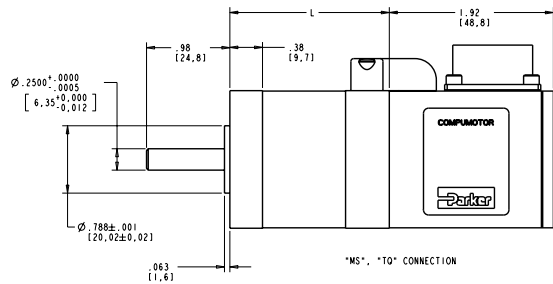

Motor Sizes	
Model	L
BE161	1.37 (34.8)
BE162	1.87 (47.5)
BE163	2.37 (60.2)
BE164	2.87 (72.9)

Size 23 Dimensional Drawing

Dimensions in inches (mm)

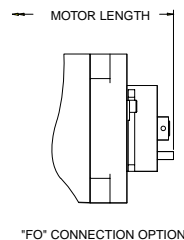
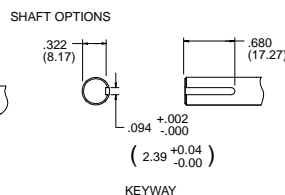
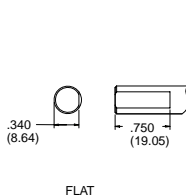
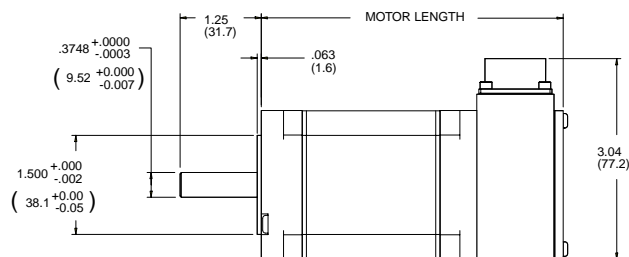
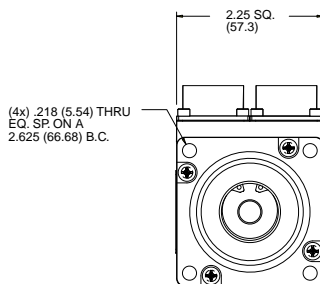

Motor Length			
Model	Standard	FO Option	Brake
BE230	3.15 (80)	2.50 (93)	4.51 (115)
BE231	3.65 (93)	3.00 (77)	5.01 (127)
BE232	4.65 (118)	4.00 (102)	6.01 (153)
BE233	5.65 (143)	5.00 (128)	7.01 (178)

Custom Designed Servo Motors For Your Specific Application. Call 1-800-358-9070 Today.

BE Series Dimensional Drawings

Size 34 Dimensional Drawing

Dimensions in inches (mm)

Motor Length

Model	Standard	FO Option	Brake
BE341	4.42 (112)	3.65 (93)	5.65 (144)
BE342	5.42 (138)	4.65 (118)	6.65 (169)
BE343	6.42 (163)	5.65 (144)	7.65 (194)
BE344	7.42 (188)	6.65 (169)	8.65 (220)

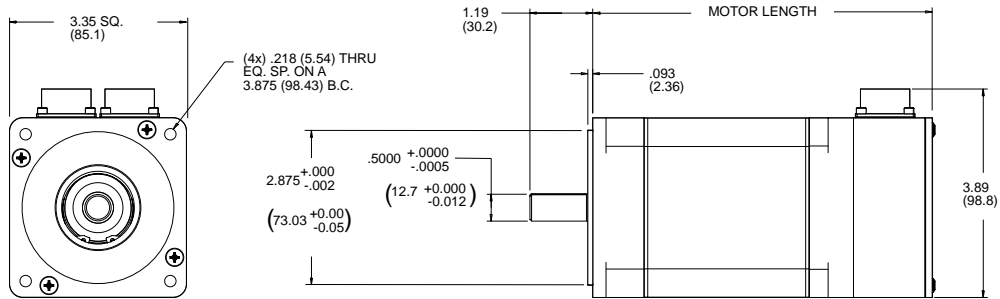

SHAFT OPTIONS

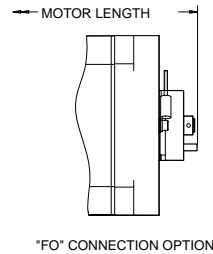
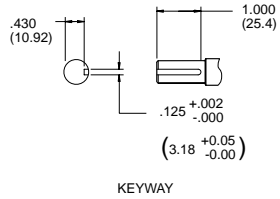
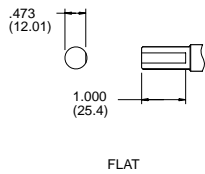

BE Series, Feedback Specifications

Resolver Schematic Diagram

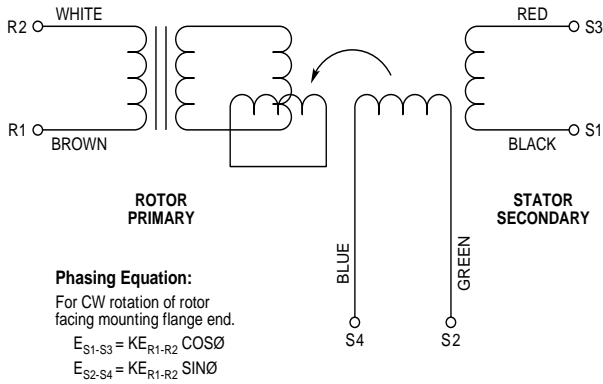

Encoder Specifications

Mechanical

Accuracy	±2 min of arc
Input power	5 VDC ±5%, 135 mA
Operating frequency	250 kHz max
Output device	26LS31
Sink/Source, nominal	20 mA
Suggested user interface	26LS32

Electrical

Resolver Specifications

Parameter	Value
Input voltage @ 7 kHz	4.25 volts
Input current, max	55 mA
Input power, nominal	0.12 watts
Impedance ZSO (@ 90°)	58+j145 ohms
Impedance ZRO	53+j72 ohms
Impedance ZRS	42+j55 ohms
Transformation ratio	0.470 ±5%
Output voltage	2.0 ±5% volts
DC rotor resistance	23 ±10% ohms
DC stator resistance	19 ±10% ohms
Sensitivity	35 mV/degree
Max error from EZ	±10 minutes
Phase shift, open circuit	5° leading, ±3"
Null voltage, total	20 mV rms
Impedance ZSS	50+j128 ohms
Inertia	Incl. with motor spec.

Hall-Effect Specifications

Electrical

Input power	5 VDC ±5%, 80 mA
Output device	LM339
open collector	
Maximum pull up	12 VDC
Sink	16 mA

Electrically Released Brakes

Brakes

Size 23

Size 34

	Size 23	Size 34
Static rated torque	10 in-lb	40 in-lb
Coil voltage	24 VDC	24 VDC
Coil current	0.38 amps	0.7 amps
Weight	0.7 lbs	1.2 lbs
Inertia	1.87 E-05 lb-in-sec ²	1.14E-04 lb-in-sec ²
Engage/Disengage	10/20 msec	20/40 msec

Commutation Chart

Clockwise rotation as viewed from front shaft.

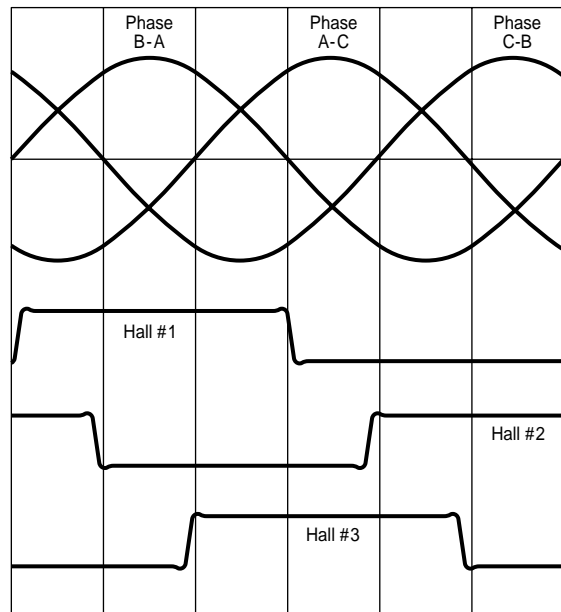

Custom Designed Servo Motors For Your Specific Application. Call 1-800-358-9070 Today.

Wiring and Cable Specifications

Flying Leads, Cabled and "MS" Connection Options

The **"FO" connection** option for the BE Series motors features 18" leads extending from the motor body. This option features a plastic encoder cover and no connector housing. Wire color codes are the same as listed below for "MS" wired BE Series motors. The "FO" option is only available on motors with encoder feedback.

The **"FL" connection** option for the BE Series motors features 18" leads extending from the motor body. This option features an extruded aluminum housing. Wire color codes are the same as listed below for "MS" wired BE Series motors. The "FL" option is only available on motors with encoder feedback.

The **"10" connection** option for the BE Series motors consists of 10 feet of hard-wired cable extending from the motor body. These cables terminate in flying leads. Wire color codes are the same as listed below for the "MS" connection option. The "10" option is only available on motors with encoder feedback.

The **"MS" connection** option for the BE Series motors provides quick disconnect, bayonet style connectors attached to the motor body. Mating cables are specified and ordered separately. With the "MS" connection option, the motor phase wires are in one connector, and the hall, encoder, temperature switch, and brake wires are in the other connector. This option works well when using an amplifier with a built-in controller, or when all cables enter into a cabinet or enclosure and then are wired into a terminal strip. When specifying the "R" (resolver) feedback option, the motor phase wires reside in one connector, the resolver signal, temperature switch, and brake wires in the other.

Motor Connection

Designation	Pin Number MS14-12 ¹	Wire Color	
		"MS"/"RS" Cables	"GS/GB" Cables
Phase A	J	Red/Yellow	Black 1
Phase B	K	White/Yellow	Black 2
Phase C	L	Black/Yellow	Black 3
Ground	M	Green/Yellow	Green/Yellow
Shield	N.C.	Clear	N.C.

Encoder/Hall Feedback Connection

Designation	Pin Number MS14-18	Wire Color
Encoder +5	H	Red
Encoder Ground	G	Black
CH A +	A	White
CH A -	B	Yellow
CH B +	C	Green
CH B -	D	Blue
Index +	E	Orange
Index -	F	Brown
Hall Ground	K	White/Green
Hall +5	M	White/Blue
Hall 1	T	White/Brown
Hall 2	U	White/Orange
Hall 3	P	White/Violet
Brake ¹	R	Red/Blue
Brake ¹	S	Red/Blue
Temp	L	Orange/Yellow
Temp	N	Orange/Yellow
Shield	N.C.	Clear

¹ Brake will operate regardless of polarity of connection

Resolver Feedback Connection

Designation	Pin Number MS14-18	Wire Color
S1, COS +	E	Black
S2, SIN +	L	Green
S3, COS -	J	Red
S4, SIN -	G	Blue
R1, EXC +	C	Brown
R2, EXC -	U	White
Temp	R	Orange/Yellow or Yellow
Temp	N	Orange/Yellow or Yellow
Brake ²	S	Red/Blue
Brake ²	T	Red/Blue
Shield	N.C.	Clear

Wiring and Cable Specifications (continued)

“TQ” Connection Option

The **“TQ” Connection** option for the BE series motors provides quick disconnect, bayonet style connectors attached to the motor body. Mating cables are specified and ordered separately. The “TQ” connection option joins the motor phase wires, temperature switch, and hall effect signals in one

connector. The second connector has only encoder signals. This connection option applies well in applications where the hall and motor phase wires connect directly to an amplifier, while the encoder signals connect directly to a controller.

Motor/Hall Connection

Designation	Pin Number MS14-12	Wire Color
Phase A	J	Red/Yellow
Phase B	K	White/Yellow
Phase C	L	Black/Yellow
Ground	M	Green/Yellow
Temp	G	Orange/Yellow or Yellow
Temp	H	Orange/Yellow or Yellow
Shield	N.C.	Clear
Hall Ground	F	White/Green
Hall +5	B	White/Blue
Hall 1	C	White/Brown
Hall 2	D	White/Orange
Hall 3	E	White/Violet

Encoder Feedback Connection

Designation	Pin Number MS14-18	Wire Color
Encoder +5	H	Red
Encoder Ground	G	Black
CH A +	A	White
CH A -	B	Yellow
CH B +	C	Green
CH B -	D	Blue
Index +	E	Orange
Index -	F	Brown
Brake ¹	R	Red/Blue
Brake ¹	S	Red/Blue

¹ Brake will operate regardless of polarity of connection

Custom Designed Servo Motors For Your Specific Application. Call 1-800-358-9070 Today.