

MOTOR DATA @ 230 VAC (SINE)

MOTOR PARAMETERS	UNITS	VALUE
HORSEPOWER	HP	.51
KILOWATTS	KW	.38
MAX. OPERATING SPEED	N MAX RPM	5000
SPEED @ RATED TORQUE	N RATED RPM	4000
* CONTINUOUS RATED TORQUE @ 4000 RPM	IN-LBS[Nm]	8.0[.90]
* CONTINUOUS STALL TORQUE	IN-LBS[Nm]	12.0[1.36]
CONTINUOUS LINE CURRENT	AMPS	2.1
PEAK CURRENT	IN-LBS[Nm]	36.0[4.10]
PEAK CURRENT	AMPS	6.4
MAX. THEORETICAL ACCEL. TORQUE SENSITIVITY	RAD/SEC ²	84,309
BACK EMF (LINE TO LINE)	K ϵ [IN-LBS/AMP][Nm/AMP]	5.9[.67]
D.C. RESISTANCE (P-P)	Vrms/Krpm	37.0
INDUCTANCE (P-P)	OHMS	11.1
ROTOR INERTIA	MILLIHENRIES	24.0
STATIC FRICTION	Jm [IN-LBS-SEC ²][$Kg-M^2$]	.000427[.0000482]
	Tf [IN-LBS[Nm]	.3[0.03]

*25°C AMBIENT WITH A MAXIMUM CASE TEMPERATURE OF 100°C ON MOTOR. MOTOR MOUNTED ON A 10" X 10" X 1/4" ALUMINUM HEATSINK. THERMOSTAT IN STATOR WINDINGS WILL OPEN IF WINDING TEMPERATURE EXCEEDS 155°C. THIS ALLOWS FOR AN APPROXIMATE +10% HEADROOM IN THE CONTINUOUS TORQUE RATING BEFORE THERMOSTAT OPENS.

MECHANICAL NOTES:

1. AXIAL LOAD: 25 LBS MAX
2. RADIAL LOAD: 40 LBS MAX @ 1" FROM FACE
3. MOTOR SEALED TO IP65.
4. MOTOR WEIGHT: - LBS. [- Kg]
5. MOTOR FINISH: BLACK EPOXY
6. MOTOR OUTPUT SHAFT: STAINLESS STEEL
7. INCHES (MILLIMETERS)

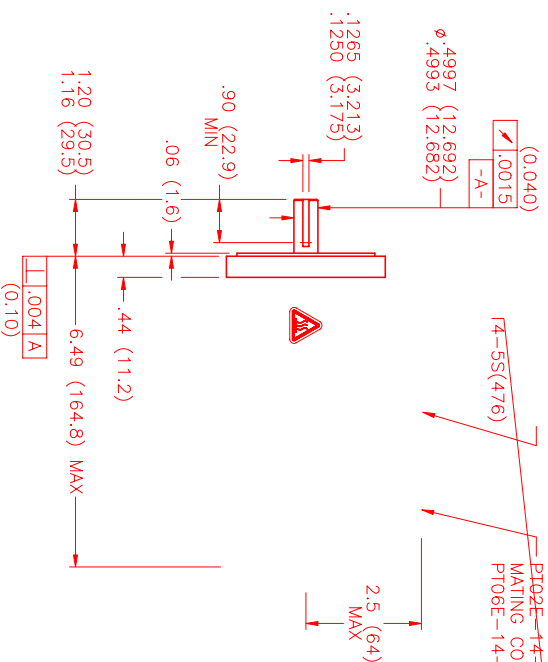
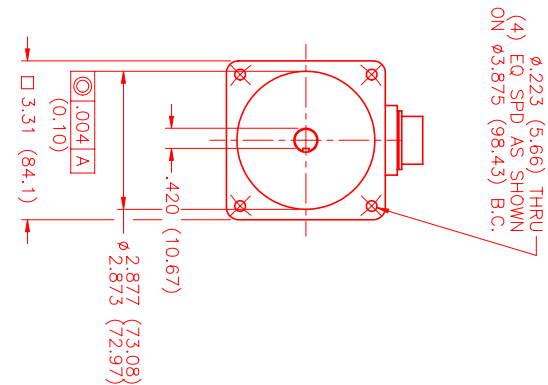

CONNECTION CHART
MOTOR CONNECTOR:
PT02E-14-5P(027)
(270-00026)

PIN	WIRE FUNCTION	WIRE COLOR
A	ΦR	RED
B	ΦS	BLACK
C	ΦT	BLUE
D	PE GND	GRN/YEL
E	-	-

ENCODER/THERM CONNECTOR:
PT02E-14-18P(027)
(270-00024)

PIN	WIRE FUNCTION	WIRE COLOR
T	GROUND	BLACK
K	+5VDC	RED
B	CH A	BLUE
C	CH A\	BLUE/BLK
N	CH B	GREEN
P	CH B\	GRN/BLK
M	CH Z	YELLOW
U	CH Z\	YEL/BLK
E	CH U	BROWN
R	CH U\	BRN/BLK
F	CH V	GRAY
S	CH V\	GRAY/BLK
G	CH W	WHITE
H	CH W\	WHT/BLK
A	THERM	BLACK
L	THERM	BLACK
J	GND	GRN/YEL

PT02E-14-18P(027)
MATING CONNECTOR:
PT06E-14-18S(476)

MOTOR ROTATION CCW (COUNTER CLOCKWISE)
(LOOKING AT THE FACE OF THE MOTOR)

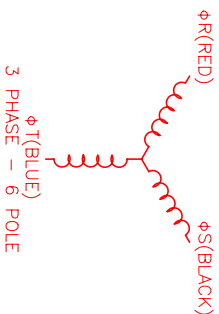
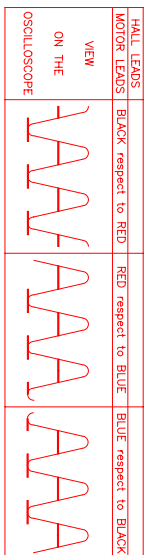

NO.	PART NUMBER	DESCRIPTION	QTY.
1	MPM890ASG6J1N	MOTOR	1

REV.	DESCRIPTION	DATE	APP.
PRELIMINARY		9/24/01	LIN

DATE: 9/24/01	TITLE: "A"/SINE/230/ENG/T2/CONN
DESIGNED BY: LIN	DRAWN BY: MPM890ASG6J1N
CHECKED BY:	SCALE: 1/2=1

MTS MTS Systems Corporation
Automation Division