

Ⓜ MOTOR DATA @ 230 VAC (TRAP)

MOTOR PARAMETERS	UNITS	VALUE
HORSEPOWER	HP	0.91
KILOWATTS	KW	0.68
MAX. OPERATING SPEED	N. MAX RPM	6300
SPEED @ RATED TORQUE	N RATED RPM	4500
* CONTINUOUS RATED TORQUE @ 4000 RPM	IN-LBS[Nm]	12.8[1.47]
* CONTINUOUS STALL TORQUE	IN-LBS[Nm]	15.0[1.69]
CONTINUOUS LINE CURRENT	AMPS	5.1
PEAK TORQUE	IN-LBS[Nm]	45.0[5.1]
PEAK CURRENT	AMPS	15.0
MAX. THEORETICAL ACCEL.	RAD/SEC <sup>2</sup>	120,000
TORQUE SENSITIVITY	Kt IN-LBS/AMP[Nm/AMP]	2.96[0.334]
BACK EMF (LINE TO LINE)	Vrms/Krpm	26.3
D.C. RESISTANCE (P-P)	OHMS	2.2
INDUCTANCE (P-P)	MILLIHENRIES	4.9
ROTOR INERTIA W/BRAKE	Jm IN-LBS-SEC <sup>2</sup> [Kg-M <sup>2</sup> ]	0.00045[0.000051]
STATIC FRICTION	Tf IN-LBS[Nm]	1.0[0.11]

\*25°C AMBIENT WITH A MAXIMUM CASE TEMPERATURE OF 85°C ON MOTOR. MOTOR MOUNTED ON A 1/2" X 1/2" X 1/2" ALUMINUM HEATSINK. THERMOSTAT IN STATOR WINDINGS WILL OPEN IF WINDING TEMPERATURE EXCEEDS 155°C. THIS ALLOWS FOR AN APPROXIMATE +10% HEADROOM IN THE CONTINUOUS TORQUE RATING BEFORE THERMOSTAT OPENS.

MECHANICAL NOTES:

- AXIAL LOAD: 20 LBS. MAX
- RADIAL LOAD: 35 LBS. MAX @ 1" FROM FACE
- MOTOR SEALED TO IP65.
- MOTOR WEIGHT: 6.2 LBS. [ 2.8 Kg]
- MOTOR FINISH: BLACK EPOXY
- MOTOR OUTPUT SHAFT: STAINLESS STEEL
- MILLIMETERS (INCHES)
- THIS MOTOR'S OUTPUT KEY IS A PRESS FIT.

FAILSAFE BRAKE:

MIN. HOLDING TORQUE: 24 IN-LBS  
INPUT VOLTAGE: 24 VOLTS

CONNECTION CHART  
MOTOR/THERM/RES/BRK CONNECTOR:  
PT02E-14-18P(027)  
(270-00024)

MTR/RES/THERM	WIRE LEADS	
PIN	FUNCTION	WIRE COLOR
A	ΦR	RED
B	ΦS	BLACK
C	ΦT	BLUE
D	PE GND	GRN/YEL
U	THERM	BLACK
N	THERM	BLACK
H	SIN	YELLOW
G	COS GND	BLACK
S	COS	RED
F	SIN GND	BLUE
R	REF GND	YEL/WHI
E	REF	RED/WHI
J	RES SHLD	GRN/YEL
K	BRK (+)	□ DIODE
L	BRK (-)	□ IN4007
M	BRK SHLD	-
P	-	-
T	-	-

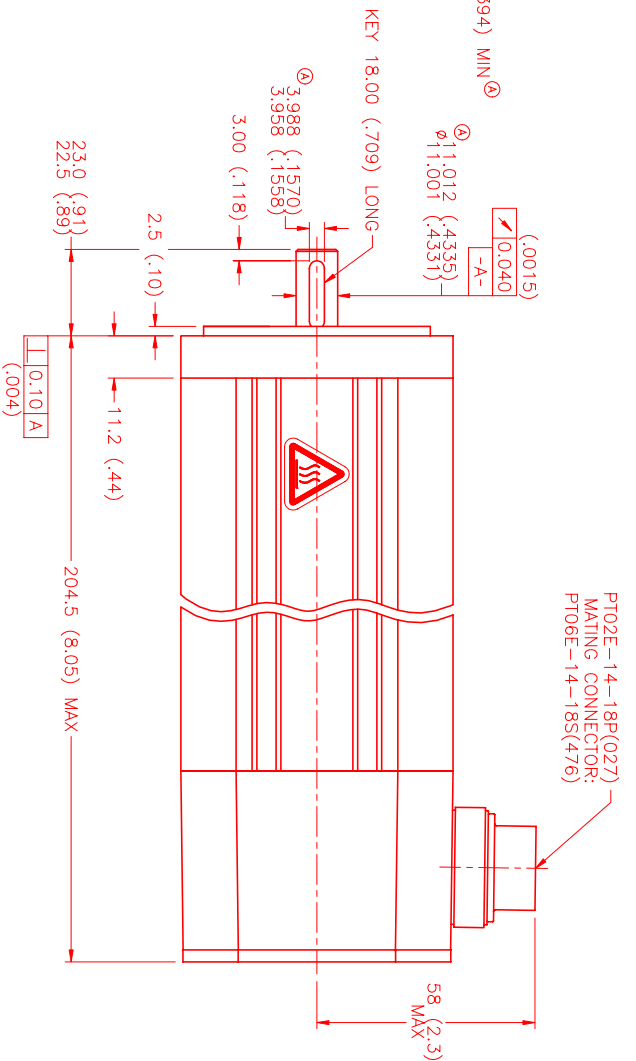
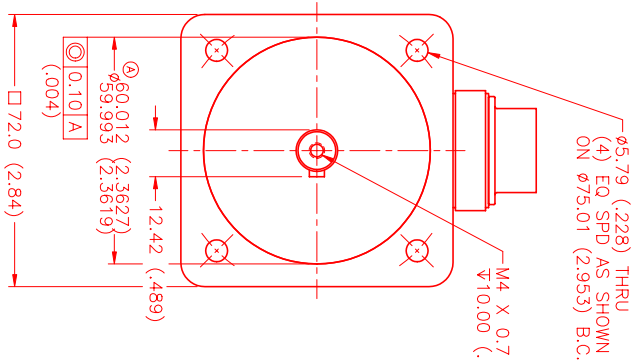

PT02E-14-18P(027)  
MATING CONNECTOR:  
PT06E-14-18S(476)

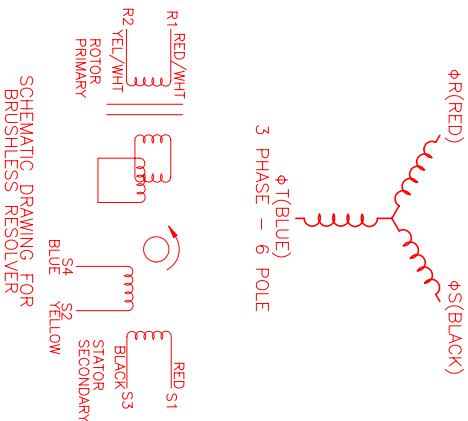

REV.	DESCRIPTION	DATE	APP'D.
A	E.C.O. - 558	2/2/00	AJS

REVISIONS

REV.	DESCRIPTION	DATE	APP'D.
A	E.C.O. - 558	2/2/00	AJS

NO.	PART NUMBER	DESCRIPTION	QTY.
1	PT02E-14-18P(027)	MOTOR/THERM/RES/BRK CONNECTOR	1

NO.	PART NUMBER	DESCRIPTION	QTY.
1	PT02E-14-18P(027)	MOTOR/THERM/RES/BRK CONNECTOR	1

NO.	PART NUMBER	DESCRIPTION	QTY.
1	PT02E-14-18P(027)	MOTOR/THERM/RES/BRK CONNECTOR	1

NO.	PART NUMBER	DESCRIPTION	QTY.
1	PT02E-14-18P(027)	MOTOR/THERM/RES/BRK CONNECTOR	1

NO.	PART NUMBER	DESCRIPTION	QTY.
1	PT02E-14-18P(027)	MOTOR/THERM/RES/BRK CONNECTOR	1

NO.	PART NUMBER	DESCRIPTION	QTY.
1	PT02E-14-18P(027)	MOTOR/THERM/RES/BRK CONNECTOR	1

NO.	PART NUMBER	DESCRIPTION	QTY.
1	PT02E-14-18P(027)	MOTOR/THERM/RES/BRK CONNECTOR	1

NO.	PART NUMBER	DESCRIPTION	QTY.
1	PT02E-14-18P(027)	MOTOR/THERM/RES/BRK CONNECTOR	1

NO.	PART NUMBER	DESCRIPTION	QTY.
1	PT02E-14-18P(027)	MOTOR/THERM/RES/BRK CONNECTOR	1

NO.	PART NUMBER	DESCRIPTION	QTY.
1	PT02E-14-18P(027)	MOTOR/THERM/RES/BRK CONNECTOR	1

NO.	PART NUMBER	DESCRIPTION	QTY.
1	PT02E-14-18P(027)	MOTOR/THERM/RES/BRK CONNECTOR	1

NO.	PART NUMBER	DESCRIPTION	QTY.
1	PT02E-14-18P(027)	MOTOR/THERM/RES/BRK CONNECTOR	1

NO.	PART NUMBER	DESCRIPTION	QTY.
1	PT02E-14-18P(027)	MOTOR/THERM/RES/BRK CONNECTOR	1

NO.	PART NUMBER	DESCRIPTION	QTY.
1	PT02E-14-18P(027)	MOTOR/THERM/RES/BRK CONNECTOR	1

NO.	PART NUMBER	DESCRIPTION	QTY.
1	PT02E-14-18P(027)	MOTOR/THERM/RES/BRK CONNECTOR	1

NO.	PART NUMBER	DESCRIPTION	QTY.
1	PT02E-14-18P(027)	MOTOR/THERM/RES/BRK CONNECTOR	1

NO.	PART NUMBER	DESCRIPTION	QTY.
1	PT02E-14-18P(027)	MOTOR/THERM/RES/BRK CONNECTOR	1

NO.	PART NUMBER	DESCRIPTION	QTY.
1	PT02E-14-18P(027)	MOTOR/THERM/RES/BRK CONNECTOR	1

NO.	PART NUMBER	DESCRIPTION	QTY.
1	PT02E-14-18P(027)	MOTOR/THERM/RES/BRK CONNECTOR	1

NO.	PART NUMBER	DESCRIPTION	QTY.
1	PT02E-14-18P(027)	MOTOR/THERM/RES/BRK CONNECTOR	1

NO.	PART NUMBER	DESCRIPTION	QTY.
1	PT02E-14-18P(027)	MOTOR/THERM/RES/BRK CONNECTOR	1

NO.	PART NUMBER	DESCRIPTION	QTY.
1	PT02E-14-18P(027)	MOTOR/THERM/RES/BRK CONNECTOR	1

NO.	PART NUMBER	DESCRIPTION	QTY.
1	PT02E-14-18P(027)	MOTOR/THERM/RES/BRK CONNECTOR	1

NO.	PART NUMBER	DESCRIPTION	QTY.
1	PT02E-14-18P(027)	MOTOR/THERM/RES/BRK CONNECTOR	1

NO.	PART NUMBER	DESCRIPTION	QTY.
1	PT02E-14-18P(027)	MOTOR/THERM/RES/BRK CONNECTOR	1

NO.	PART NUMBER	DESCRIPTION	QTY.
1	PT02E-14-18P(027)	MOTOR/THERM/RES/BRK CONNECTOR	1

NO.	PART NUMBER	DESCRIPTION	QTY.
1	PT02E-14-18P(027)	MOTOR/THERM/RES/BRK CONNECTOR	1

NO.	PART NUMBER	DESCRIPTION	QTY.
1	PT02E-14-18P(027)	MOTOR/THERM/RES/BRK CONNECTOR	1

NO.	PART NUMBER	DESCRIPTION	QTY.
1	PT02E-14-18P(027)	MOTOR/THERM/RES/BRK CONNECTOR	1

NO.	PART NUMBER	DESCRIPTION	QTY.
1	PT02E-14-18P(027)	MOTOR/THERM/RES/BRK CONNECTOR	1

NO.	PART NUMBER	DESCRIPTION	QTY.
1	PT02E-14-18P(027)	MOTOR/THERM/RES/BRK CONNECTOR	1

NO.	PART NUMBER	DESCRIPTION	QTY.
1	PT02E-14-18P(027)	MOTOR/THERM/RES/BRK CONNECTOR	1

NO.	PART NUMBER	DESCRIPTION	QTY.
1	PT02E-14-18P(027)	MOTOR/THERM/RES/BRK CONNECTOR	1

NO.	PART NUMBER	DESCRIPTION	QTY.
1	PT02E-14-18P(027)	MOTOR/THERM/RES/BRK CONNECTOR	1

NO.	PART NUMBER	DESCRIPTION	QTY.
1	PT02E-14-18P(027)	MOTOR/THERM/RES/BRK CONNECTOR	1

NO.	PART NUMBER	DESCRIPTION	QTY.
1	PT02E-14-18P(027)	MOTOR/THERM/RES/BRK CONNECTOR	1

NO.	PART NUMBER	DESCRIPTION	QTY.
1	PT02E-14-18P(027)	MOTOR/THERM/RES/BRK CONNECTOR	1

NO.	PART NUMBER	DESCRIPTION	QTY.
1	PT02E-14-18P(027)	MOTOR/THERM/RES/BRK CONNECTOR	1

NO.	PART NUMBER	DESCRIPTION	QTY.
1	PT02E-14-18P(027)	MOTOR/THERM/RES/BRK CONNECTOR	1

NO.	PART NUMBER	DESCRIPTION	QTY.
1	PT02E-14-18P(027)	MOTOR/THERM/RES/BRK CONNECTOR	1

NO.	PART NUMBER	DESCRIPTION	QTY.
1	PT02E-14-18P(027)	MOTOR/THERM/RES/BRK CONNECTOR	1

NO.	PART NUMBER	DESCRIPTION	QTY.
1	PT02E-14-18P(027)	MOTOR/THERM/RES/BRK CONNECTOR	1

NO.	PART NUMBER	DESCRIPTION	QTY.
1	PT02E-14-18P(027)	MOTOR/THERM/RES/BRK CONNECTOR	1

NO.	PART NUMBER	DESCRIPTION	QTY.
1	PT02E-14-18P(027)	MOTOR/THERM/RES/BRK CONNECTOR	1

NO.	PART NUMBER	DESCRIPTION	QTY.
1	PT02E-14-18P(027)	MOTOR/THERM/RES/BRK CONNECTOR	1

NO.	PART NUMBER	DESCRIPTION	QTY.
1	PT02E-14-18P(027)	MOTOR/THERM/RES/BRK CONNECTOR	1

NO.	PART NUMBER	DESCRIPTION	QTY.
1	PT02E-14-18P(027)	MOTOR/THERM/RES/BRK CONNECTOR	1

NO.	PART NUMBER	DESCRIPTION	QTY.
1	PT02E-14-18P(027)	MOTOR/THERM/RES/BRK CONNECTOR	1

NO.	PART NUMBER	DESCRIPTION	QTY.
1	PT02E-14-18P(027)	MOTOR/THERM/RES/BRK CONNECTOR	1

NO.	PART NUMBER	DESCRIPTION	QTY.
1	PT02E-14-18P(027)	MOTOR/THERM/RES/BRK CONNECTOR	1

NO.	PART NUMBER	DESCRIPTION	QTY.
1	PT02E-14-18P(027)	MOTOR/THERM/RES/BRK CONNECTOR	1

NO.	PART NUMBER	DESCRIPTION	QTY.
1	PT02E-14-18P(027)	MOTOR/THERM/RES/BRK CONNECTOR	1

NO.	PART NUMBER	DESCRIPTION	QTY.
1	PT02E-14-18P(027)	MOTOR/THERM/RES/BRK CONNECTOR	1

NO.	PART NUMBER	DESCRIPTION	QTY.
1	PT02E-14-18P(027)	MOTOR/THERM/RES/BRK CONNECTOR	1

NO.	PART NUMBER	DESCRIPTION	QTY.
1	PT02E-14-18P(027)	MOTOR/THERM/RES/BRK CONNECTOR	1

NO.	PART NUMBER	DESCRIPTION	QTY.
1	PT02E-14-18P(027)	MOTOR/THERM/RES/BRK CONNECTOR	1

NO.	PART NUMBER	DESCRIPTION	QTY.
1	PT02E-14-18P(027)	MOTOR/THERM/RES/BRK CONNECTOR	1

NO.	PART NUMBER	DESCRIPTION	QTY.
1	PT02E-14-18P(027)	MOTOR/THERM/RES/BRK CONNECTOR	1

NO.	PART NUMBER	DESCRIPTION	QTY.
1	PT02E-14-18P(027)	MOTOR/THERM/RES/BRK CONNECTOR	1

NO.	PART NUMBER	DESCRIPTION	QTY.
1	PT02E-14-18P(027)	MOTOR/THERM/RES/BRK CONNECTOR	1

NO.	PART NUMBER	DESCRIPTION	QTY.
1	PT02E-14-18P(027)	MOTOR/THERM/RES/BRK CONNECTOR	1

NO.	PART NUMBER	DESCRIPTION	QTY.
1	PT02E-14-18P(027)	MOTOR/THERM/RES/BRK CONNECTOR	1

NO.	PART NUMBER	DESCRIPTION	QTY.
1	PT02E-14-18P(027)	MOTOR/THERM/RES/BRK CONNECTOR	1

NO.	PART NUMBER	DESCRIPTION	QTY.
-----	-------------	-------------	------