

MOTOR DATA @ 230 VAC (TRAP)

MOTOR PARAMETERS	UNITS	VALUE
HORSEPOWER	HP RATED	10.5
KILOWATTS	KW RATED	7.8
MAX. OPERATING SPEED	N. MAX RPM	1500
SPEED @ RATED TORQUE	N RATED RPM	1200
* CONTINUOUS RATED TORQUE @ 1200 RPM	IN-LBS[Nm]	550.0 [61.8]
* CONTINUOUS STALL TORQUE	IN-LBS[Nm]	640.0 [71.9]
CONTINUOUS LINE CURRENT	AMPS	36.0
PEAK TORQUE	IN-LBS[Nm]	1920.0 [215.0]
PEAK CURRENT	AMPS	107.0
MAX. THEORETICAL ACCEL.	RAD/SEC ²	26,891
TORQUE SENSITIVITY	Kt [IN-LBS/AMP] [Nm/AMP]	17.6 [2.0]
BACK EMF (LINE TO LINE)	Vrms/Krpm	158.0
D.C. RESISTANCE (P-P)	OHMS	.44
INDUCTANCE (P-P)	MILLIHENRIES	6.8
ROTOR INERTIA	Jm [IN-LBS-SEC ²] [Kg-M ²]	.0714 [0.00807]
STATIC FRICTION	Tf [IN-LBS] [Nm]	9.8 [1.1]

*25°C AMBIENT WITH A MAXIMUM CASE TEMPERATURE OF 100°C ON MOTOR. MOTOR MOUNTED ON A 14" X 14" X 3/4" ALUMINUM HEATSINK. THERMOSTAT IN STATOR WINDINGS WILL OPEN IF WINDING TEMPERATURE EXCEEDS 155°C. THIS ALLOWS FOR AN APPROXIMATE +10% HEADROOM IN THE CONTINUOUS TORQUE RATING BEFORE THERMOSTAT OPENS.

- MECHANICAL NOTES:**
- AXIAL LOAD: 100 LBS MAX
 - RADIAL LOAD: 250 LBS MAX @ 1" FROM FACE
 - MOTOR SEALED TO IP65
 - MOTOR WEIGHT: 100 LBS [45.4 kg]
 - MOTOR FINISH: BLACK EPOXY
 - MILLIMETERS (INCHES)

ENCODER: (290-00052)
OH48-2000P6-L6-5V

CONNECTION CHART

MOTOR CONNECTOR:
SG3102E-32-17P(027)
(270-00066)

MOTOR WIRE LEADS	WIRE FUNCTION	WIRE COLOR
A	ΦR	RED
B	ΦS	BLACK
C	ΦT	BLUE
D	PE GND	GRN/YEL

ENCODER/THERM CONNECTOR:

PT02E-14-18P(027)
(270-00024)

ENC/THERM WIRE LEADS	WIRE FUNCTION	WIRE COLOR
T	GROUND	BLACK
K	+5VDC	RED
B	CH A	BLUE
N	CH B	GREEN
P	CH B'	GRN/BLK
M	CH Z	YELLOW
U	CH Z'	YEL/BLK
E	CH U	BROWN
R	CH U'	BRN/BLK
F	CH V	GRAY
S	CH V'	GRAY/BLK
G	CH W	WHITE
H	CH W'	WHT/BLK
D	GND/CABLE SHLD	SHLD
A	THERM	BLACK
L	THERM	BLACK
J	GND	GRN/YEL

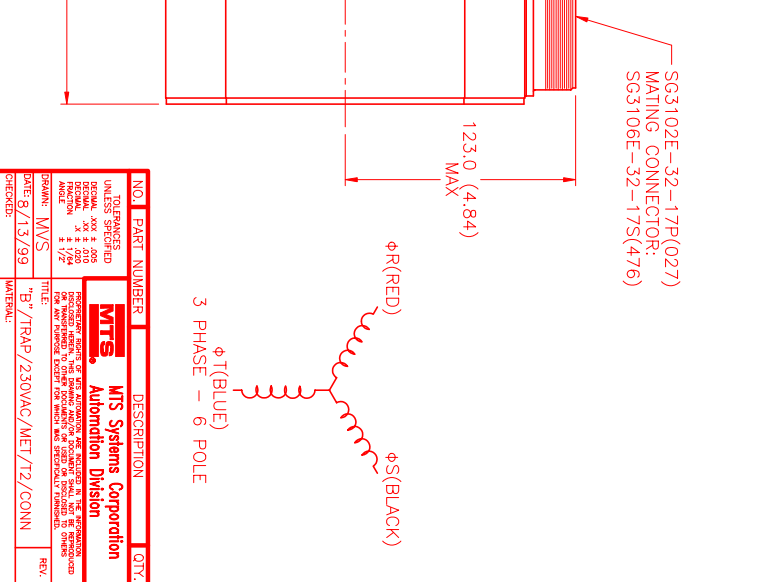
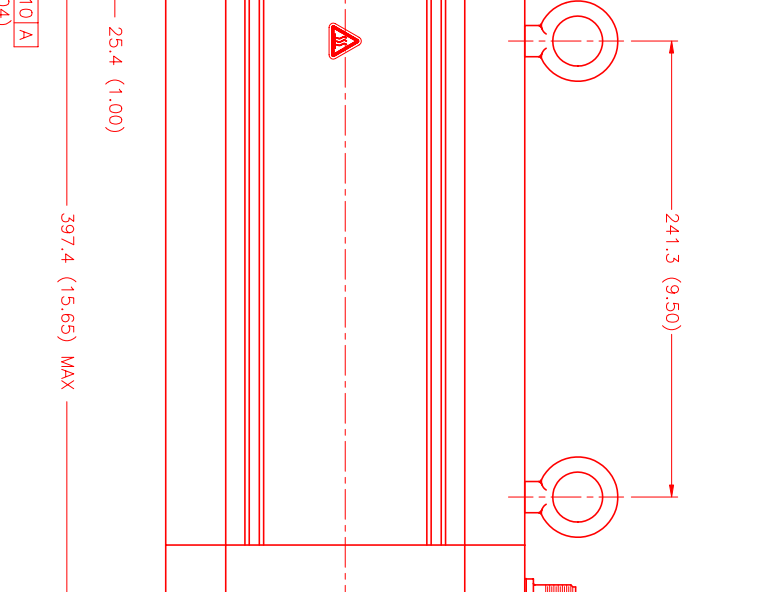
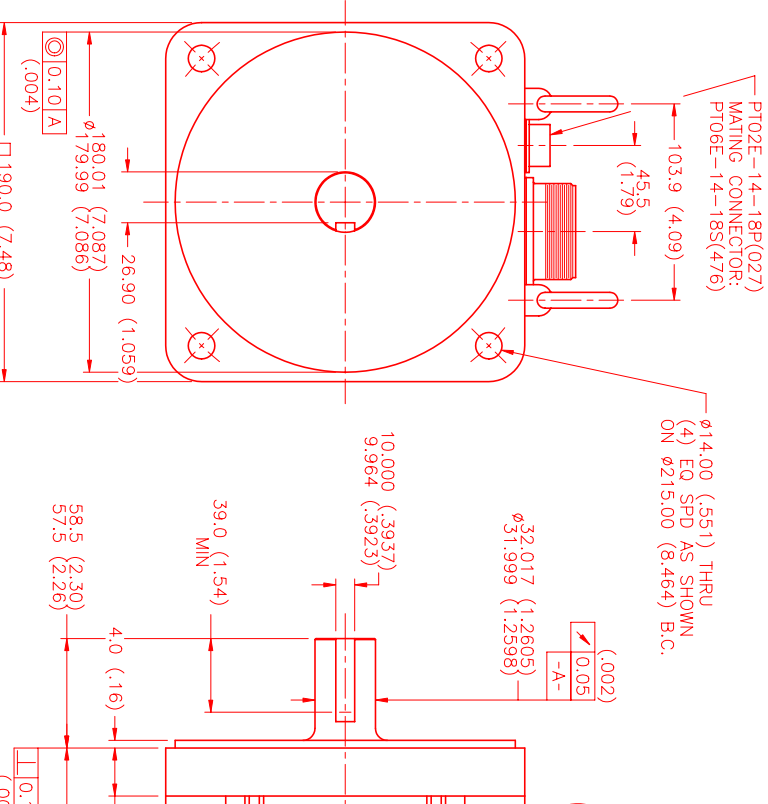

*MOTOR ROTATION C/W (COUNTER CLOCKWISE) (LOOKING AT THE FACE OF THE MOTOR)

WAVE REPRESENTING STATOR OUTPUT
WAVE REPRESENTING HALL SENSOR

NO.	PART NUMBER	DESCRIPTION	QTY.
1	MTS	MTS Systems Corporation Automation Division	

UNLESS OTHERWISE SPECIFIED:
DIMENSIONS ARE IN INCHES AND DECIMAL FRACTIONS ARE IN THOUSANDS OF AN INCH.
DIMENSIONS IN PARENTHESES ARE IN MILLIMETERS AND DECIMAL FRACTIONS ARE IN HUNDRETHS OF A MILLIMETER.
TOLERANCES UNLESS OTHERWISE SPECIFIED:
FRACTIONS DECIMAL ANGLES
FRACTIONS DECIMAL ANGLES
FRACTIONS DECIMAL ANGLES
FRACTIONS DECIMAL ANGLES

DATE: 8/13/99
DRAWN: MVS
CHECKED:
APPROVED:

SCALE: 1/2:1