

MotionPlus[®] TDC 100 and TDC 200

Temposonics[®] Digital Controllers

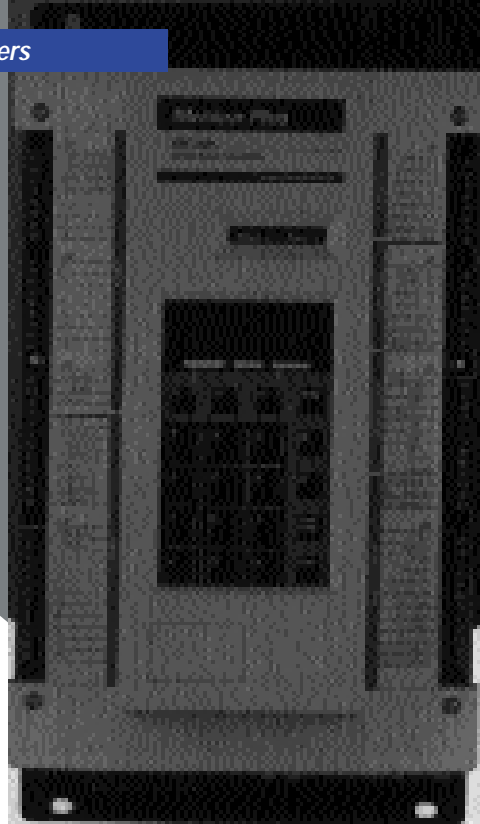

Features

- Highly accurate digital position control using Temposonics[®] LH and II position sensors
- Loop and calibration setup parameters are established in software. They can be edited and stored from the keypad or transmitted over the serial link
- Application program entered from the keypad, using menu-selected programming statements
- Programs in the two-axis model can run two axes independently, interlocked, or in ratio to one another
- Multiple controllers can be coordinated through digital I/O or multi-drop serial communications
- Programs contain readable statements like WAIT, REPEAT, and RAMP
- Up to eight programs for each axis can be stored internally
- Battery-backed RAM allows user programs and setup parameters to be saved while power is off
- Programmable I/O: 10 digital inputs and 12 digital outputs
- An external programmable controller can be used to select and run stored programs
- RS 232 or RS 485 serial port. RS 232 allows listing to a printer, external program storage and downloading, or remote operation of one unit. RS 485 allows remote operation of one to eight units
- Up to 99 variable parameters called presets can be included in the programs. An operator can then specify variables by entering values into presets at the keypad
- An access control input is available to restrict unauthorized program or setup changes
- Analog servo outputs can be set for current or voltage output
- LCD screen, displaying 4 lines of 16 characters each
- Optional SSP application software development for use on a personal computer

MotionPlus® TDC Controllers

The TDC Series of Motion Plus® Controllers combine the high performance of the Temposonics absolute linear position sensor with advanced direct digital servo control.

Two models are available: the TDC 100 for single-axis control, and the TDC 200 for dual-axis control. Each TDC Controller is a self-contained unit, ready to work right out of the box. It does not require any additional programming panels or electronics for interfacing to servo valves or electric servo drives. An integral keypad and LCD display are used for calibration, servo loop setup, programming, running programs, and monitoring.

Functional Description

The TDC 200 is designed as a complete stand-alone unit requiring no additional circuitry to implement two axes of Temposonics feedback servo control.

An integral keypad and LCD display are used to set up control parameters, to enter program steps, to monitor functions, to run programs, or to jog an axis directly.

Figure 1 illustrates the functional parts of the TDC 200. For each axis, the TDC 200 provides the following connections:

- A Temposonics sensor input interface
- A servo output interface
- Two limit inputs and a drive enable output
- A Run input, to start a selected program for the axis
- Three program select inputs, to select a program for the axis
- A Ready output, to indicate that a program is ready to run

The TDC 100 provides these same connections, but for one axis only. All connections except the ac power input use removable terminal blocks.

Operation

A TDC 200 or TDC 100 Controller unit can be used in the following ways:

- Independently, as a stand-alone control system. In this mode, the TDC Controller is programmed from the keypad. The stored programs can then be run from the keypad or by external switch or relay control. In addition, direct operator control is possible: an axis can be jogged or stepped from the keypad.
- With digital I/O connections to an external programmable logic controller. In this mode, stored programs are selected and started by the programmable controller. The programmable controller can also interact with the running program via the digital inputs and outputs.
- Integrated through the serial interface into a multiple controller system. In this mode, up to eight TDC Controllers can be connected to a host device (such as a personal computer or programmable controller) for two-way communications.

Transducer Interface

Each Temposonics position sensor interface is designed to work with a start/stop output, Temposonics LH or II sensor. Connections for + and – interrogator and gate output signals, +15 Vdc, –15 Vdc, +5 Vdc, and a ground for shielded connections for each interface are provided on a single terminal strip.

MotionPlus® EDC 100 and EDC 200 Encoder Digital Controllers

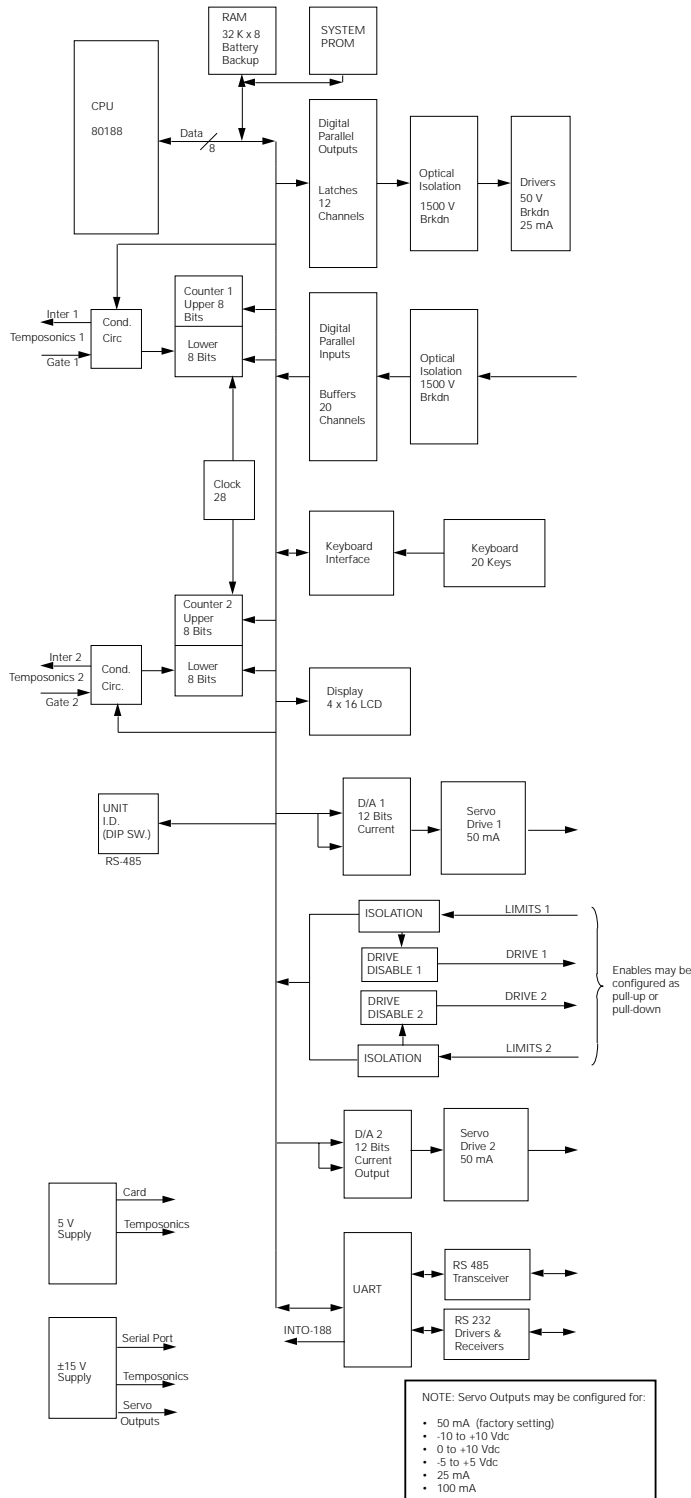

Figure 1. TDC 200 Block Diagram

Servo Interface

Each servo interface can be configured for a servo valve or a servo drive. The standard configuration is for a 50 mA current source connection. Jumper changes allow ± 10 V operation, while jumper and component changes can be made to provide other options (25 mA, 100 mA, ± 5 V, or 0 to 10 V).

Command Enable Module

Some drive or actuator systems do not have an enable input, which means they cannot take advantage of TDC enable control. The Model 475.71c Command Enable Module (not part of the TDC) provides an interface between a TDC Controller axis and those drive or actuator systems. The enable outputs of the TDC Controller are inactive (disabled), during power-up or power-down. This helps prevent sudden drive or actuator movement in case controller power is turned on or off while power is still applied to the drive or actuator. The Command Enable Module allows drive or actuator systems that do not have an enable input to be disabled during power-up or power-down of the TDC.

Serial Communications

The standard RS 232 serial interface allows programs and setup data to be sent to a printer or transferred to or from a personal computer or other external device. Alternatively, the RS 232 interface allows two-way communications with an external host (such as a personal computer or programmable controller).

The RS 485 serial communications mode (jumper selectable) allows a multi-drop configuration using a host plus up to eight TDC Controllers (controlling up to 16 axes).

TDC 100 Library Functions

Digital I/O

The TDC provides 20 inputs and 16 outputs, which can be operated on internal or external power.

Inputs

The 20 TDC inputs include the following:

Name	Function
Run X	Starts the currently selected program for Axis X.
X Select 1, 2, and 4	Selects a program for Axis X.
Run Y	Starts the currently selected program for Axis Y.
Y Select 1, 2, and 4	Selects a program for Axis Y.
Interlock	If off, stops the running program(s) and disables both axes.
Access	If off, allows operator to establish presets, run and monitor programs, but prevents operator access to programming and setup functions. The user may additionally define in software which menus and how many presets are available to the operator. (With the Access input on, everything is available.)

The remaining 10 inputs are user programmable. They can be used to tie external events to a running program. For example, if a “move next distance” switch for Axis X is connected to Input 1, then the program instruction WAIT TIL INPUT 1 can be used to make the running program stop at this point and wait for an operator response.

Outputs

The 16 TDC outputs include the following:

Name	Function
X Ready	Indicates that the X axis is not running a program and is clear of errors.
Y Ready	Indicates that the Y axis is not running a program and is clear of errors.
Status	Indicates that there are no errors on any axis.

Twelve outputs are user programmable. They can be used to tie external events to a running program. For example, if Output 10 is connected to an LED, then the program instruction OUT 10 ON AT 12.300 in can be used to turn on the LED when the axis is at or beyond the specified position.

Program Instruction Set

Instruction	Function
ACCEL n	Sets the acceleration for a trapezoidal move or ramp action, in units/s ²
DECEL n	Sets the deceleration for a trapezoidal move, in units/s ²
SET POSN TO n	Sets the desired position value for the current position.
VELOCITY n	Sets the velocity for a trapezoidal move, in units/s.
POSITION n	Calculates the distance and direction for an absolute trapezoidal move, based on the current position, and starts the move. The following options are available:
ALWAYS	Unconditional move.
IF INP m	Move starts only if specified input is on.
DISTANCE n	Sets the incremental distance and direction for a trapezoidal move and starts the move. The following options are available:
ALWAYS	Unconditional move.
IF INP m	Move starts only if specified input is on.
RATIO	(Available on TDC 200 two-axis controller only.) Ties the motion of one axis to that of the other, for simultaneous movement at some fixed ratio.
OFF	No ratioing (the default).
COMMAND n	Command. Allows the currently selected axis to follow the command signal of the other axis. The distance moved on the current (following) axis will be n* times the distance on the other axis.
FEEDBACK n	Feedback. Allows the currently selected axis to follow the feedback signal of the other axis. The distance moved on the current (following) axis will be n* times the distance on the other axis. *The ratio n can be in the range -8.0 to 8.0 (with presets, -32.0 to 32.0).
RAMP	Specifies a ramp at the current acceleration to a new velocity. The following options are available:
AT DIST n TO VEL m	Specifies the distance from the start of motion where the ramping will begin.
AT POSN n TO VEL m	Specifies the position where the ramping will begin.
FLAG n	Turns 1 of 12 internal flags on or off.
ON/OFF	Turns the specified flag on or off.
ON IF/OFF IF	Turns the specified flag on or off under a certain condition.
PR #n>	The condition: a preset is greater than (>); greater than or equal to (>=); less than (<); less than or equal to (<=) a value or another preset.
OUT n	Controls one of the 12 programmable outputs.
ON	Turns on output immediately.
OFF	Turns off output immediately.
ON AT m	Output (9 to 12 only) goes on when the axis is at or beyond a specified position.
OFF AT m	Output (9 to 12 only) goes off when the axis is at or beyond a specified position.
ADJUST PR#	Adjusts the value of a preset.
= VAL/POSN	Sets the preset equal to a value or the current (feedback) position.
+ VAL/POSN	Adds a value or the current (feedback) position.
* VAL/POSN	Multiplies by a value or the current (feedback) position.
/ VAL/POSN	Divides by a value or the current (feedback) position.
- VAL/POSN	Subtracts a value or the current (feedback) position.
ALWAYS	Makes the adjustment every time this program step is executed.
IF INP m	Makes the adjustment only if a specified input is on.
GOTO	Causes the program to jump to a specified program step, under specified conditions. The available options are:
ALWAYS	Unconditional jump.
IF INPUT m	Jumps only if a specified input is on.
IF FLAG m	Jumps only if a specified flag is on.
IF IN POSN	Jumps only if the actuator is in position.
IF NOT INPUT m	Jumps only if a specified input is off.
IF NOT FLAG m	Jumps only if a specified flag is off.
IF NOT IN POSN	Jumps only if the actuator is not in position.
REPEAT FROM STEP n	Repeats a program segment from Step n until one of the following conditions occurs:
FOR COUNT m	Repeats a specified number of times.
TIL INPUT m	Repeats until a specified input is turned on.
TIL FLAG m	Repeats until a specified flag is turned on.
WHILE INPUT m	Repeats while a specified input is on.
WHILE FLAG m	Repeats while a specified flag is on.
WAIT	Causes the program to wait for one of the following conditions:
FOR TIME n	Waits for a specified time.
TIL INPUT n	Waits until the specified input is on.
TIL INPOS	Waits until the axis is in position.
TIL FLAG n	Waits until the specified flag is on.
WHILE INPUT n	Waits until the specified input is off.
WHILE FLAG n	Waits until the specified flag is off.

Programming

```
PROGRAM MODE
AXIS# [ X ]
PROGRAM# 0
COPY EDIT LIST
```

Up to 8 programs can be created and stored on the

TDC for each available axis.

The Program mode is used to:

- COPY an existing program
- EDIT to create a new program or change an existing program
- LIST one or more programs to the printer

Programs are created by selecting the EDIT option, then using menus to enter program instructions. See previous page for program instruction set.

Setup

The Setup mode is used to set up Controller system parameters of the following types:

- Loop parameters for each axis
- Calibration parameters for each axis
- I/O assignment
- Communications baud rate
- Data transfer
- Preset names and value limits
- Access to menus and presets

Setup Loop Parameters

```
SETUP
[ X: LOOP ]
EDIT LIST
```

The position error is displayed while adjusting the

loop parameters for each axis.

These include the following:

- proportional gain (Kp)
- integrator multiplier (Ki)
- rate multiplier (Kd), the derivative of the feedback over time
- double rate (Kdd), an additional compensation, the second derivative of the feedback over time. Increases system stability
- feed forward (Kff), a compensation that decreases tracking error
- dither amplitude (for servo valves)
- excess error
- deadband compensation (for proportional valves)

Setup Calibration Parameters

```
SETUP
[ X: CALIB ]
EDIT LIST
```

The Calibration parameters for each axis.

These include the following:

- UNITS. The choices of unit labels are inches, feet, millimeters, centimeters, meters, and no unit labels
- UPDATE TIME. Time available for one reading of the Temposonics sensor(s) and update of the I/O and servo loops
- SCALE. A number relating the calibration setting of the Temposonics sensor to the units of measurement used by the controller
- Axis TYPE. Defines an axis as active or null (not in use)
- PLUS DIR. Defines the direction of motion as plus or minus, relative to the movement of the Temposonics magnet
- +/- GAIN. Compensates for hydraulic cylinder actuators in which the piston areas for retraction and extension are not equal
- Position OFFSET. Defines any position as the zero point
- IN POSITION. Value used by the program instruction WAIT TIL INPOS to determine when an actuator has reached its commanded position
Acceleration and velocity for jog motion can also be specified.

Other Setup Options

```

SETUP
[ OUT ASSGN ]
EDIT          LIST
    
```

I/O Assignment. Each of the 12 programmable outputs can be assigned to Axis X, Axis Y, both axes, or neither axis. An output assigned to an axis is automatically turned off at the end of a program on that axis.

```

SETUP
[ TRANSFER ]
STORE        LOAD
    
```

The Setup mode can be used to transfer data to or from external devices through the serial port. The data can include programs, setup parameters, and preset values.

```

SETUP
[ COMM ]
EDIT          LIST
    
```

The Setup mode can be used to set the communications baud rate.

```

SETUP
[ PRESET ]
EDIT          LIST
    
```

The Setup mode can be used to assign a name (of up to 16 characters) to any of the 99 presets, and to set a minimum and maximum limit for any preset. It can also be used to set the number of presets displayed.

Monitor

```

MONITOR [ POSN ]
X: 0.0000 rev
Y: 0.0000 rev
    
```

The Monitor mode is used to check the status of any

of the following:

- The position of the active axes
- The tracking or position error for the active axes
- The current step of the X program
- The current step of the Y program
- 10 digital inputs
- 12 digital outputs
- 12 flags
- Control I/O status for either axis
- Communications

Run

```

RUN MODE
AXIS [ X ]
PROGRAM# 0
RUN          JOG
    
```

The Run mode is used to operate an axis from the keypad in one of the following ways:

- Direct control from the keypad (using the JOG option)
- Select a program and run it (using the RUN option)

Presets

```

PRESET [ 20 ]
( 0.000000 )
SAVE          LIST
    
```

The Preset mode is used to assign values to variables known as “presets”.

Ninety-nine presets are available, designated PR #1 to PR #99. They can be used in any program to specify parameters such as position, velocity, acceleration and time. When a running program encounters a preset, it looks up the current value that has been assigned to it. Presets can be changed while a program is running.

Program Examples

Example 1. A Simple Motion Cycle

This example program demonstrates a simple motion cycle using digital I/O and time delays. At the start of the program, the actuator is moved to the 6-inch position. Output 1 is turned on when the actuator is in position, and remains on for 5 seconds. Then the actuator is moved to the 2-inch position. Output 2 is turned on when the actuator is in position, and remains on for 5 seconds. The entire cycle is repeated until Input 1 is turned on.

AXIS X PROGRAM 0

```
# 1 ACCEL 20.000 in/s^2
# 2 VELOCITY 2.000 in/sec
# 3 POSITION 6.000 in
# 4 WAIT TIL INPOS
# 5 OUT 1 ON
# 6 WAIT FOR TIME 5.000 sec
# 7 OUT 1 OFF
# 8 POSITION 2.000 in
# 9 WAIT TIL INPOS
# 10 OUT 2 ON
# 11 WAIT FOR TIME 5.000 sec
# 12 OUT 2 OFF
# 13 REPEAT FROM STEP 3
    TIL INPUT 1
# 14 END
```

Example 2. Using Presets

This example program uses the same basic motion cycle demonstrated in Example 1, but with the following changes:

- In Step 3, the position is determined by the value in Preset # 1
- In Step 6, the time is determined by the value in Preset # 3
- In Step 8, the position is determined by the value in Preset # 2

AXIS X PROGRAM 1

```
# 1 ACCEL 20.000 in/s^2
# 2 VELOCITY 2.000 in/sec
# 3 POSITION PR# 1 in
# 4 WAIT TIL INPOS
# 5 OUT 1 ON
# 6 WAIT FOR TIME PR# 3 sec
# 7 OUT 1 OFF
# 8 POSITION PR# 2 in
# 9 WAIT TIL INPOS
# 10 OUT 2 ON
# 11 WAIT FOR TIME 5.000 sec
# 12 OUT 2 OFF
# 13 REPEAT FROM STEP 3
    TIL INPUT 1
# 14 END
```

Example 3. Home Program

In this example, the program is used to home the axis. The home switch (normally closed) is connected to Input 10. The axis must start from a greater (more positive) position than the home position and less than 25 inches away. The axis first moves towards the home switch at 1 inch/second. When the switch opens, the axis decelerates to rest and then moves in the opposite direction in 0.001-inch increments until the switch closes again.

AXIS X PROGRAM 5

```
# 1 ACCEL 10.000 in /s^2
# 2 VELOCITY 1.000 in /sec
# 3 DISTANCE -25.00 in
# 4 WAIT WHILE INP 10
# 5 RAMP DIST 0.000 in
    VEL 0.000 in
# 6 WAIT TIL INPOS
# 7 DISTANCE 0.001 in
# 8 REPEAT FROM STEP 7
    TIL INPUT 10
# 9 END
```

Example 4. Programmable Limits

This program shows how Outputs 9 to 12 can function as programmable limit switches. The program could be used as the beginning of a longer program. The limit switch functions will remain in effect as long as the program is running.

AXIS X PROGRAM 3

```
# 1  OUT 9 ON AT 1.000 in
# 2  OUT 10 ON AT 2.000 in
# 3  OUT 11 ON AT 3.000 in
# 4  OUT 12 ON AT 4.000 in
# 5  OUT 9 OFF AT 4.500 in
# 6  OUT 10 OFF AT 5.000 in
# 7  OUT 11 OFF AT 5.500 in
# 8  OUT 12 OFF AT 6.000 in
# 9  WAIT TIL INPUT 1
# 10 END
```

Example 5. Ramp Motion

This program shows how ramping instructions can be used to build a complex motion profile.

Notice that:

- A DISTANCE or POSITION instruction must be used to start motion in the desired direction, before any RAMP instruction
- The ramp starts when the system reads its present position and finds that the actuator has passed the point specified by DIST or POSN in the RAMP instruction
- To change direction, it is necessary to first ramp to 0, then begin motion in the opposite direction and define a ramp
- Acceleration rates may be

changed between ramps

```
# 1  ACCEL 10.000 in /s^2
# 2  VELOCITY 2.000 in /sec
# 3  POSITION 20.000 in
# 4  WAIT TIL INPUT 1
# 5  POSITION 2.000 in
# 6  RAMP POSN 18.000 in
      VEL 4.000 in
# 7  ACCEL 5.000 in/s^2
# 8  RAMP POSN 15.000 in
      VEL 1.000 in
# 9  RAMP POSN 12.000 in
      VEL 3.000 in
# 10 ACCEL 10.000 in /s^2
# 11 RAMP POSN 4.000 in
      VEL 0.000 in
# 12 WAIT FOR TIME 4.000 sec
# 13 REPEAT FROM STEP 1
      TIL INPUT 2
# 14 END
```

Program Examples Continued

Example 6. Two-Axis Operation with Ratio

In this program Axis X, the master, is started first. Axis Y follows in a 1 to 1 ratio with the X axis command. Both axes move to the position 49 inches. Then Flag 1 is used to synchronize the start of the ratioed movement. Axis X then cycles between the positions 20 inches and 45 inches, with Axis Y following. When Input 10 comes on, both programs stop.

AXIS X PROGRAM 6

```
# 1 ACCEL 10.000 in /s^2
# 2 VELOCITY 3.000 in /sec
# 3 FLAG 1 OFF
# 4 POSITION 49.000 in
# 5 WAIT TIL INPOS
# 6 WAIT TIL FLAG 1
# 7 POSITION 20.000 in
# 8 WAIT TIL INPOS
# 9 POSITION 45.000 in
# 10 REPEAT FROM STEP 8
      TIL INPUT 10
# 11 END
```

AXIS Y PROGRAM 6

```
# 1 ACCEL 10.000 in /s^2
# 2 VELOCITY 3.000 in /sec
# 3 POSITION 49.000 in
# 4 WAIT TIL INPOS
# 5 RATIO COMMAND
      1.0000
# 6 FLAG 1 ON
# 7 WAIT TIL INPUT 10
# 8 RATIO OFF
# 9 END
```

Dimensions

Figure 2 shows the mounting dimensions of the TDC Series Controllers and Figure 3 shows the overall dimensions and space requirements.

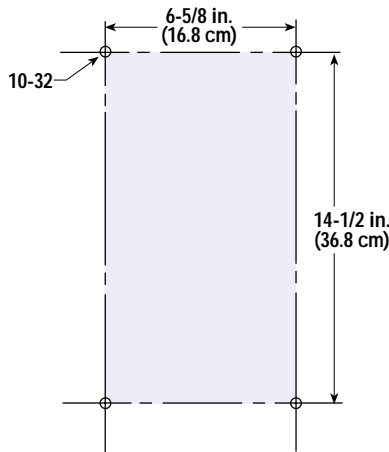

Figure 3. Mounting Dimensions

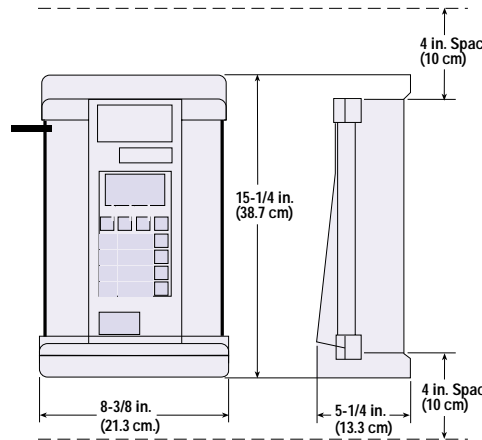

Figure 4. Overall Dimensions

Serial Communications Messages

Up to eight TDC Controller units can be connected to an external Host for two-way communications. The Host may be a terminal, a personal computer, a programmable controller, or any

other device capable of two-way communications (RS 232 or RS 485). Each unit communicates with the Host only, and not with other units. The Host sends commands or data requests to

the unit. If the unit is in RS 232 mode, or is the only unit selected (by a CU command) in the RS 485 mode, it can respond with data, acknowledgment, or non-acknowledgment messages.

TDC Serial Commands

CUn	Select Controller unit n.																		
CA	Select all Controller units.																		
CDn	Set the response delay to n milliseconds (0—1000).																		
CE	Echo ON.																		
CL	Echo with extra linefeed ON.																		
CF	Echo OFF.																		
CS	To set the protocol for short (unchecked) commands.																		
CC	To set the protocol for checked commands that include a checksum digit.																		
C2	Switch to RS 232 mode.																		
C4	Switch to RS 485 mode.																		
CT	Store programs and parameters.																		
RXRn	Run program n on axis X.																		
RXJ>	Run at jog speed in the clockwise (or extend) direction on axis X.																		
RXJ<	Run at jog speed in the counterclockwise (or retract) direction on axis X.																		
RXS	Stop motion on axis X.																		
RX>	Jog axis X one step in the clockwise (or extend) direction.																		
RX<	Jog axis X one step in the counterclockwise (or retract) direction.																		
SLXPn	Set the proportional gain (Kp) to n for axis X.																		
SLXIn	Set the integrator constant (Ki) to n for axis X.																		
SLXDn	Set the velocity or rate constant (Kd) to n for axis X.																		
SLXAn	Set the acceleration or double rate constant (Kdd) to n for axis X.																		
SLXFn	Set the feedforward constant (Kff) to n for axis X.																		
SLXXn	Set the excess error to n for axis X.																		
SLXRn	Set dither amplitude for axis X.																		
SLXBn	Set deadband compensation for axis X.																		
SCXUunits	Set the axis X displayed units to one of the following: <table border="1" style="margin-left: 20px;"> <thead> <tr> <th>Units</th> <th>Displayed Units</th> </tr> </thead> <tbody> <tr><td>D</td><td>degrees</td></tr> <tr><td>R</td><td>revolutions</td></tr> <tr><td>I</td><td>inches</td></tr> <tr><td>F</td><td>feet</td></tr> <tr><td>MM</td><td>millimeters</td></tr> <tr><td>C</td><td>centimeters</td></tr> <tr><td>M</td><td>meters</td></tr> <tr><td>N</td><td>no units (increments of resolution)</td></tr> </tbody> </table>	Units	Displayed Units	D	degrees	R	revolutions	I	inches	F	feet	MM	millimeters	C	centimeters	M	meters	N	no units (increments of resolution)
Units	Displayed Units																		
D	degrees																		
R	revolutions																		
I	inches																		
F	feet																		
MM	millimeters																		
C	centimeters																		
M	meters																		
N	no units (increments of resolution)																		
SCXDn	Set the update time for the X axis.																		
SCXS_n	Set the scale for the X axis.																		
SCXAn	Set the jog acceleration for the X axis.																		
SCXVn	Set the jog velocity for the X axis.																		
SCXTtype	Set axis type (A=active or N=null) for axis X.																		
SCXDdir	Set the plus direction for motion on the X axis to one of the following: <table border="1" style="margin-left: 20px;"> <tbody> <tr><td>dir</td><td>direction</td></tr> <tr><td>C</td><td>clockwise</td></tr> <tr><td>W</td><td>counterclockwise</td></tr> <tr><td>R</td><td>retraction</td></tr> <tr><td>E</td><td>extension</td></tr> </tbody> </table>	dir	direction	C	clockwise	W	counterclockwise	R	retraction	E	extension								
dir	direction																		
C	clockwise																		
W	counterclockwise																		
R	retraction																		
E	extension																		
SCXNn	Set the X axis +/- gain to n.																		
SCXOn	Set the offset distance for axis X.																		
SCXPn	Set the in position distance for axis X.																		
Slcccccccccc	Assign programmable outputs 1 to 12 to axis X (X), axis Y (Y), both (B), or neither (N).																		
AAE	Enable all menus.																		
AAD	Disable all menus.																		
ASE	Enable the Setup menu.																		
ASD	Disable the Setup menu.																		
ASS	Enable Setup menu in Start up mode.																		
AME	Enable the Monitor menu.																		

TDC Serial Commands, continued

AMD	Disable the Monitor menu.	
AMS	Enable Monitor menu in Setup mode.	
ARE	Enable the Run menu.	
ARD	Disable the Run menu.	
APE	Enable the Preset menu.	
ARS	Enable Run menu in Start up mode.	
APD	Disable the Preset menu.	
APS	Enable Preset menu in Start up mode.	
AGE	Enable the Program menu.	
AGD	Disable the Program menu.	
AGS	Enable Program menu in Start up mode.	
Pnr	Set preset #n (01 to 99) to the value r.	
PNncccccccccccccc	Name a preset.	
PLnr	Set the minimum limit of preset n to r.	
PUnr	Set the maximum limit of preset n to r.	
IPX	Request the feedback position of axis X.	
IEX	Request the error on axis X.	
II	Request the status of all 10 programmable inputs. The Controller unit responds with an acknowledgment message (A) plus a 10-digit number showing the status of all 10 inputs. The status of each input is represented by one digit, which can be 0 (OFF) or 1 (ON).	
IO	Request the status of all 12 programmable outputs. The Controller unit responds with an acknowledgment message (A) plus a 12-digit number showing the status of all 12 outputs. The status of each output is represented by one digit, which can be 0 (OFF) or 1 (ON).	
IF	Request the status of all 12 internal flags. The Controller unit responds with an acknowledgment message (A) plus a 12-digit number showing the status of all 12 flags. The status of each flag is represented by one digit, which can be 0 (OFF) or 1 (ON).	
IA	Request current access setting.	
ISX or ISY	Request the status of all 11 control inputs and outputs. The Controller unit responds with an acknowledgment message (A) plus an 11-digit number showing the status of all 11 control I/Os. The status of each control is represented by one digit, which can be 0 (OFF) or 1 (ON).	
	Digit	Input or Output
	1	+ Limit for this axis.
	2	- Limit for this axis.
	3	Run input for this axis.
	4	Program Select 1 for this axis.
	5	Program Select 2 for this axis.
	6	Program Select 4 for this axis.
	7	Interlock input.
	8	Access input.
	9	Ready output for this axis.
	10	Enable output for this axis.
	11	Status output.
IVn	Request the value of Preset #n (0 to 99).	
INn	Request preset minimum.	
IXn	Request preset maximum.	
IUX	Request running Status for x axis.	
IUY	Request running Status for y axis.	
IR	Request version of firmware.	
Fnm	Set or clear a flag.	
Controller-to-Host Messages	Acknowledgement	A <CR>.
	Acknowledgment Plus Data	A [data]<CR>.
	Non-acknowledgment, as follows:	
	N1	Bad checksum.
	N2	Bad format.
	N3	Reject data.
	N4	Data unavailable.

Most commands are shown for Axis X only. Axis Y commands are similar.

Motion Plus® TDC 100 & 200 Specifications

Parameter	Specification
CPU	12.5 MHz 80188 microprocessor
Memory	
System EPROM	Up to 64K
CMOS battery-backed RAM	32K
Digital Outputs	12 user-programmable outputs
	3 dedicated outputs (X Ready, Y Ready, Status)
	Optical isolation
	Current sourcing (25 mA maximum at 15 Vdc)
	(75 mA maximum with external 24 Vdc supply)
	Active high (ON = high)
Digital Inputs	10 user-programmable inputs
	10 dedicated inputs (X Program
	Select, Y Program Select, X Run, Y Run, Interlock, Access)
	Optical isolation
	Current sinking (10 mA maximum)
	(10 Vdc minimum to 24 Vdc maximum for active high)
	Active high
Limits	4 limit inputs (+X, -X, +Y, -Y)
	Current sourcing, 10 mA maximum current
	Active high (ON = high)
	Optical isolation
Servo Outputs	50 mA standard
Options	-10 to +10 Vdc (jumper selectable)
	-5 to +5 Vdc (jumper selectable)
	0 to +10 Vdc (component change required)
	25 mA (component change required)
	100 mA (component change required)
Drive Enable	Active low, 100 mA maximum current
	(Optional active high with jumper change)
Temposonics Interface	Interface to two Temposonics II or LH digital transducers (TDC 200) or one Temposonics II or LH digital transducer (TDC 100)
Serial Interface	RS 232/RS 485 option (with jumper change) modem option (with jumper change)
LCD Display	4 lines X 16 characters
Keypad	20 keys, including 3 function keys
Power Input	90 to 264 Vac, 47 to 63 Hz, 115 Vac, 2 A continuous, 230 Vac, 1 A continuous
Optional External Power Supplies	Can be used for: servo outputs (jumper changes required)
	+15 V to +24 V, 0.25 A
	-15 V to -24 V, 0.25 A
	Digital I/O (jumper changes required)
	+15 V to +24 V (current depends on loads)
	Temposonics sensors (jumper changes required)
	+5 Vdc (±5%), 1 A
	+15 Vdc (±5%), 0.5 A
	-15 Vdc (±5%), 0.25 A
Environmental Conditions	
Temperature	0° to 50° C
Humidity	10% to 90% humidity, noncondensing
Overall Dimensions	Height: 15.25 in. (38.7 cm)
	Width: 8.375 in. (21.3 cm)
	Depth: 5.25 in. (13.3 cm)
Weight	7.5 lb. (3.4 kg)

Specifications are subject to change without notice. Contact MTS Automation for verification of specifications critical to your needs.

OptionsSSP Software

The EDC/TDC Software Support Package is an off-line programming system for EDC or TDC Controllers. The Package is designed to operate on IBM®PC, XT, AT, PS/2 and 100% compatible computers. It allows you to create and store complete programming tasks in a single file called a program session.

At MTS Automation our experienced application engineers are ready to work with you to design motor, amplifier and motion control packages to meet your performance, size and durability requirements exactly. For specific ordering information, please visit our web site at www.mtsautomation.com, or call the factory at 1-800-967-1785.

Call Today,
1-800-967-1785
www.mtsautomation.com



MTS Automation

Custom Servo Motors

2121 South Bridge St.
New Ulm, Minnesota 56073
Phone: 507-354-1616
Fax: 507-354-1611

Custom Servo Motors Antriebstechnik GmbH & Co. KG

Leinenweberstr. 14
D-79108 Freiburg
Tel: +49 761 1 30 91-0
Fax: +49 761 1 34 42

Performance Controls

433 Caredean Drive
Horsham, Pennsylvania 19044
Phone: 215-675-6500
Fax: 215-674-8714