



230 Series

AMPLIFIER

MAS-230
80-260 VAC
45-65Hz

Multi-Axis Amplifiers include the features of the MPA family with these additional offerings.

- Economical and Space Saving Design
- Convenient Front Panel Switch Settings
- Simplified set-up

Encoder Line Count

50, 1000, 1024, and 2000

Fault Indicators

Bus
Thermal
Soft Start
Motor
Feedback
Bridge

Status Indicators

Power
Ready
Reset
Disable/Enable
Current
Velocity
Marker

Input/Output Interface Analog Signals

- Velocity/Torque Command Input:
Differential Input 0 to ± 10 Vdc (15 Vdc Maximum)
- Auxiliary Input:
Differential Input 0 to ± 10 VDC (15 Vdc Maximum)
- Velocity Output: (Switch Selectable)
2.07 Volts Per 1000 rpm
- Current Output
± 10 Volts = ± Peak Current

Input/ Output Interface 24 Volt Logic:

Inputs

- RES (Reset)
- ENABLE (Enable)
- V/T (Velocity/ Torque) Select

Output

- Fault (Open Collector)
- Ready (Open Collector)

Switch Configurations

- Pole Setting
- Tach Gradient
- Encoder Line Count
- Filtering

Adjustments

- BAL (Balance)
- CUR (0-Peak Current Limit)
- RSP (Response)
- LD (Lead)
- COM (Command)
- AUX (Auxiliary)

Options

- External Shunts
- Brushless Tachometer Input
- Separate Logic Supply

Amplifier Modules

Model	Continuous Output Current	Peak Output Current*	PWM Frequency	Weight
AC-03	3 amps	6 amps	18KHz	4.0 lbs.[1.8Kg]
AC-07	7 amps	14 amps	18KHz	4.0 lbs.[1.8Kg]
AC-10	10 amps	20 amps	18KHz	4.0 lbs.[1.8Kg]
AC-15 (-335)	12.5 amps	30 amps	18KHz	4.0 lbs.[1.8Kg]
AC-15	15 amps	30 amps	18KHz	4.2 lbs.[1.9Kg]

*Peak Current ≥ 1 second.

Power Supply Modules

Model	AC Input 1 ø Line Current	AC Input 3 ø Line Current	Amps	Shunt Capacity Internal	Shunt Capacity External	Weight
PS015	18 amps	11 amps	15	16 amps peak, 300 Watts, 85°C	N/A	5.0 lbs.[2.3Kg]
PS030	36 amps	22 amps	30	32 amps peak, 300 Watts, 85°C	N/A	7.2 lbs.[32.0Kg]
PS060	72 amps	44 amps	60	32 amps peak, 300 Watts, 85°C	64 amps peak, 600 Watts, 85°C	17.0 lbs.[7.7Kg]

Mechanical Footprints

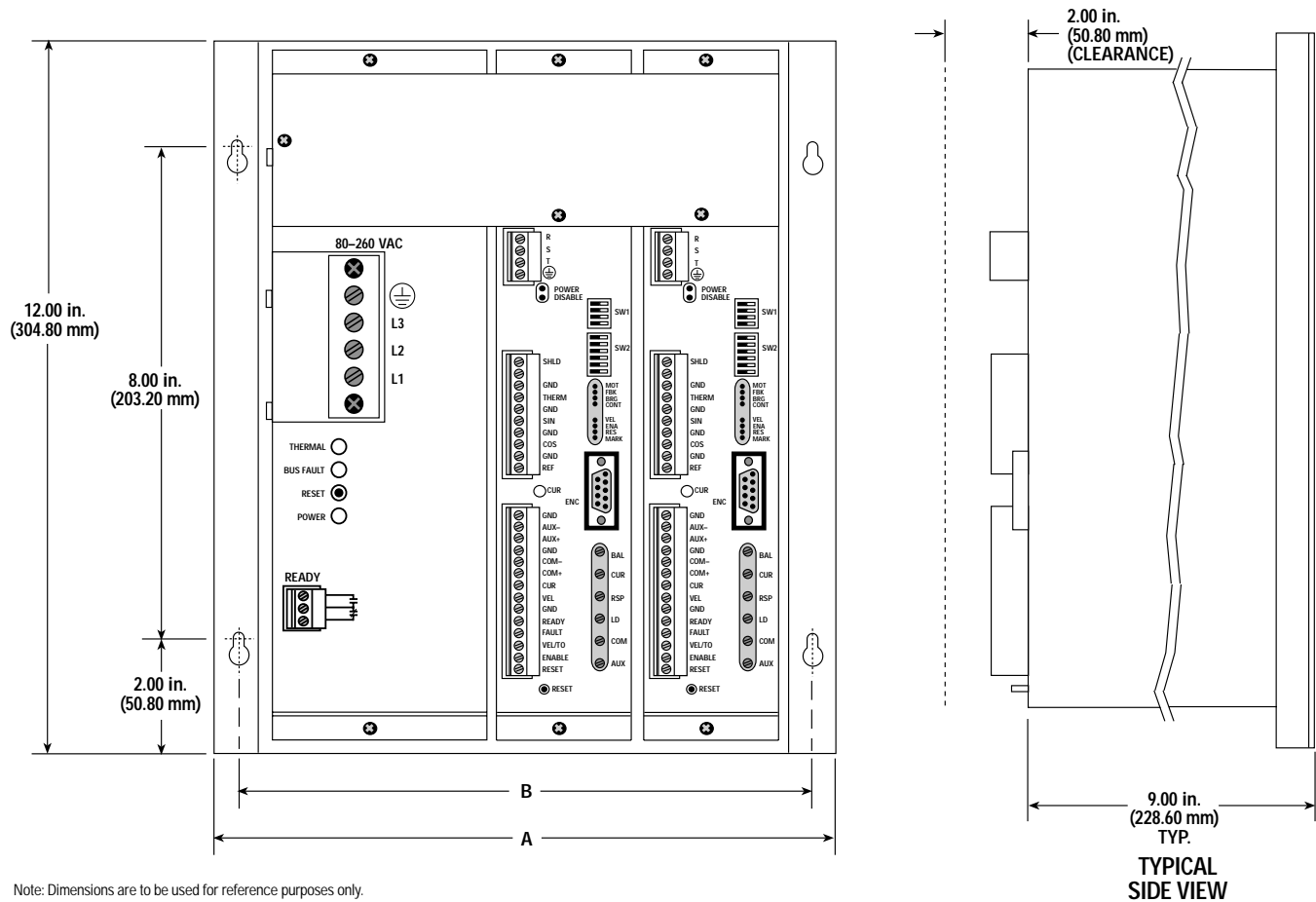

Multi-Axis Baseplate Dimensions

Model	A in.[mm]	B in.[mm]
MAS02/	10.05[255.27]	9.25[234.95]
MAS03/	12.30[312.42]	11.50[292.10]
MAS04/	14.55[369.57]	13.75[349.25]
MAS05/	16.80[426.72]	16.00[406.40]
MAS06/	19.05[483.87]	18.25[463.55]
MAS07/	21.90[556.26]	20.70[525.78]
MAS08/	24.15[613.41]	22.95[582.93]
MAS09/	26.40[670.56]	25.20[640.08]
MAS10/	28.65[727.71]	27.45[697.23]

Multi-Axis Systems will include:

- Power Supply
- Baseplate
- Amplifier modules
- Bus Bar
- Bus Cover
- Hardware screws, etc.
- System Label

Wiring Diagram

Connection Diagram

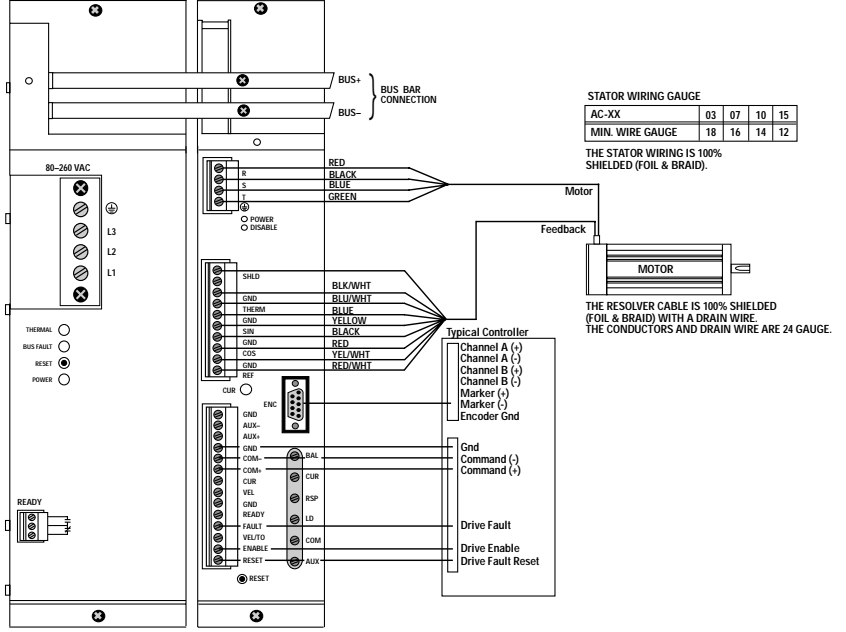
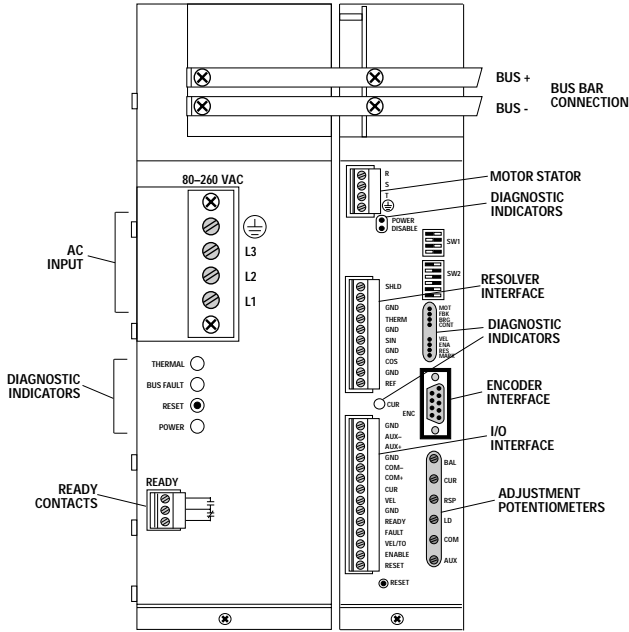

Example of a Multi-Axis System

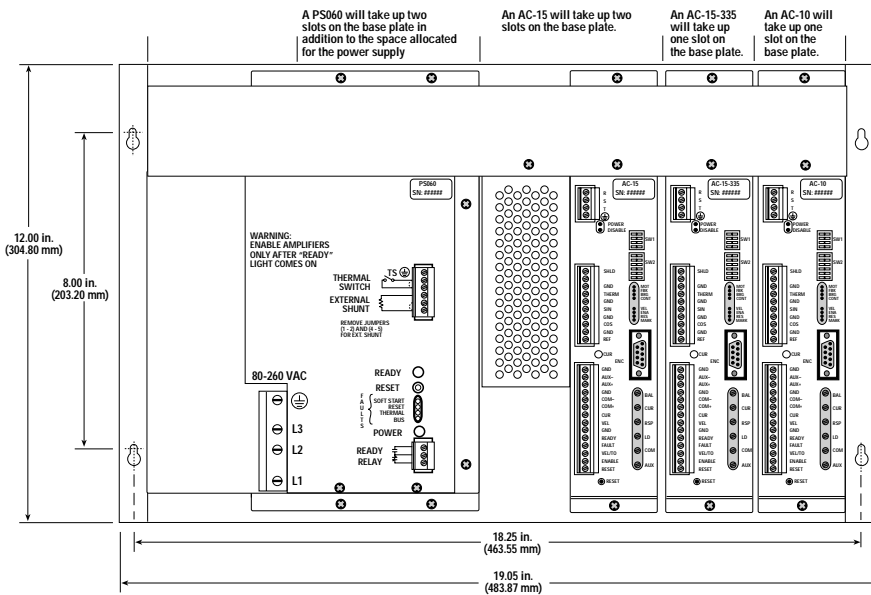

Slot Requirements

Model	Slot*
PS015	0
PS030	0
PS060	2
AC-03/07/10	1
AC-15 (-335)	1
AC-15	2

* Number of slots in addition to the base power supply.

This example demonstrates how a three-axis system could require an MAS06/base plate.

Ordering Chart for Power Supplies

Example MAS02/015-XXXX*

Multi-Axis System	Available Slots	/	Available Power Supply	-	XXXX*
MAS	02 = 2 slot		015 = 15 amp		4 Digit number will specify the number and kind of module, bus bars & hardware. All systems will have a dash number.**
	03 = 3 slot		030 = 30 amp		
	04 = 4 slot		060 = 60 amp		
	05 = 5 slot		15A = 15 amp/separate supply (120VAC)		
	06 = 6 slot		30A = 30 amp/separate supply (120VAC)		
	07 = 7 slot		60A = 60 amp/separate supply (120VAC)		
	08 = 8 slot		15D = 15 amp/separate supply (24VDC)		
	09 = 9 slot		30D = 30 amp/separate supply (24VDC)		
	10 = 10 slot		60D = 60 amp/separate supply (24VDC)		
			30E = 30 amp/separate supply (120VAC) external shunts		

* Please contact engineering department for exact part number after system is specified and order is placed.

** Largest modules need to be placed closest to power supply.

Ordering Chart for Amplifier Modules

Example AC-03-T1

Modules	-	Amps	-	Options
AC		03-3 amps		T1-Bushless Tach Option
		07-7 amps		S-Separate Logic Supply, 120 VAC
		10-10 amps		
		15-12.5 amps (-335)		24VS-Separate Logic Supply, 24 VDC
		15-15 amps		

Note 1: Expansion options are available-Consult Factory.

Separate Supply Options

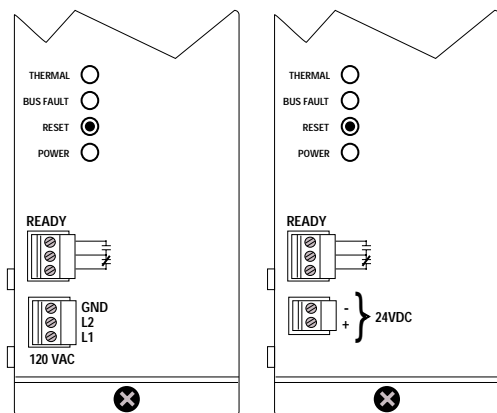

Tach Option

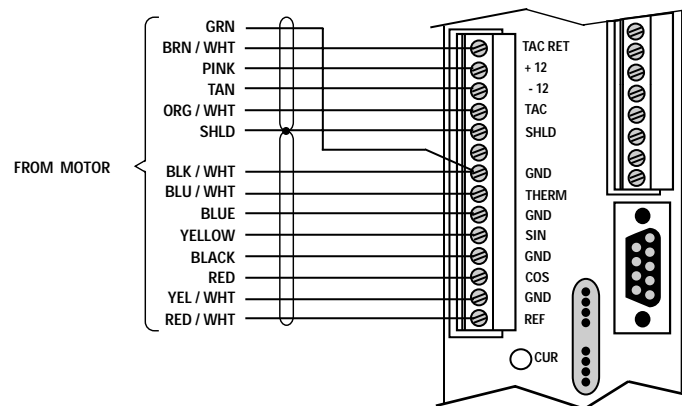

Separate Supply Option – This option keeps the logic supply powered to retain current position.

Tach Option – Allows an analog tachometer feedback to be used with the drive. The input is fed directly into the velocity feedback loop for better performance. When this option is required, the feedback wiring is extended to facilitate the additional signals.