

The MaxPlus® SFD 230
Connectivity and ease of use
in a compact, cost-effective
digital solution.

Meeting your expectations.

At the MTS Systems Corporation, Automation Division, we have a reputation for understanding our customer's needs, and then delivering solid, price/performance solutions. The SFD 230 continues our tradition of customer-driven design, with an impressive list of the attributes design engineers want in a digital drive.

- Selectable modes of operation
 - Current (Torque)
 - Velocity
 - Velocity with programmable ramps (Stand alone velocity control)
 - Position Loop with 16 BCD selectable indexes
 - Stepper Emulation (Step and Direction)
- Compact size
- High bandwidth
 - Combination of digital and analog technology, yields the best of both worlds
 - No potentiometers and extremely stiff velocity and position loops
- Low-cost high performance digital drive
- Screw terminal connectors
 - No proprietary breakout boards or cables required
- Quick setup user friendly HMI
- No line transformer required
 - Direct 115VAC to 260VAC single phase input
- Optically isolated I/O
- Selectable feedback versions
 - Resolver (Sine commutation) with emulated 1024 line encoder output
 - Encoder with hall (Trapezoidal commutation)
- Selectable Command Options
 - One +/- 10V analog input for current or velocity command
 - RS232 serial control
 - Stand alone digital for indexing or pulse and direction
- RS485 Multi drop communications

- Built in shunt with provisions for an external shunt resistor if required
- Internal or external 24VDC logic supply
- Analog monitor outputs for current, velocity and command
- CE and UL
- Optimized for the broad range of MTS Servo Motors
- Fast delivery
- Outstanding service and support

The MaxPlus® SFD 230 gives you the flexibility of operating in current, velocity, velocity with defined ramp function, position-loop mode and stepper-mode interface. Moves are stored in the controller and activated by digital I/Os. We also offer a +/-10V analog command input for current and velocity loop control. An internal shunt resistor is provided for most common applications, with an external shunt resistor optional.

SFD - think of it as a Smaller, Friendlier Drive.

Smaller size makes it easy to fit the MaxPlus SFD 230 into almost any enclosure. It operates at extremely low noise levels. In addition, the MaxPlus SFD 230 is extremely user-friendly. There's no learning curve to overcome. The easy HMI under Windows™ means you can take it out of the box, load the software and be up and running in minutes.

MTS Automation has the total solution for high-volume applications.

The SFD 230 drive gives OEMs the ability to take full advantage of the broad range of servo motors offered by MTS Automation. The result is a cost-effective solution for this power range. And, one that delivers incredible consistency, unit-to-unit, for high-volume applications.

You can configure complete, matched systems with MaxPlus SFD 230 drives and MaxPlus servo motors, or you can use the MaxPlus SFD 230 with other manufacturers' motors, whichever combination is best for you.

Technological advances that produce results.

We are continually working with new and emerging technologies to improve our product offering. It is the mission of the MTS Automation Division to continually improve the quality, reliability and cost effectiveness of our products, while achieving higher levels of performance.

We deliver. Two ways.

We are prepared to deliver the products you need, when you need them. Historically, the MTS Automation Division has some of the fastest turn-around times in the industry. When do you need your order? We'll find a way to get it there.

And the MTS Automation Division delivers when it comes to support. Our experienced application engineers are ready to work with you to design motor, amplifier and motion control packages to meet your performance, size and durability requirements exactly. If for any reason your application seems to fall outside the parameters of these specifications, please contact MTS Automation to discuss the possibility of a custom solution.

MaxPlus SFD 230 Technical Data

- User-friendly HMI
- Power output 1 to 2kW
- Continuous current 3 to 6A
- Peak current 6 to 12A
- AC input voltage 115V, 230VAC
- RS485 and RS232 Communications Interface
- Dimensions 7.9 in. (200mm) x 6.3 in. (160mm) x 3.0 in. (75mm)
- Encoder and Resolver feedback



Call Today,
1-800-967-1785
www.mtsautomation.com

MaxPlus® is a registered trademark of MTS Systems Corporation.
©2001 MTS Systems Corporation.

**MTS Systems Corporation
Automation Division**

2101 North Broadway
New Ulm, Minnesota 56073
Phone: 507-354-1616
Fax: 507-354-1611

**MTS Systems GmbH & Co. KG
Automation Division**

Riegelstrasse 2
79111 Freiburg Germany
Tel: +49 761 1 30 91-0
Fax: +49 761 1 34 42

230 Series

VOLT AMPLIFIER

SFD-03, 06
115-230 VAC
50-65 Hz

Amplifier Specifications

Series	SFD230/3LR SFD230/3HR	SFD230/6LR SFD230/6HR	SFD230/3LI SFD230/3HI	SFD230/6LI SFD230/6HI
Input Voltage	115-260VAC	115-260VAC	115-260VAC	115-260VAC
Continuous Output Current (rms)	3A	6A	3A	6A
Peak Output Current (rms)	6A	12A	6A	12A
Bus Voltage Min/Max	100 / 375VDC	100 / 375VDC	100 / 375VDC	100 / 375VDC
Recommended Fuses External	6A	12A	6A	12A
Input Current at Output Peak Power	9A	18A	9A	18A
Input Current at Output				
Continuous Power	4.5A	9A	4.5A	9A
Minimum Load Inductance	3.2mH	1.6mH	3.2mH	1.6mH
Dimensions	200x160x75mm 7.9x 6.3x 3.0 in	200x160x85mm 7.9x 6.3x 3.3 in	200x160x75mm 7.9x 6.3x 3.0 in	200x160x85mm 7.9x 6.3x 3.3 in
Weight	2.6Kg	2.8Kg	2.6Kg	2.8kg
AC Inrush Current (peak)	22A	44A	22A	44A
Efficiency	96%			
Clock Frequency (normal/low noise)	9.5kHz/19kHz			
Current Ripple Frequency (normal/low noise)	19kHz/38kHz			
Current Controller Bandwidth	1kHz			
DC Logic Supply	"L"- Versions - 24VDC 0.5A externally supplied by user "H"- Versions - derived internally from DC-BUS			
DC Voltage for External Use	+5V / 200mA			
Analog Command Input	± 10V differential			
Internal Resistance	20Ω			
Feedback Type	Resolver		Incremental Encoder / Hall Effects	
Electronic Commutation	Sinusoidal		Trapezoidal	
Feedback Specifications	Resolver: 2 Poles Transmission Ratio 0.5 Input Voltage 7Vrms; 10kHz		Encoder: Voltage 5V Open Collector to 0V or Differential Line Driver 5V/0V Internal Resistance: 1K Halls: Open Collector to 0V Pulled up to 15V or 5V by 4.7K	
Velocity Loop Scaling	5V = 6000 RPM		5V = 12.5@100 kHz. Encoder Frequency (Programmable in HMI)	
Monitor outputs for conditioned velocity, commanded speed and current values			Analog Output +/- 5V External Load >10kΩ Use Only Short Shielded Line	
Logic Inputs:	Active >12V/>4mA; Inactive <2.5V/<1mA			
Optically Isolated	Ri = 3.3K ; Max. Voltage: 30V			
Optically Isolated Status Outputs only for ohmic loads	pnp- open collector Max. 40V Max. 50mA			
Ready Output	Potential-Free Relay Contact Max. 10W at 100V, 100mA			

Connection Diagrams

Resolver

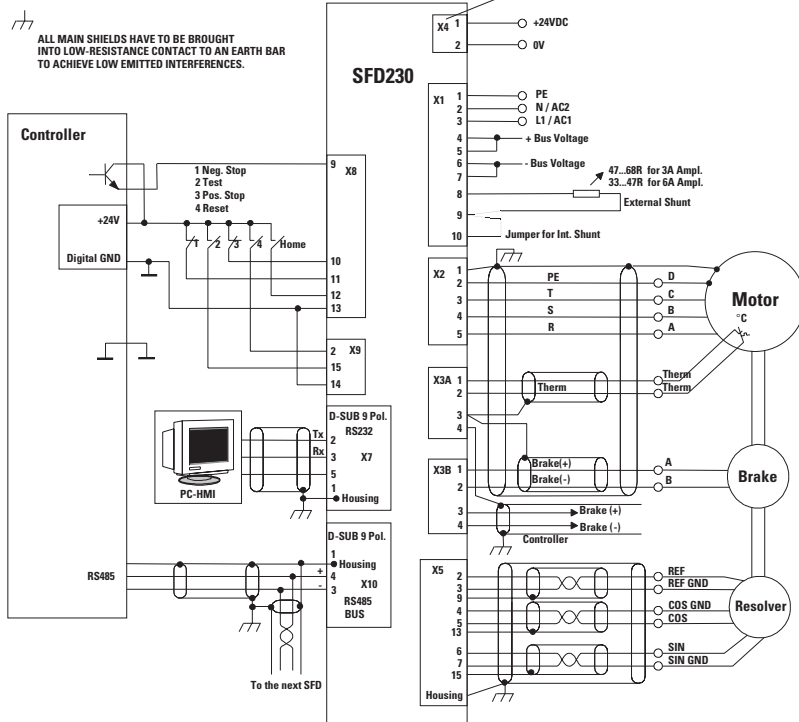

Connections

Power amplifier:

- 1x Phoenix MSTB2.5 10-Poles (Supply/Shunt)
- 1x Phoenix IC2.5 5-Poles (Motor)
- 2x Phoenix MC1.5 4-Poles (Motor Brake/Thermo)
- 1x Phoenix MC1.5 2-Poles (24V-Supply)

Controller part:

- 1x Connector Weidmüller 16-Poles (IO)
- 1x D-SUB 25-Poles (IO)
- 1x D-SUB 15-Poles (Encoder/Resolver)
- 2x D-SUB 9-Poles, Connector (BUS and ENCODER OUT)
- 1x D-SUB 9-Poles, Socket (RS232)
- 1x 10-Poles Low-Profile Header (Diagnosis)

Encoder

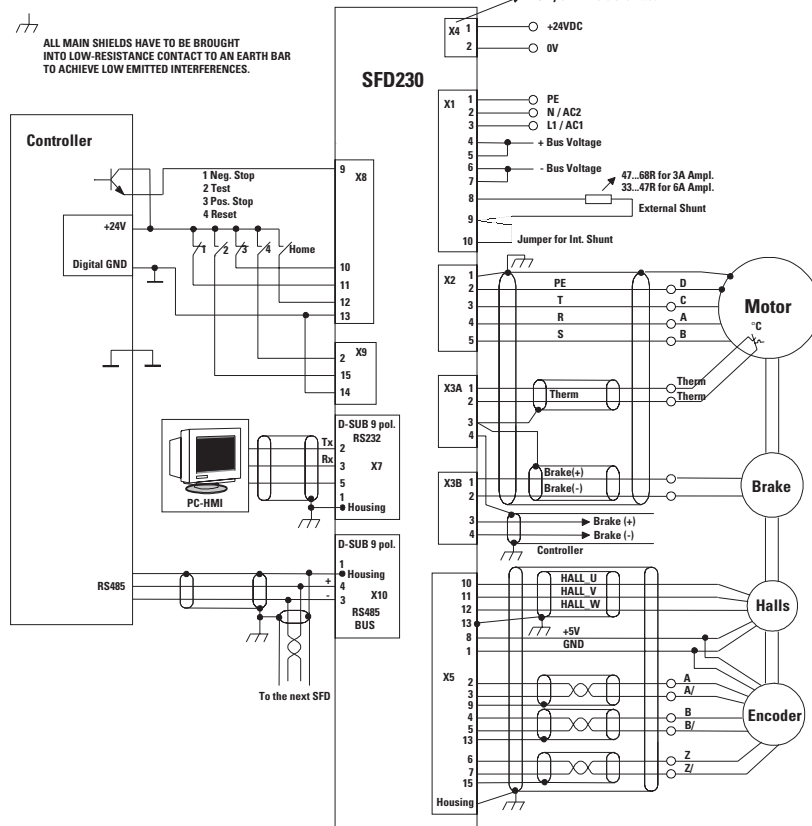



P W M

Servo Digital Drive Amplifier Ordering Chart

Ordering Chart

Example: SFD230/3HRT

SFD230/	3	H	R	T
Digital Drive	Output Amps	Logic Supply Voltage	Feedback	Digital Input Type
SFD 230 Volt Digital Drive	3=3 amp	H=Intermediate Bus (user supplied)	R=Resolver	T=5Volt/TTL Digital Input
	6=6 amp	L=24 V External Supply	I=Encoder	Blank=Standard Digital Input (12-30V)