

**1000/2000 Series
POWERBLOK® MODULE**

Features

- A universal servo-drive integrated on a Power Hybrid Module.
- Designed for direct PWM Servo Control
- Designed for use with Deta Tau's PMAC controllers and other digital controllers.
- Focused on the demanding needs of design engineers in OEM and systems integration applications.
- All inputs are optically isolated.
- An optically isolated Gate Drive buffer array, translates the PWM commands into appropriately scaled IGBT drive signals to produce the PWM power waveforms required.
- High fidelity current feedback. This synchronized current feedback and control is one of the keys to the superior servo performance possible with an all digital PowerBlok® system.
- Choice of OEMs and system integrators requiring the flexibility to independently optimize the drive, heat sink and power supply, based on their specific needs.

Command Interface Features

- Optically isolated PWM commands
- Adjustable PWM frequency to 10 kHz
- Dead Time logic to prevent IGBT shoot-through
- Digital Serial A/D motor current feedback
- 7 - segment fault /status display

Protection Features

- Short circuit and ground fault
- Instantaneous over-current protection
- Over-voltage, under-voltage protection
- Base plate over temperature
- PWM frequency fault
- Serial fault status feedback

Specifications

- AC Line Input Frequency:
47 to 66 Hz
- Line Impedance:
1% to 5%
- Voltages:
120 V, 120/240 V, 200/240 V, 380/480 V
- Capacitance Required:
Standard and High Capacitance CapBlok® available
- Operating Temperature:
0 - 70° C - module with sufficient heat sink
0 - 40° C - (50° C, 1-3 Hp) - assembled drive configurations
- Storage Temperature:
-20 - 100° C
- Max Substrate Temperature:
90° C
- Relative Humidity:
0 - 95% Non-condensing
- Altitude:
1000m (3300 ft.) Max.
De-rating 2 % for every 330 m (1000ft)
- Vibration:
IEC68-2
- Efficiency:
97% 6 - 21.5 kw Ratings
95% 0.8 - 3.8 kw Ratings
- Power Ratings:
0.8 to 2.1 kw at 120 Vac
1 to 11.2 kw at 230 Vac
1 to 21.5 kw at 460 Vac
- Fan Output, Max Allowable current:
Series 1000, Start 600 mA, Run 300 mA
Series 2000, Start 1.2 A, Run 800 mA
- Max allowable PWM:
10 kHz, PWM frequencies over 5 kHz may require derating

PowerBlok® Technical Specifications

1000 Series

PowerBlok Module Type Number	1001C	1002C	1003C	1001D	1002D	1003D	1005D	1001E	1002E	1003E	1005E	
PDM												
AC Line Input Voltage	VAC 120V±10%			200/240V±10%				380/480V±10%				
Cont. Output Cur.(RMS)	Arms	4.0	7.2	10.4	3.6	6.8	9.6	15.2	1.8	3.4	4.8	7.6
Peak Output Cur.(RMS)	Arms	8.0	14.4	20.8	6.8	13.6	19.2	30.4	3.6	6.8	9.6	15.2

2000 Series

PowerBlok Module Type Number	2007D	2010D	2007E	2010E	2015E	2020E	
PDM							
AC Line Input Voltage	VAC 200/240V±10%			380/480V±10%			
Cont. Output Cur.(RMS)	Arms	22	28	11	14	21	27
Peak Output Cur.(RMS)	Arms	44	56	22	28	31.5	35

Connection Diagram

*Showing only 1 axis

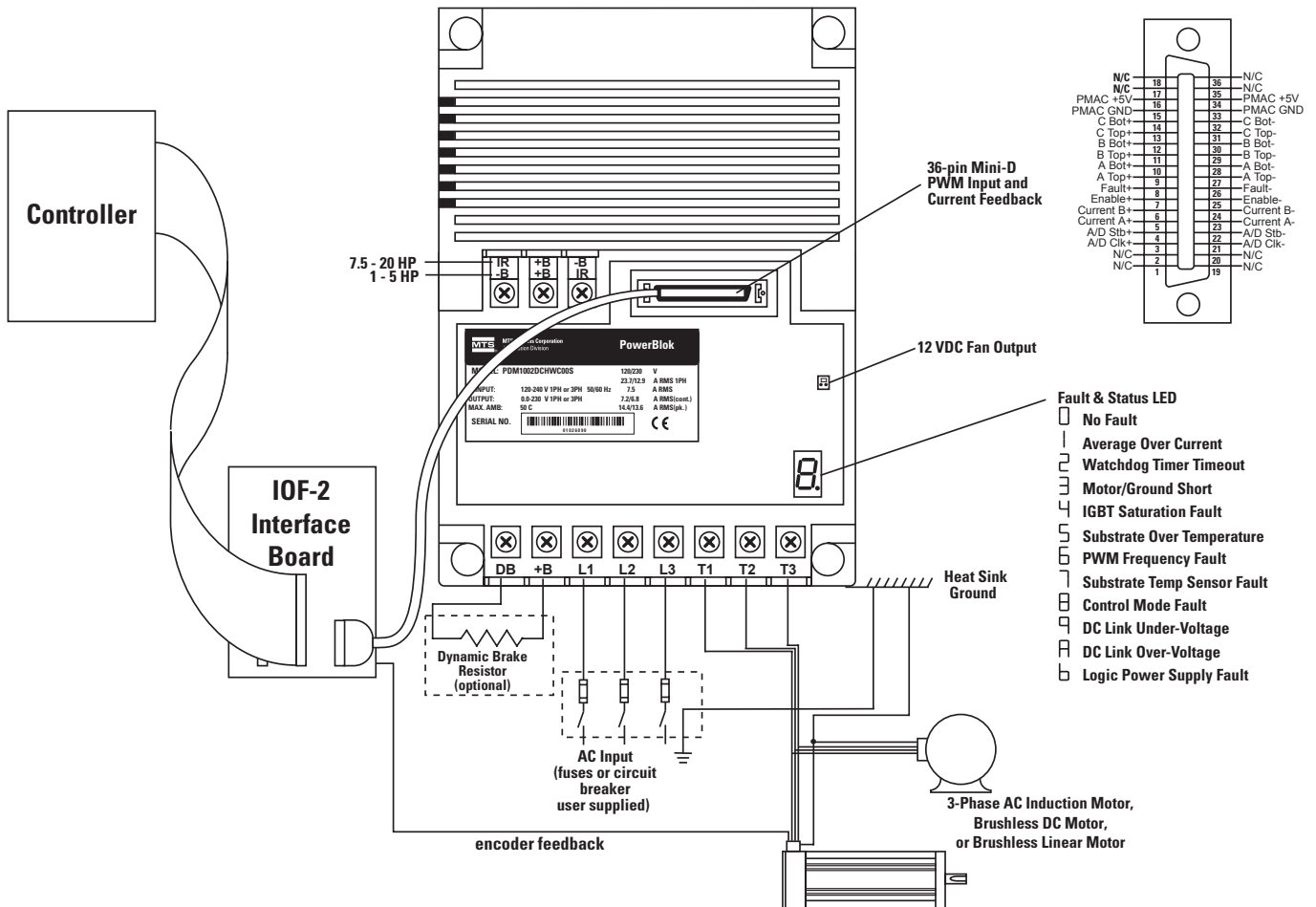

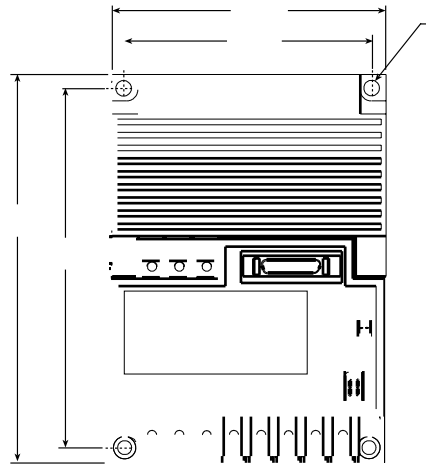

Wall Mount Dimensions

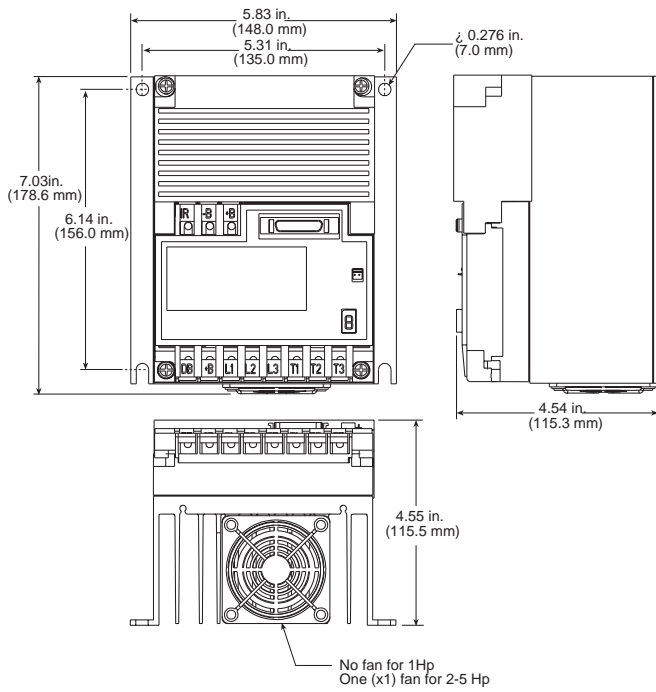

Bookend Dimensions

* Available upon request

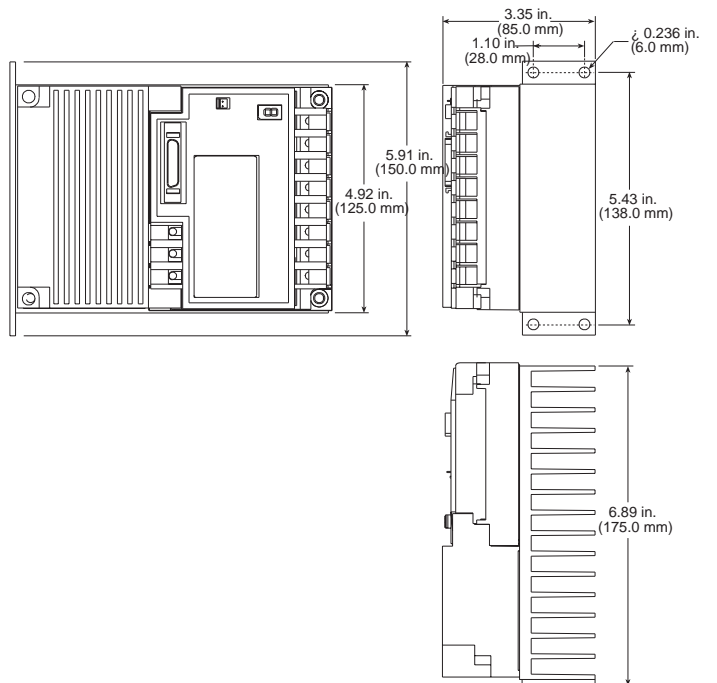

Module Dimensions

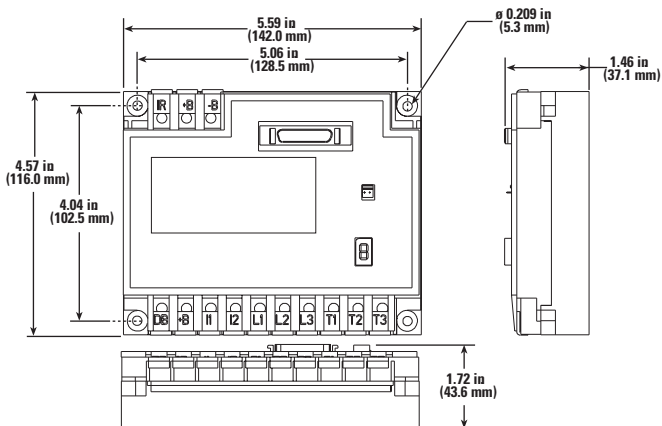

Module (7.5-10 Hp) Dimensions with CapBlok®

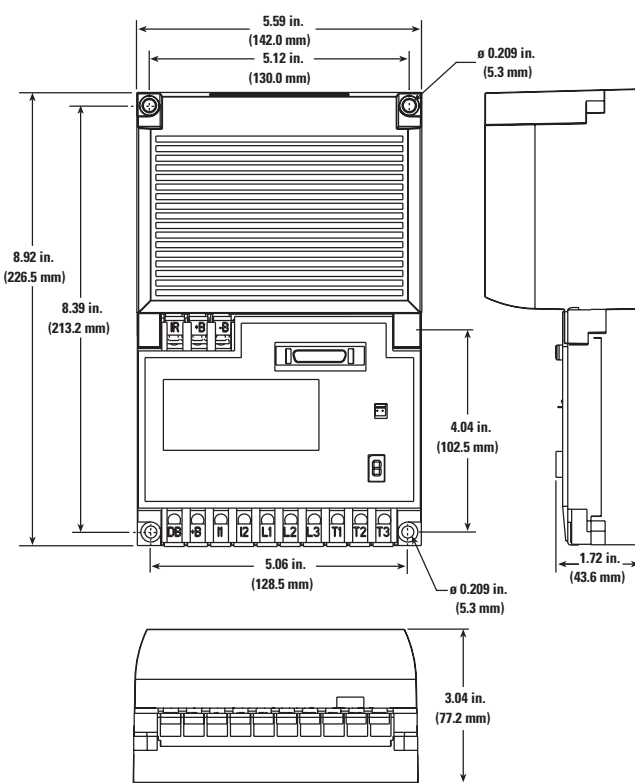

Module (7.5-10 Hp) Dimensions with CapBlok® and Heat Sink

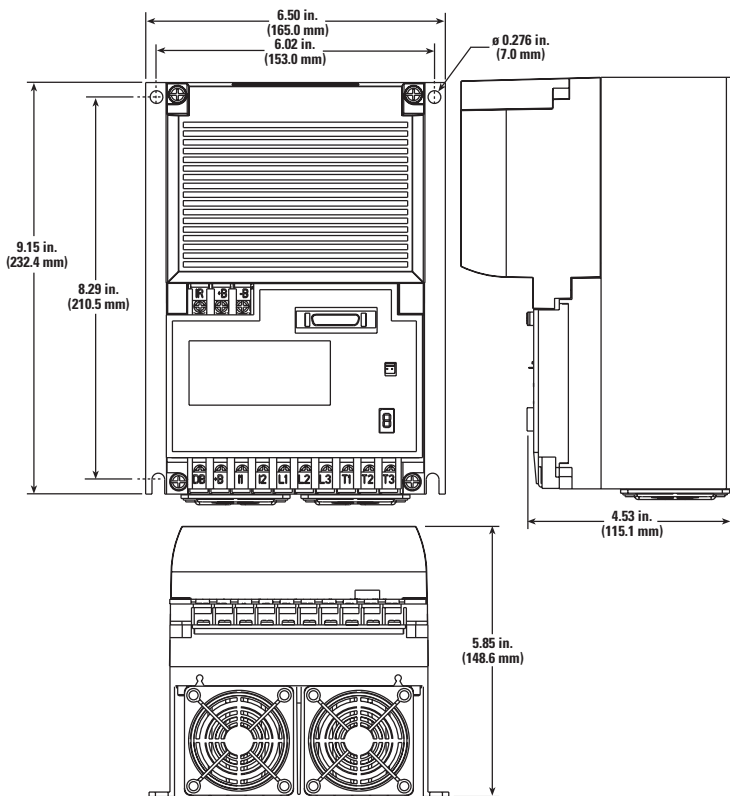

Module (15-20 Hp) Dimensions with CapBlok®

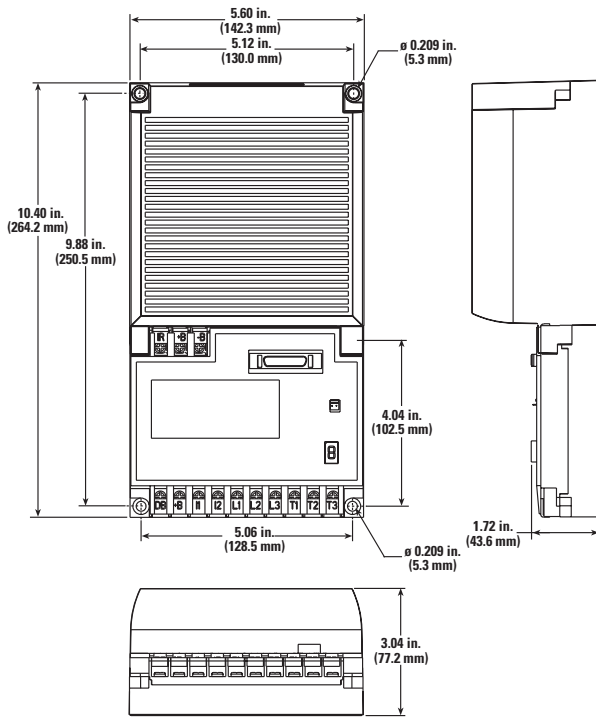

Module (15-20 Hp) Dimensions with CapBlok® and Heat Sink

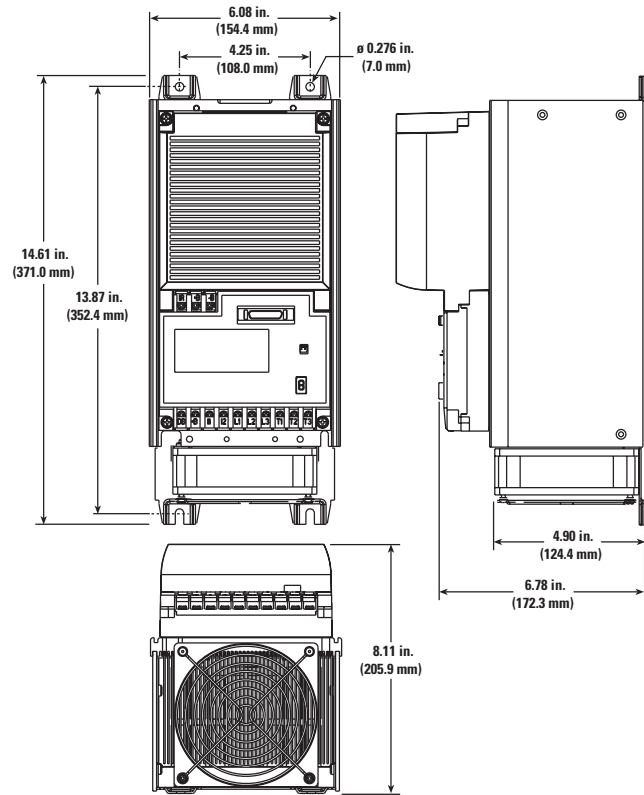

PowerBlok Components & Accessories

120 VAC CapBlocs

CS-1-C	0.5 Hp	CapBlok Module	120 VAC	2800 µF	50/60 Hz
CS-2-C	1.0 Hp	CapBlok Module	120 VAC	4200 µF	50/60 Hz
CS-3-C	1.5 Hp	CapBlok Module	120 VAC	4200 µF	50/60 Hz

230 VAC CapBlocs

CS-1-D	1 Hp	CapBlok Module	200-240 VAC	540 µF	50/60 Hz
CS-2-D	2 Hp	CapBlok Module	200-240 VAC	1080 µF	50/60 Hz
CS-3-D	3 Hp	CapBlok Module	200-240 VAC	1080 µF	50/60 Hz
CS-5-D	5 Hp	CapBlok Module	200-240 VAC	1620 µF	50/60 Hz
CS-7-D	7 Hp	CapBlok Module	200-240 VAC	3000 µF	50/60 Hz
CS-10-D	10 Hp	CapBlok Module	200-240 VAC	3000 µF	50/60 Hz

460 VAC CapBlocs

CS-1-E	1 Hp	CapBlok Module	380-480 VAC	135 µF	50/60 Hz
CS-2-E	2 Hp	CapBlok Module	380-480 VAC	270 µF	50/60 Hz
CS-3-E	3 Hp	CapBlok Module	380-480 VAC	270 µF	50/60 Hz
CS-5-E	5 Hp	CapBlok Module	380-480 VAC	405 µF	50/60 Hz
CS-7-E	7 Hp	CapBlok Module	380-480 VAC	750 µF	50/60 Hz
CS-10-E	10 Hp	CapBlok Module	380-480 VAC	750 µF	50/60 Hz
CS-15-E	15 Hp	CapBlok Module	380-480 VAC	1350 µF	50/60 Hz
CS-20-E	20 Hp	CapBlok Module	380-480 VAC	1350 µF	50/60 Hz

*Mounting hardware is not included within the CapBlok ship kit, but may be ordered separately.

Miscellaneous Accessories

Part Number	Description
IOF-2	Digital Interface Board - Panel mount, terminal connectors for encoder feedback.
IOF-2-DR	Digital Interface Board - Din rail mount, terminal connectors for encoder feedback.
IOF-2-DB	Digital Interface Board - Panel mount, 15 pin D connectors for encoder feedback.
IOF-2-DR-DB	Digital Interface Board - Din rail mount, 15 pin D connectors for encoder feedback.
MK10	Mount Kit - Contains the mounting screws and "Thermastrate" thermal mounting pads for 10 1000 Series Blok and CapBlok assemblies.
MK20	Mount Kit - Contains the mounting screws and "Thermastrate" thermal mounting pads for 10 2000 Series Blok and CapBlok assemblies.
DBRXX-XXXX	Dynamic Brake Resistor - Consult Dynamic Brake Resistor Data Sheet for standard available sizes. For non-standard ratings - consult factory.

Ordering Chart

Example: PDM1005ECSWC00S

PDM	10	05	E	CS	WC	00S
CONTROL TYPE	SIZE	RATING*	VOLTAGE	CAPACITANCE	HEAT SINK	CONFIGURATION
PDM = PowerBlok	10 - 1000 Series	01	C = 120 V	CS = Standard	BB = Bookshelf 1 Hp	00S = Standard
	20 - 2000 Series	02	D = 200/240 V	CH = High, rated for single-phase inputs on 1 and 2 Hp Drive Modules	WC = Wall Mount 1-5 Hp	XXX = Special
		03	E = 380/460 V		WE = Wall Mount 7.5-10 Hp	
		05			WG = Wall Mount 15-20 Hp	
		07				
		10				
		15				
		20				

* See technical specifications