



460 Series
VOLT AMPLIFIER

MPA-460
200-520 VAC
45-65Hz

Amplifier Current Sizes

Model	Continuous Output Current	Peak Output Current*	PWM Frequency	1 ϕ Line Current**	3 ϕ Line Current**	Weight
MPA-05	5 amps	10 amps	15KHz	8 amps	4 amps	22.6 lbs.[10.2Kg]
MPA-09	9 amps	18 amps	15KHz	10 amps	7 amps	23.2 lbs.[10.6Kg]
MPA-15	15 amps	30 amps	15KHz	18 amps	11 amps	24.8 lbs.[11.3Kg]
MPA-25	25 amps	50 amps	12KHz	30 amps	18 amps	28.4 lbs.[12.9Kg]
MPA-35	35 amps	70 amps	12KHz	42 amps	25 amps	31.0 lbs.[14.1Kg]
MPA-50	50 amps	100 amps	10KHz	60 amps	35 amps	38.6 lbs.[17.5Kg]
MPA-75	75 amps	120 amps	10KHz	N/A	55 amps	56.0 lbs.[25.4Kg]
MPA-100	100 amps	165 amps	10KHz	N/A	70 amps	68.4 lbs.[31.1Kg]

*Peak Current \geq 1 second.

**Continuous Maximum Current

Wiring Diagram

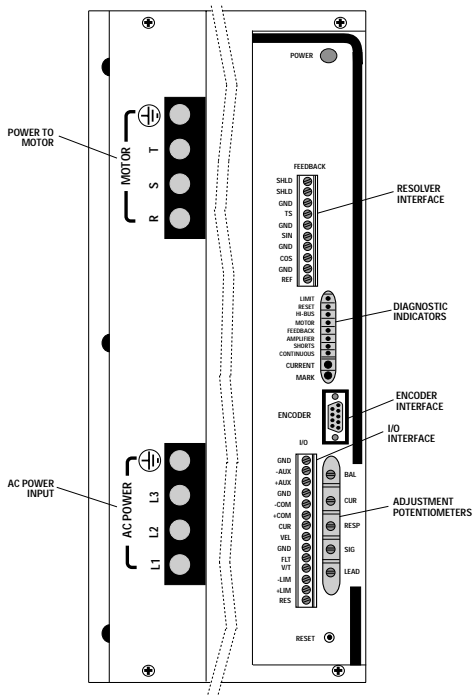

Connection Diagram

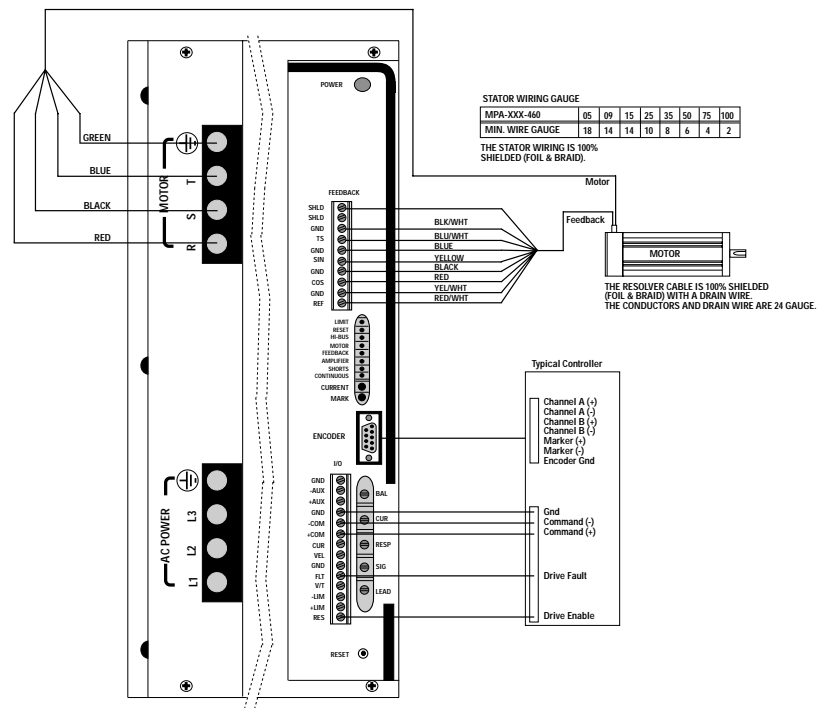

Mechanical Footprints

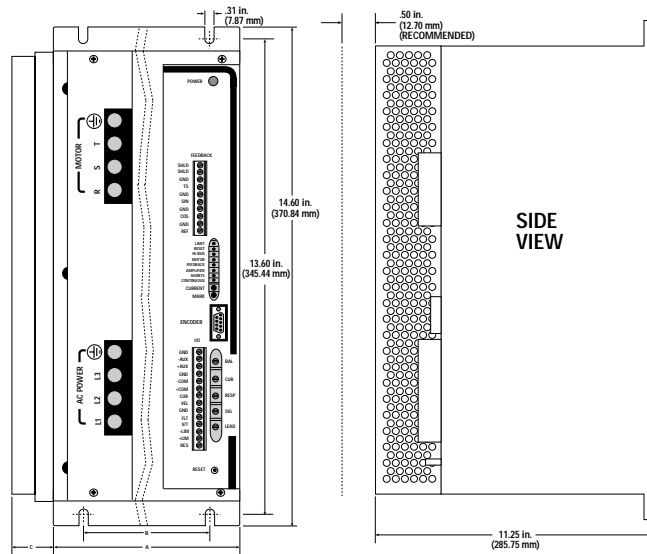

MPA-460 Amplifier Dimensions

Model	A in.[mm]	B in.[mm]	C in.[mm]
MPA-05/09/15-460	6.50[165.10]	4.50[114.30]	0.53[13.46]
MPA-25/35-460	8.50[215.90]	6.50[165.10]	0.53[13.46]
MPA-50-460	8.50[215.90]	6.50[165.10]	2.30[58.42]

Note: Dimensions are to be used for reference purposes only.

MPA-75/100-460

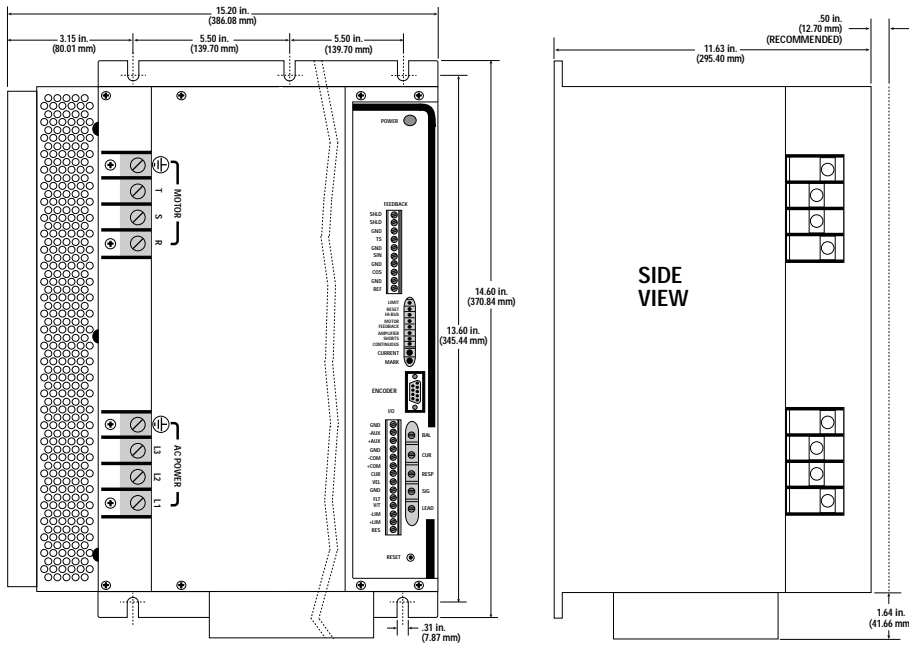

Note: Dimensions are to be used for reference purposes only.