

**TORQUE RANGE: 5.8-18.8 IN-LBS**
**.66-2.12 Nm**
**Motor Data (Sine)**

Motor Parameters		Units	721ASF****	721BSG****	721CSG****	722ASF****	722BSG****	722CSG****
Horsepower	Hp Rated	Hp	0.41	0.41	0.24	0.74	0.74	0.47
Kilowatts	KW Rated	KW	0.31	0.31	0.18	0.55	0.55	0.35
Max. Operating Speed	N Max	RPM	6800	6800	4000	7000	7000	4000
Speed @ Rated Torque	N Rated	RPM	5500	5500	3000	5000	5000	3000
*Continuous Rated Torque @ Rated Speed		IN-LBS[Nm]	4.7[0.54]	4.7[0.54]	5.1[0.58]	9.4[1.06]	9.4[1.06]	10.0[1.13]
*Continuous Stall Torque		IN-LBS[Nm]	5.8[0.66]	5.8[0.66]	5.8[0.66]	11.3[1.28]	11.3[1.28]	11.3[1.28]
Continuous Line Current		AMPS(RMS/φ)	2.7	1.4	0.7	5.0	2.7	1.4
Peak Torque	Tpk	IN-LBS[Nm]	17.0[2.0]	17.0[2.0]	17.0[2.0]	34.0[3.8]	34.0[3.8]	34.0[3.8]
Peak Current		AMPS(RMS/φ)	8.1	4.2	2.1	15.0	8.2	4.2
Max. Theoretical Accel.		RAD/SEC <sup>2</sup>	110,000	110,000	110,000	130,000	130,000	130,000
Torque Sensitivity	Kt	IN-LBS/AMP(RMS/φ)[Nm/AMP(RMS/φ)]	2.14[0.241]	4.12[0.465]	8.10[0.916]	2.26[0.255]	4.12[0.465]	8.12[0.917]
Back EMF (Line to Line)	±10%	Vrms/Krpm	13.4	25.9	51.0	14.2	25.9	51.1
D.C. Resistance (P-P)	±10%	OHMS	3.1	11	45	1.1	3.7	15
Inductance (P-P)	±10%	MILLIHENRIES	4.9	17	70	2.3	7.3	29
Rotor Inertia	Jm	IN-LBS-SEC <sup>2</sup> [Kg-M <sup>2</sup> ]	.00015[.000017]	.00015[.000017]	.00015[.000017]	.00027[.000031]	.00027[.000031]	.00027[.000031]
Static Friction	Tf	IN-LBS[Nm]	0.6[0.07]	0.6[0.07]	0.6[0.07]	0.8[0.09]	0.8[0.09]	0.8[0.09]
Motor Weight		LBS[Kg]	3.5[1.59]	3.5[1.59]	3.5[1.59]	4.4[2.00]	4.4[2.00]	4.4[2.00]
Line Voltage		VAC	110	230	230	110	230	230

Motor Parameters		Units	723ASF****	723BSG****	723CSG****	724ASF****	724BSG****	724CSG****
Horsepower	Hp Rated	Hp	0.91	0.91	0.63	1.3	1.3	0.79
Kilowatts	KW Rated	KW	0.68	0.68	0.47	0.93	0.93	0.58
Max. Operating Speed	N Max	RPM	6300	6300	4000	6000	6000	4000
Speed @ Rated Torque	N Rated	RPM	4500	4500	3000	5000	5000	3000
*Continuous Rated Torque @ Rated Speed		IN-LBS[Nm]	12.8[1.44]	12.8[1.44]	13.3[1.50]	15.8[1.79]	15.8[1.79]	16.6[1.88]
*Continuous Stall Torque		IN-LBS[Nm]	15.0[1.69]	15.0[1.69]	15.0[1.69]	18.8[2.12]	18.8[2.12]	18.8[2.12]
Continuous Line Current		AMPS(RMS/φ)	6.9	3.6	1.8	8.9	4.4	2.3
Peak Torque	Tpk	IN-LBS[Nm]	45.0[5.1]	45.0[5.1]	45.0[5.1]	56.0[6.4]	56.0[6.4]	56.0[6.4]
Peak Current		AMPS(RMS/φ)	20.7	10.8	5.5	26.8	13.2	6.9
Max. Theoretical Accel.		RAD/SEC <sup>2</sup>	120,000	120,000	120,000	110,000	110,000	110,000
Torque Sensitivity	Kt	IN-LBS/AMP(RMS/φ)[Nm/AMP(RMS/φ)]	2.17[0.245]	4.18[0.472]	8.17[0.923]	2.10[0.237]	4.26[0.481]	8.23[0.930]
Back EMF (Line to Line)	±10%	Vrms/Krpm	13.7	26.3	51.4	13.2	26.8	51.8
D.C. Resistance (P-P)	±10%	OHMS	0.58	2.2	7.8	0.39	1.5	5.5
Inductance (P-P)	±10%	MILLIHENRIES	1.3	4.9	18	0.9	3.6	13
Rotor Inertia	Jm	IN-LBS-SEC <sup>2</sup> [Kg-M <sup>2</sup> ]	.00038[.000043]	.00038[.000043]	.00038[.000043]	.00049[.000055]	.00049[.000055]	.00049[.000055]
Static Friction	Tf	IN-LBS[Nm]	1.0[0.11]	1.0[0.11]	1.0[0.11]	1.2[0.14]	1.2[0.14]	1.2[0.14]
Motor Weight		LBS[Kg]	5.3[2.40]	5.3[2.40]	5.3[2.40]	6.2[2.81]	6.2[2.81]	6.2[2.81]
Line Voltage		VAC	110	230	230	110	230	230

**Brake Info:**

Min. Holding Torque: 24 IN-LBS  
 Input Voltage: 24VDC  
 Current: .6 AMPS  
 Inertia: .00007 IN-LB-SEC<sup>2</sup>  
 Weight Adder: 1.0 LB

\*25° C Ambient with a maximum case temperature of 85° C on motor. Motor mounted on a 12" x 12" x 1/2" aluminum heatsink. Thermostat in stator windings will open if winding temperature exceeds 155° C for an approximate +10% headroom in the continuous torque rating before thermostat opens.

**Mechanical Notes:**

1. Axial Load: 20 LBS. Max.
2. Radial Load: 35 LBS. Max. @ 1" from face
3. Motor sealed to IP65

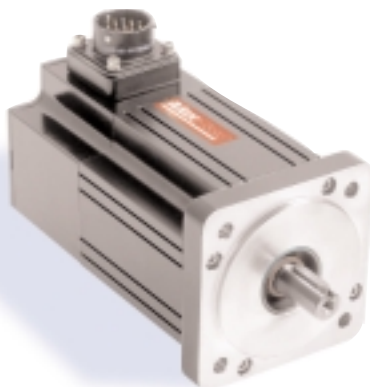
**TORQUE RANGE: 5.8-18.8 IN-LBS**
**.66-2.12 Nm**
**Motor Data (Trap)**

Motor Parameters		Units	721ATF****	721BTG****	721CTG****	722ATF****	722BTG****	722CTG****
Horsepower	Hp Rated	Hp	0.41	0.41	0.24	0.74	0.74	0.47
Kilowatts	KW Rated	KW	0.31	0.31	0.18	0.55	0.55	0.35
Max. Operating Speed	N Max	RPM	6800	6800	4000	7000	7000	4000
Speed @ Rated Torque	N Rated	RPM	5500	5500	3000	5000	5000	3000
*Continuous Rated Torque @ Rated Speed		IN-LBS[Nm]	4.7[0.54]	4.7[0.54]	5.1[0.58]	9.4[1.06]	9.4[1.06]	10.0[1.13]
*Continuous Stall Torque		IN-LBS[Nm]	5.8[0.66]	5.8[0.66]	5.8[0.66]	11.3[1.28]	11.3[1.28]	11.3[1.28]
Continuous Line Current		AMPS	3.8	2.0	1.0	7.1	3.9	2.0
Peak Torque	Tpk	IN-LBS[Nm]	17.0[2.0]	17.0[2.0]	17.0[2.0]	34.0[3.8]	34.0[3.8]	34.0[3.8]
Peak Current		AMPS	12.0	6.0	3.0	21.0	12.0	5.9
Max. Theoretical Accel.		RAD/SEC <sup>2</sup>	110,000	110,000	110,000	130,000	130,000	130,000
Torque Sensitivity	Kt	IN-LBS/AMP[Nm/AMP]	1.51[0.171]	2.91[0.329]	5.73[0.647]	1.60[0.180]	2.91[0.329]	5.74[0.649]
Back EMF (Line to Line)	±10%	Vrms/Krpm	13.4	25.9	51.0	14.2	25.9	51.1
D.C. Resistance (P-P)	±10%	OHMS	3.1	11	45	1.1	3.7	15
Inductance (P-P)	±10%	MILLIHENRIES	4.9	17	70	2.3	7.3	29
Rotor Inertia	Jm	IN-LBS-SEC <sup>2</sup> [Kg-M <sup>2</sup> ]	.00015[.000017]	.00015[.000017]	.00015[.000017]	.00027[.000031]	.00027[.000031]	.00027[.000031]
Static Friction	Tf	IN-LBS[Nm]	0.6[0.007]	0.6[0.007]	0.6[0.007]	0.8[0.09]	0.8[0.09]	0.8[0.09]
Motor Weight		LBS[Kg]	3.5[1.59]	3.5[1.59]	3.5[1.59]	4.4[2.00]	4.4[2.00]	4.4[2.00]
Line Voltage		VAC	110	230	230	110	230	230

Motor Parameters		Units	723ATF****	723BTG****	723CTG****	724ATF****	724BTG****	724CTG****
Horsepower	Hp Rated	Hp	0.91	0.91	0.63	1.3	1.3	0.79
Kilowatts	KW Rated	KW	0.68	0.68	0.47	0.93	0.93	0.58
Max. Operating Speed	N Max	RPM	6300	6300	4000	6000	6000	4000
Speed @ Rated Torque	N Rated	RPM	4500	4500	3000	5000	5000	3000
*Continuous Rated Torque @ Rated Speed		IN-LBS[Nm]	12.8[1.44]	12.8[1.44]	13.3[1.50]	15.8[1.79]	15.8[1.79]	16.6[1.88]
*Continuous Stall Torque		IN-LBS[Nm]	15.0[1.69]	15.0[1.69]	15.0[1.69]	18.8[2.12]	18.8[2.12]	18.8[2.12]
Continuous Line Current		AMPS	9.8	5.1	2.6	13.0	6.2	3.2
Peak Torque	Tpk	IN-LBS[Nm]	45.0[5.1]	45.0[5.1]	45.0[5.1]	56.0[6.4]	56.0[6.4]	56.0[6.4]
Peak Current		AMPS	29.0	15.0	7.8	38.0	19.0	9.7
Max. Theoretical Accel.		RAD/SEC <sup>2</sup>	120,000	120,000	120,000	110,000	110,000	110,000
Torque Sensitivity	Kt	IN-LBS/AMP[Nm/AMP]	1.53[0.173]	2.96[0.334]	5.78[0.652]	1.49[0.168]	3.01[0.340]	5.82[0.658]
Back EMF (Line to Line)	±10%	Vrms/Krpm	13.7	26.3	51.4	13.2	26.8	51.8
D.C. Resistance (P-P)	±10%	OHMS	0.58	2.2	7.8	0.39	1.5	5.5
Inductance (P-P)	±10%	MILLIHENRIES	1.3	4.9	18	0.9	3.6	13
Rotor Inertia	Jm	IN-LBS-SEC <sup>2</sup> [Kg-M <sup>2</sup> ]	.00038[.000043]	.00038[.000043]	.00038[.000043]	.00049[.000055]	.00049[.000055]	.00049[.000055]
Static Friction	Tf	IN-LBS[Nm]	1.0[0.11]	1.0[0.11]	1.0[0.11]	1.2[0.14]	1.2[0.14]	1.2[0.14]
Motor Weight		LBS[Kg]	5.3[2.40]	5.3[2.40]	5.3[2.40]	6.2[2.81]	6.2[2.81]	6.2[2.81]
Line Voltage		VAC	110	230	230	110	230	230

**Brake Info:**

Min. Holding Torque: 24 IN-LBS  
 Input Voltage: 24VDC  
 Current: .6 AMPS  
 Inertia: .00007 IN-LB-SEC<sup>2</sup>  
 Weight Adder: 1.0 LB

\*25° C Ambient with a maximum case temperature of 85° C on motor. Motor mounted on a 12" x 12" x 1/2" aluminum heatsink. Thermostat in stator windings will open if winding temperature exceeds 155° C for an approximate +10% headroom in the continuous torque rating before thermostat opens.

**Mechanical Notes:**

1. Axial Load: 20 LBS. Max.
2. Radial Load: 35 LBS. Max. @ 1" from face
3. Motor sealed to IP65

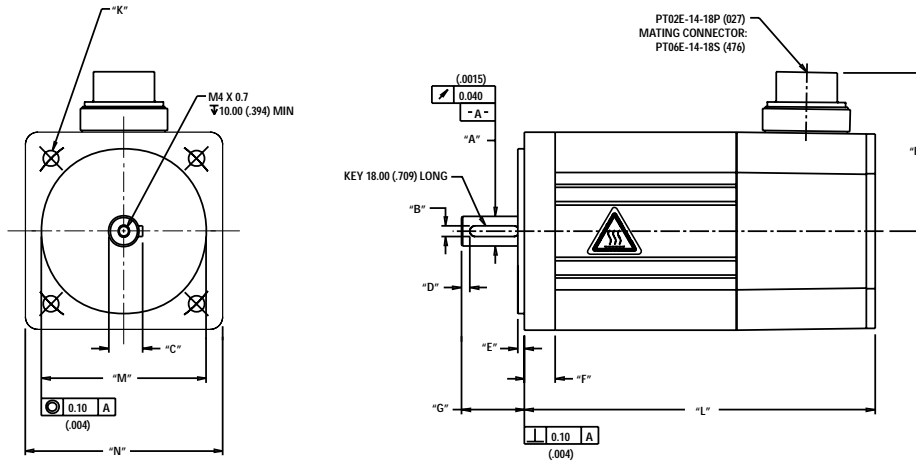

## 2 3/4" (72) Metric Connectorized Termination-Option 1 Motors

Model	"A"	"B"	"C"	"D"	"E"	"F"	"G"
MPM721***7*1*	∅ 11.012 (.4335) 11.001 (.4331)	3.988 (.1570) 3.958 (.1558)	12.42 (.489)	3.00 (.118)	2.5 (.10)	11.2 (.44)	23.0 (.91) 22.5 (.89)
MPM722***7*1*	∅ 11.012 (.4335) 11.001 (.4331)	3.988 (.1570) 3.958 (.1558)	12.42 (.489)	3.00 (.118)	2.5 (.10)	11.2 (.44)	23.0 (.91) 22.5 (.89)
MPM723***7*1*	∅ 11.012 (.4335) 11.001 (.4331)	3.988 (.1570) 3.958 (.1558)	12.42 (.489)	3.00 (.118)	2.5 (.10)	11.2 (.44)	23.0 (.91) 22.5 (.89)
MPM724***7*1*	∅ 11.012 (.4335) 11.001 (.4331)	3.988 (.1570) 3.958 (.1558)	12.42 (.489)	3.00 (.118)	2.5 (.10)	11.2 (.44)	23.0 (.91) 22.5 (.89)

Model	"H"	"K"	"L"	"L" w/ Brake	"M"	"N"
MPM721***7*1*	58 (2.3) Max	∅5.79 (.228) THRU (4) EQ SPD AS SHOWN ON ∅75.01 (2.953) B.C.	128.1 (5.05) Max	166.3 (6.55) Max	∅ 60.012 (2.3627) 59.993 (2.3619)	□ 72.0 (2.84)
MPM722***7*1*	58 (2.3) Max	∅5.79 (.228) THRU (4) EQ SPD AS SHOWN ON ∅75.01 (2.953) B.C.	147.3 (5.80) Max	185.4 (7.30) Max	∅ 60.012 (2.3627) 59.993 (2.3619)	□ 72.0 (2.84)
MPM723***7*1*	58 (2.3) Max	∅5.79 (.228) THRU (4) EQ SPD AS SHOWN ON ∅75.01 (2.953) B.C.	166.4 (6.55) Max	204.5 (8.05) Max	∅ 60.012 (2.3627) 59.993 (2.3619)	□ 72.0 (2.84)
MPM724***7*1*	58 (2.3) Max	∅5.79 (.228) THRU (4) EQ SPD AS SHOWN ON ∅75.01 (2.953) B.C.	185.4 (7.30) Max	223.5 (8.80) Max	∅ 60.012 (2.3627) 59.993 (2.3619)	□ 72.0 (2.84)

Metric = 7

Option 6 Mount-Not Available

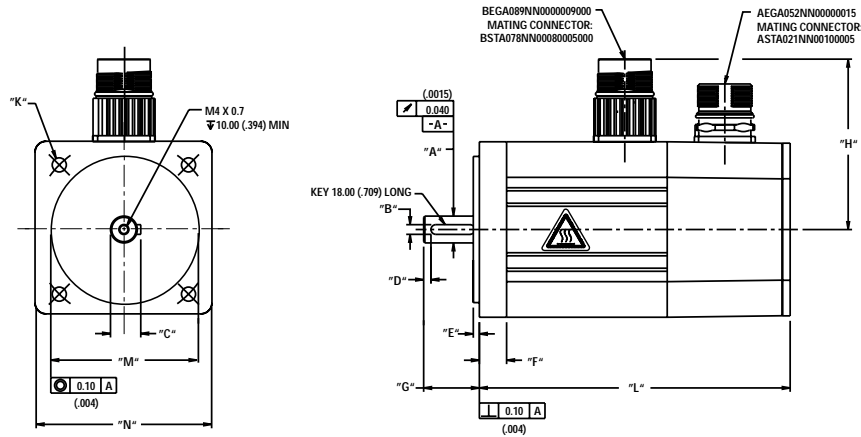

**2 3/4" (72) Metric Intercon Termination-Option 2 Motors**

Model	"A"	"B"	"C"	"D"	"E"	"F"	"G"
MPM721***7*2*	11.012 (.4335) 11.001 (.4331)	3.988 (.1570) 3.958 (.1558)	12.42 (.489)	3.00 (.118)	2.5 (.10)	11.2 (.44)	23.0 (.91) 22.5 (.89)
MPM722***7*2*	11.012 (.4335) 11.001 (.4331)	3.988 (.1570) 3.958 (.1558)	12.42 (.489)	3.00 (.118)	2.5 (.10)	11.2 (.44)	23.0 (.91) 22.5 (.89)
MPM723***7*2*	11.012 (.4335) 11.001 (.4331)	3.988 (.1570) 3.958 (.1558)	12.42 (.489)	3.00 (.118)	2.5 (.10)	11.2 (.44)	23.0 (.91) 22.5 (.89)
MPM724***7*2*	11.012 (.4335) 11.001 (.4331)	3.988 (.1570) 3.958 (.1558)	12.42 (.489)	3.00 (.118)	2.5 (.10)	11.2 (.44)	23.0 (.91) 22.5 (.89)



Model	"H"	"K"	"L"	"L" w/ Brake	"M"	"N"
MPM721***7*2*	70 (2.8) Max	Ø5.79 (.228) THRU (4) EQ SPD AS SHOWN ON Ø75.01 (2.953) B.C.	128.1 (5.05) Max	166.4 (6.55)	Ø 60.012 (2.3627) 59.993 (2.3619)	□ 72.0 (2.84)
MPM722***7*2*	70 (2.8) Max	Ø5.79 (.228) THRU (4) EQ SPD AS SHOWN ON Ø75.01 (2.953) B.C.	147.3 (5.80) Max	185.4 (7.30)	Ø 60.012 (2.3627) 59.993 (2.3619)	□ 72.0 (2.84)
MPM723***7*2*	70 (2.8) Max	Ø5.79 (.228) THRU (4) EQ SPD AS SHOWN ON Ø75.01 (2.953) B.C.	166.4 (6.55) Max	204.5 (8.05)	Ø 60.012 (2.3627) 59.993 (2.3619)	□ 72.0 (2.84)
MPM724***7*2*	70 (2.8) Max	Ø5.79 (.228) THRU (4) EQ SPD AS SHOWN ON Ø75.01 (2.953) B.C.	185.4 (7.30) Max	223.5 (8.80)	Ø 60.012 (2.3627) 59.993 (2.3619)	□ 72.0 (2.84)

Metric = 7  
Option 6 Mount-Not Available

## 2 3/4" Motor with Resolver Feedback

### Option 1

**Motor Therm Resolver Connector 270-00024 (PT02E-14-18P (027))**



Pin	Function	Wire Color
A	$\phi$ R	RED
B	$\phi$ S	BLACK
C	$\phi$ T	BLUE
D	PE GND	GRN/YEL
U	THERM	WHITE
N	THERM	WHITE
H	SIN	YELLOW
G	COS GND	BLACK
S	COS	RED
F	SIN GND	BLUE
R	REF GND	YEL/WHT
E	REF	RED/WHT
J	RES SHLD	GRN/YEL
*K	BRK (+) 	DIODE
*L	BRK (-) 	1N4007
*M	BRK SHLD	-
P	-	-
T	-	-

\* USE ONLY WITH BRAKE OPTION

### Option 3-Not Available

### Option 2

**Motor Therm Connector 270-000256 (BEGA089NN000009000)**

Pin	Function	Wire Color
1	$\phi$ R (U1)	RED
2	PE GND	GRN/YEL
3	$\phi$ T (W1)	BLUE
4	$\phi$ S (V1)	BLACK
*A	BRK (+) 	DIODE
*B	BRK (-) 	1N4007
C	THERM	BLACK
D	THERM	BLACK

\* USE ONLY WITH BRAKE OPTION

**Resolver Connector 270-00257 (AEGA052NN00000013000)**

Pin	Function	Wire Color
1	-	-
2	REF (R1)	RED/WHT
3	REF GND (R2)	YEL/WHT
4	COS GND (S1)	BLACK
5	COS (S3)	RED
6	SIN (S2)	YELLOW
7	SIN GND (S4)	BLUE
8	-	-
9	-	-
10	-	-
11	-	-
12	-	-

## 2 3/4" Motor with Encoder Feedback

### Option 1

#### Motor Encoder Therm Connector 270-00219 (PT02E-16-23P(027))



Pin	Function	Wire Color
A	$\phi$ R	RED
B	$\phi$ S	BLACK
C	$\phi$ T	BLUE
D	PE GND	GRN/YEL
T	GROUND	BLACK
E	+5VDC	RED
F	CH A	BLUE
U	CH A\	BLUE/BLK
G	CH B	GREEN
V	CH B\	GRN/BLK
H	CH Z	YELLOW
W	CH Z\	YEL/BLK
J	CH U	BROWN
K	CH U\	BRN/BLK
X	CH V	GRAY
L	CH V\	GRAY/BLK
Y	CH W	WHITE
M	CH W\	WHT/BLK
N	GND/CABLE	SHLD
S	THERM	BLACK
R	THERM	BLACK
*P	BRK (+) 	DIODE
*Z	BRK (-) 	1N4007

\* USE ONLY WITH BRAKE OPTION

### Option 3-Not Available

### Option 2

#### Motor Therm Connector 270-000256 (BEGA089NN000009000)

Pin	Function	Wire Color
1	$\phi$ R (U1)	RED
2	PE GND	GRN/YEL
3	$\phi$ S (W1)	BLACK
4	$\phi$ T (V1)	BLUE
*A	BRK (+) 	DIODE
*B	BRK (-) 	1N4007
C	THERM	BLACK
D	THERM	BLACK

\* USE ONLY WITH BRAKE OPTION

#### Encoder Connector 270-00257 (AEGA052NN00000013000)

Pin	Function	Wire Color
1	GND (0V)	BLACK
2	CH A\ (A)	BLUE/BLK
3	CH A (A)	BLUE
4	CH B (B)	GREEN
5	CH B\ (B)	GRN/BLK
6	CH Z (Z)	YELLOW
7	CH Z\ (Z)	YEL/BLK
8	+5V (+5V)	RED
9	-	-
10	CH U (RLG U)	BROWN
11	CH V (RLG V)	GRAY
12	CH W (RLG W)	WHITE