

# Accessory Assembly Instruction – 403XE

(For IGES and STEP files)

General Instructions	.....2
Limit/Home Switches	.....3
Sensor Pack	.....4
Cover	.....5
Motor Adapter	.....6
Motor	.....7

General Instructions:

- The files referred to in this document are to be used with the 403XE positioner. The standard 403XE positioner can be obtained by downloading the 403XE .igs (IGES) or .stp (STEP) from Daedal's website, [www.parkermotion.com](http://www.parkermotion.com).
- All files are in .zip format. When unzipping files, be sure to note their location and unzip all files to that location.
- Some of the accessory files are assemblies. These files must be imported as assemblies when using .stp (STEP) format.
- Follow the individual accessory instructions in the following pages.

## Limit/Home Switches

Accessory files to be used:

403XE-T##\_LIMIT\_HOME\_SWITCHES.igs      403XE-T##\_LIMIT\_HOME\_SWITCHES.stp

Substitute the travel code number, 01, 02, etc. for the ## characters.

Instructions:

1. Align the holes in the top of carriage with the limit/home switch tripper screws, shown with blue arrows.
2. Mate the surfaces of the carriage and the limit/home switch tripper, shown with red arrows. (Use the bottom surface of the tripper, surface not shown in view below.)

Note:

Standard limit/home switch location is shown below (limit/home switches on left hand side of table when looking at the motor end).

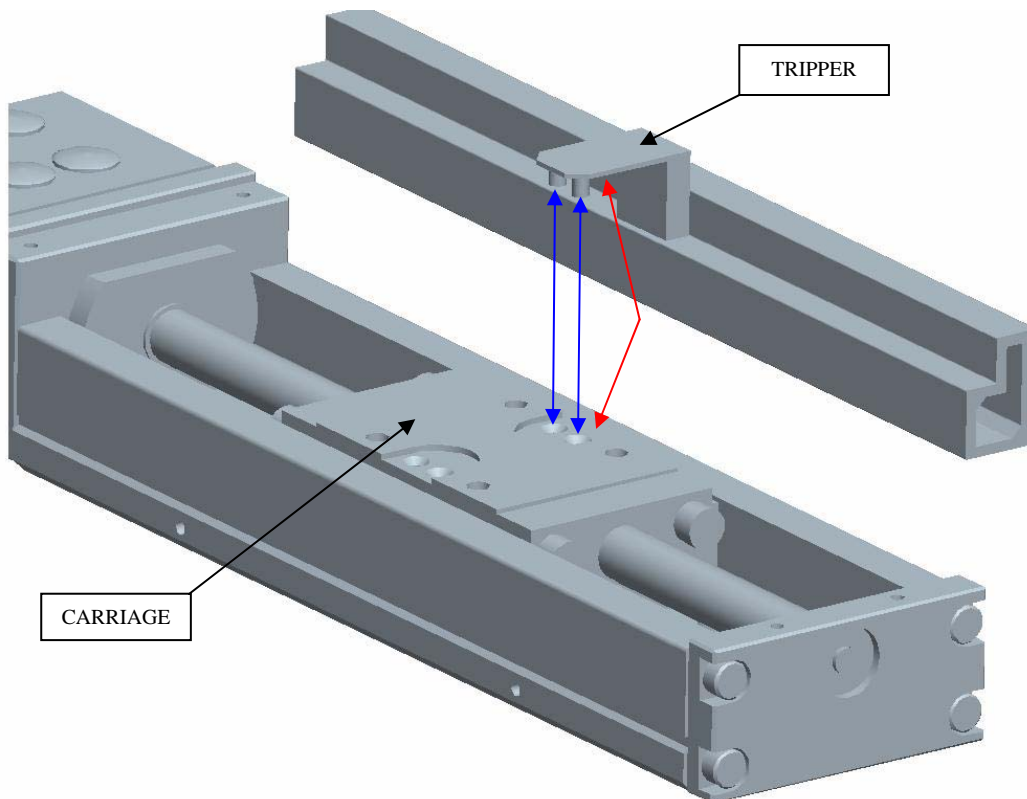

## Sensor Pack

Accessory files to be used:

403XE-T##\_SENSOR\_PACK.igs

403XE-T##\_SENSOR\_PACK.stp

Substitute the travel code number, 01, 02, etc. for the ## characters.

Instructions:

1. Align the holes in top of carriage with the limit/home switch tripper screws, shown with blue arrows.
2. Mate the surfaces of the carriage and the limit/home switch tripper, shown with red arrows. (Use the bottom surface of the tripper, surface not shown in view below.)

Note:

Standard sensor pack location is shown below (sensor pack on left hand side of table when looking at the motor end).

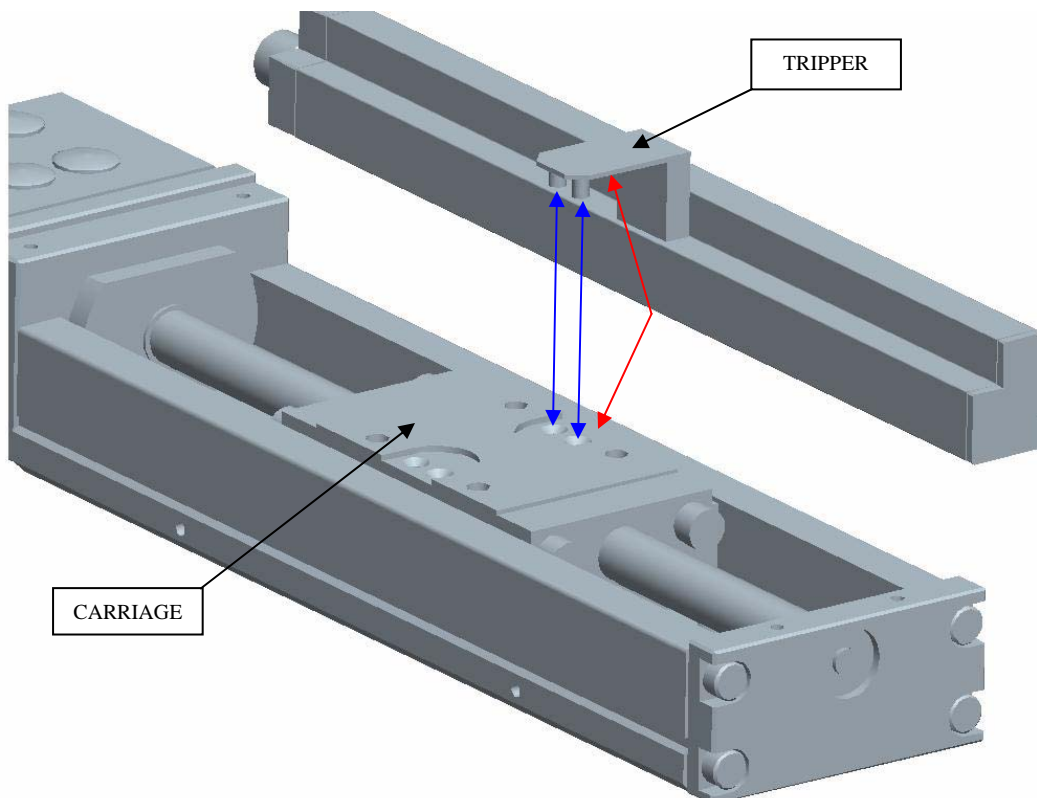

# Cover

Accessory files to be used:

403XE-T##\_COVER.igs

403XE-T##\_COVER.stp

Substitute the travel code number, 01, 02, etc. for the ## characters.

Instructions:

1. Align the holes in the end block with the cover screws, shown with blue arrows.
2. Mate the surfaces of the end block and the cover standoff, shown with red arrows. (Use the bottom surface of the standoff, surface not shown in view below.)

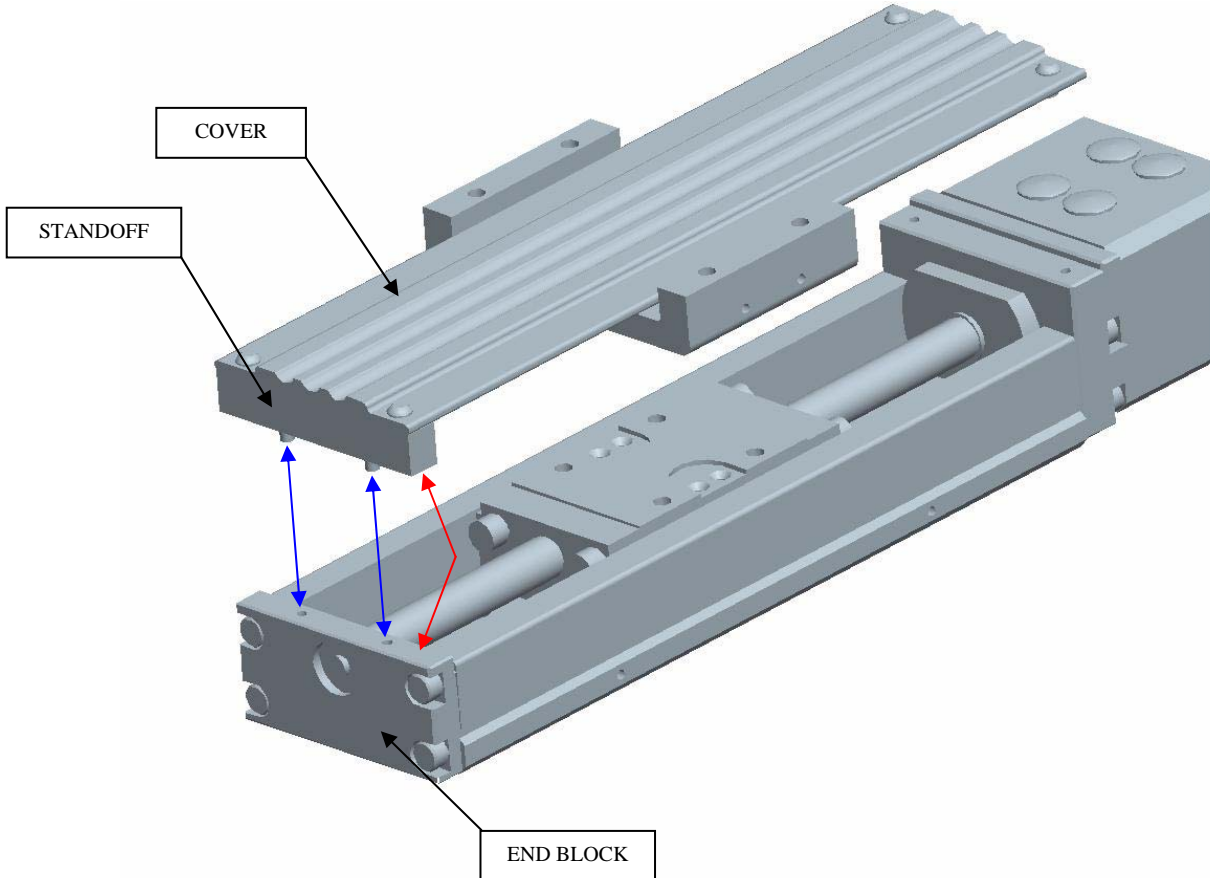

## Motor Adapter

Accessory files to be used:

403XE-M2\_MOTOR\_ADAPTER.igs  
403XE-M3\_MOTOR\_ADAPTER.igs  
403XE-M37\_MOTOR\_ADAPTER.igs  
403XE-M61\_MOTOR\_ADAPTER.igs

403XE-M2\_MOTOR\_ADAPTER.stp  
403XE-M3\_MOTOR\_ADAPTER.stp  
403XE-M37\_MOTOR\_ADAPTER.stp  
403XE-M61\_MOTOR\_ADAPTER.stp

Instructions:

1. Align the holes in the motor block with the motor adapter screws, shown with blue arrows.
2. Mate the surfaces of the motor block and the motor adapter, shown with red arrows. (Use the back surface of the motor adapter, surface not shown in view below.)

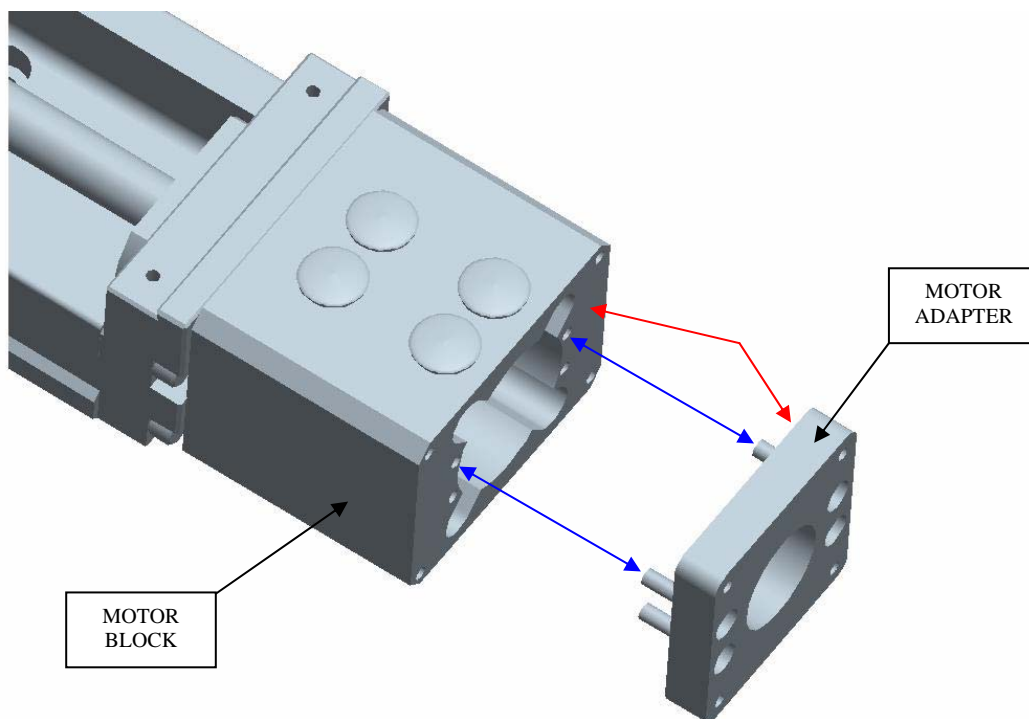

# Motor

Accessory files to be used:

403XE-M41\_MOTOR.igs  
403XE-M42\_MOTOR.igs  
403XE-M46\_MOTOR.igs

403XE-M41\_MOTOR.stp  
403XE-M42\_MOTOR.stp  
403XE-M46\_MOTOR.stp

Instructions:

1. Align the holes in the motor block with the motor adapter screws, shown with blue arrows.
2. Mate the surfaces of the motor block and the motor adapter, shown with red arrows. (Use the back surface of the motor adapter, surface not shown in view below.)

Note:

Standard motor orientation is shown below (motor cables exiting toward left hand side of table when looking at the motor end).

