



Automation

Divisione S.B.C.



HPD

HPD2, HPD5, HPD8,
HPD16

User's manual

rev. 7
January 1997
software rel. 18

HPD

HIGH PERFORMANCE DRIVE

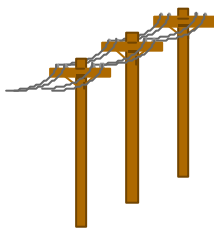
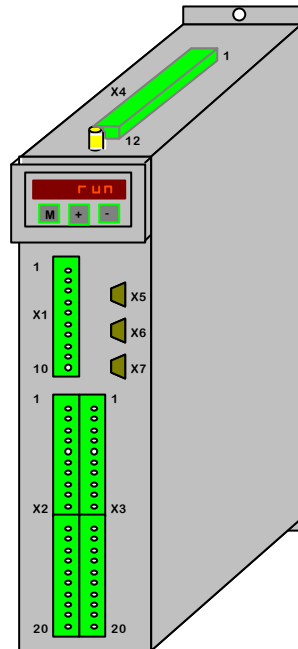

RS-485 or RS-422 SERIAL LINK

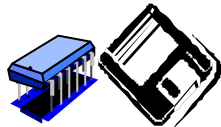

SOFTWARE & HARDWARE
EXPANSION

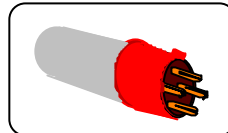

EXTENDED
VOLTAGE RANGE

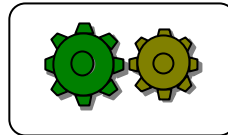

DIGITAL-LOCK
VARIABLE RATIO

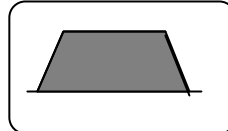

POSITIONER



STEP MOTOR
SIMULATION



EASY
MAINTENANCE

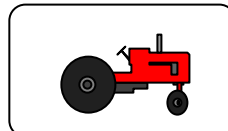

TORQUE CONTROL



ACCELERATION
CONTROL

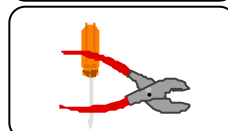

SPINDLE ORIENTATION
FOR TOOL CHANGING

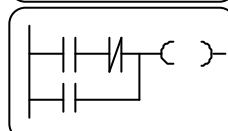

BUILT-IN P.L.C.

Parker Hannifin S.p.A.

Divisione S.B.C.

Via Gounod, 1 – 20092 Cinisello B.

(Milano) – Italy

Phone: +39-02-66012478

Fax: +39-02-66012808

E-mail: drivesbc@parker.com

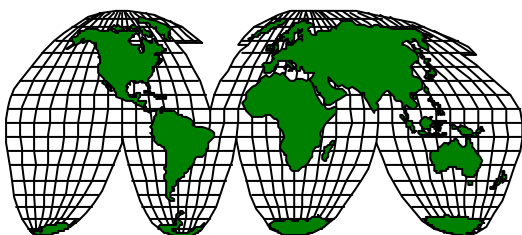

HPD :
everywhere
for any
application

WARNING

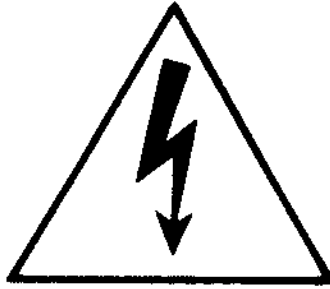

HIGH VOLTAGE !

Certain circuits in the **HPD** drive carry dangerously high voltages that could cause serious personal injury or death.

Do not attempt to service any parts of the drive when it is connected to the power supply.

If you need to access internal parts, before working on the drive allow at least 15 minutes after power-down to allow the DC bus capacitors to discharge. It is the User's responsibility to make sure that the installation is executed in accordance with established industrial health and safety standards.

In relation to the interpretation of standards, note that the drive is considered as a component and not as a machine.

Any tampering or unauthorised modification of the drive will invalidate the guarantee immediately. Guarantee cover is otherwise provided for 1 (one) year.

This instruction manual is applicable to the standard version of the drive.

Parker Hannifin S.p.A. - Divisione S.B.C. declines all liability for any whatsoever form of damage caused by inappropriate use of the drive.

Installation and maintenance of the drive and connected equipment must be performed exclusively by qualified and trained personnel with basic skills in electronics.

Commissioning of the drive must be performed exclusively by qualified and trained personnel with advanced skills in electronics and drive technology.

Training courses can be supplied by Parker Hannifin S.p.A. - Divisione S.B.C. on request.

The quoted performance of the HPD drive is guaranteed only when used with series MB synchronous motors manufactured by Parker Hannifin S.p.A. - Divisione S.B.C.

CONTENTS:

| | | |
|----------|--|-----------|
| 1 | <i>INTRODUCTION</i> | 5 |
| 1.1 | General information..... | 5 |
| 1.2 | Product description..... | 5 |
| 1.3 | Direct mains connection..... | 6 |
| 1.4 | Identification..... | 6 |
| 1.5 | Main hardware characteristics..... | 7 |
| 1.6 | Software features..... | 8 |
| 1.7 | Compliance with EMC standards..... | 8 |
| 1.8 | Safety..... | 8 |
| 2 | <i>INSTALLATION</i> | 9 |
| 2.1 | Safety instructions..... | 9 |
| 2.2 | Interference suppression hints..... | 10 |
| 2.3 | Mains filter installation instructions..... | 10 |
| 2.4 | Control cubicle layout example..... | 12 |
| 2.5 | HPD drive mains filters..... | 13 |
| 2.6 | Terminal assignments..... | 20 |
| 2.7 | Power connections..... | 22 |
| 2.8 | Power connection layout..... | 23 |
| 2.9 | Signal cable connections..... | 23 |
| 2.10 | Signal cable connection layout..... | 24 |
| 2.11 | Frequency input connection..... | 24 |
| 2.11.1 | Encoder emulation..... | 25 |
| 2.12 | Serial line connection..... | 26 |
| 2.13 | Braking resistor..... | 26 |
| 2.14 | Backup..... | 27 |
| 3 | <i>PARAMETERS AND PROGRAMMING</i> | 28 |
| 3.1 | Using the keypad..... | 29 |
| 3.2 | Commissioning the HPD drive..... | 30 |
| 3.3 | Basic parameters..... | 33 |
| 3.4 | Basic commands..... | 38 |
| 3.5 | Calibrating speed loop..... | 39 |
| 3.6 | Operating modes..... | 45 |
| 3.6.1 | Torque control..... | 45 |
| 3.6.2 | Acceleration control..... | 45 |
| 3.6.3 | Maintenance and commissioning..... | 46 |
| 3.6.4 | Positioner..... | 47 |
| 3.6.5 | Digital locking..... | 49 |
| 3.6.6 | Stepper motor emulation..... | 51 |
| 3.6.7 | Spindle orientation..... | 52 |
| 3.7 | Block diagrams..... | 52 |
| 3.8 | Digital input and output programming..... | 59 |
| 3.8.1 | Pico-PLC..... | 59 |

| | | |
|----------|---|-----------|
| 3.8.2 | Examples and applications..... | 63 |
| 3.9 | Programming with Pcbrush..... | 79 |
| 4 | <i>SERIAL INTERFACE</i> | 80 |
| 4.1 | Communication protocol..... | 80 |
| 4.2 | Serial addresses and parameter lengths..... | 85 |

APPENDIXES

| | | |
|---|--|----|
| A | HPD drive mechanical dimensions..... | 87 |
| B | MB series motor connectors..... | 88 |
| C | Hardware characteristics..... | 89 |
| D | DC bus voltage thresholds..... | 90 |
| E | Conventions..... | 90 |
| F | Software timers..... | 91 |
| G | Pico-PLC default program..... | 92 |
| H | Flash information..... | 93 |
| I | S.B.C. filter physical dimensions..... | 94 |
| L | Remote communications interface..... | 96 |
| M | Application description form..... | 97 |

1 - INTRODUCTION

1.1 General information

This manual describes operations required for the installation and commissioning of the HPD (High Performance drive) drive for brushless motors. Read all chapters of the manual carefully before using the drive.

1.2 Product description

The HPD drive is a digital frequency converter for driving AC brushless motors. The adoption of a Parametric Operator Interface makes drive configuration procedures faster and easier to repeat. The large number of configuration possibilities makes the drive suitable for numerous applications.

A high power 16 bit micro-controller allows speed control with the characteristics required of a servo controller, plus a range of auxiliary functions that can help reduce the presence of control electronics in the application and thus permit considerable economic savings.

In addition to the positioner functions with trapezoidal profile, digital lock, spindle orientation, stepper motor emulation, torque control and acceleration control, the HPD drive also has an internal pico-PLC. The pico-PLC adopts the most diffused industrial programming standards and offers considerable freedom for use of inputs and outputs. It also enables users to develop a range of additional functions that are not among the basic features of the drive.

The HPD drive is complete with an RS-422/RS-485 serial interface which can be used for configuration, monitoring, or simultaneous transmission of commands to a multiple system comprising up to 32 HPD drives.

In addition to the above functionality, the HPD drive is designed as an open system with the facility to accommodate hardware and software expansion cards. For further information on currently available expansion cards contact Parker Hannifin S.p.A. - Divisione S.B.C. directly or your local Dealer.

1.3 Direct mains connection

The HPD series of drives is specifically designed for direct connection to a three-phase mains power supply from 90 to 460V~ 50/60 Hz, without interposing transformers. It is the responsibility of the User to connect the system via protection fuses. The use of single phase power supplies is permitted although motor power output must be derated in this case. Maximum motor power is calculated by the following formula:

$$P_{max} = 27 \times 10^{-3} V_{mains}^2 \text{ [watt]}.$$

All protections required for safety, such as overvoltage detection, short circuit fault protection and inverter and motor overtemperature detection are integral with the drive.

Mains filters and motor filters must be calculated during the design of the electrical cubicle so that EMC standards are met in order to qualify for CE marking.

Chapter 2 provides a detailed view of problems related to EMC.

N.B. leave at least 60 sec. after switching the drive off before switching it on again.

1.4 Identification

HPD drives are available in 4 models: HPD 2, HPD 5, HPD 8 and HPD 16. The number that follows HPD is the value of drive rated current in amperes.

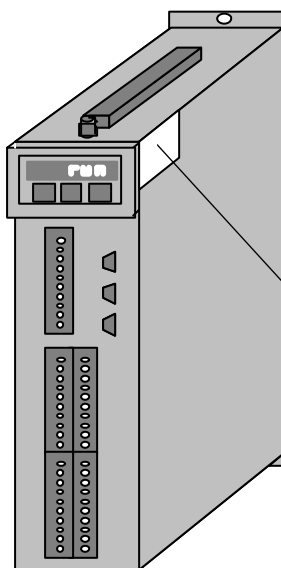

HPD drives carry an identification plate on the right hand side showing all essential information for correct identification of the unit. **Make a note of the information on this plate before consulting S.B.C. on technical matters.**

The identification plate is shown below.

model
identification plate

1.5 Main hardware specifications

| <i>Parameter</i> | <i>U.M.</i> | <i>Value</i> | | | |
|-----------------------------------|---------------------|-----------------|------|------|-------|
| Power supply | V~ | 90..460 | | | |
| Models | | HPD2 | HPD5 | HPD8 | HPD16 |
| Rated output current | A | 2 | 5 | 8 | 16 |
| Peak output current (4 s) | A | 4 | 10 | 16 | 32 |
| Output power (400 V~) | kW | 1 | 2.5 | 4.1 | 8.3 |
| Control electronics dissipation | W | 18 | | | |
| Dissipation from power components | W | 25 | 60 | 89 | 158 |
| Ambient temperature | °C | 45 | | | |
| Braking resistor | internal / external | | | | |
| Rated power of braking resistor | W | 120 | | | |
| Feedback | resolver (speed 1) | | | | |
| Power stage switching frequency | KHz | 8 | | | |
| Maximum output frequency | Hz | 450 | | | |
| Protection category | IP 20 | | | | |
| Digital inputs 24V | Nº | 8 | | | |
| Digital outputs 24V -100mA PNP | Nº | 6 | | | |
| Voltage-free digital outputs | Nº | 1 | | | |
| Encoder emulation RS-422 | steps/rev | 128..16384 | | | |
| Frequency / sign or encoder input | KHz | 800 / 200 | | | |
| Analogue reference | V | ±10 diff 15 bit | | | |
| Auxiliary analogue input | V | ±10 diff 10 bit | | | |
| Analogue monitor output | V | ±10 - 8 bit | | | |
| Tacho generator emulation output | V | ±10 V | | | |
| Serial line | RS-422 / RS-485 | | | | |
| Backup for encoder emulation | V | 24 d.c. | | | |
| Backup for encoder emulation | A | max. 2 | | | |

1.6 Software features

The following capabilities are implemented in the basic software supplied with the HPD drive:

- Speed control
- Advanced torque limit manager
- Speed windows management
- Positioning with trapezoidal speed profile
- Digital locking functions with variable transmission ratio and phase shifting
- Spindle orientation
- Stepper motor emulation
- Torque control with overlaid speed control
- Acceleration ramp control with overlaid speed control
- Simplified maintenance and start-up mode
- Internal PLC for advanced input/output programming functions

1.7 Compliance with EMC standards

Immunity:

| | | |
|----------------------------|---------|---|
| EN50082-1* / EN50082-2 | | Basic immunity specifications |
| IEC1000-4-2 (ex IEC 801-2) | level 3 | Electrostatic discharge immunity |
| IEC1000-4-3 (ex IEC 801-3) | level 3 | Electromagnetic field immunity |
| IEC1000-4-4 (ex IEC 801-4) | level 4 | Fast transient burst conducted immunity |

Compatibility:

| | |
|---------------------------|---|
| EN50081-1* / EN50081-2 | Basic radio interference specifications |
| EN55011 group 1, class A | Measurement limits for radio interference |
| EN55011 group 1, class B* | Measurement limits for radio interference |

1.8 Safety

Safety standard EN60065

Low voltage Directive 73/23/CEE amended by 93/68/CEE
Applied standard EN60204-1

* Conformity for use in domestic or industrial surroundings depends on the nature of the installation.

2 - INSTALLATION

- The HPD drive must be installed in a vertical position (power terminal block X4 at the top).
- Leave at least 190 mm clearance above and below the drive.

2.1 Safety instructions

- Make sure the drive is correctly sized for the motor you intend to connect. Compare rated voltage and current.
- Wire up electrical panel/drive/motor in accordance with the instructions in this section of the manual, taking into consideration EMC requirements and established safety legislation.
- The User is responsible for installing fuses on the drive A.C. power supply.
- Power conductors and control circuits must be kept apart (at least 20 cm) and, when they must cross, intersections must be at a right angle. Motor lines and mains power lines must never be parallel.
- All power conductors must be sufficiently sized (refer to table in heading 2.7; in all cases compliance with IEC227-2 must be guaranteed).
- Conductors connected to the system by means of the terminal strip must not be soldered (EN60065, art.15.3.5).
- Make sure drive and motor and properly earthed.
- Make sure that the maximum voltage on terminals L1, L2, L3 does not exceed rated voltage by more than 10% in the worst possible case (see EN60204-1, section 4.3.1). Excessively high mains feeding voltage can damage the drive.
- Do not detach electrical connections when the drive is connected to the power supply.
- Follow all installation instructions in this manual step by step. If you are in doubt, contact S.B.C. customer service.
- Dangerous voltages may remain for 60 seconds after mains disconnection and system power-down; do not touch power cables during this interval.
- Do not open the drive casing. This action is potentially dangerous and will automatically invalidate the guarantee.

Installation and wiring must be carried out with the entire electrical panel disconnected from the power supply. Make sure that the drive enable command is disconnected from the emergency circuit. Qualified technical personnel must preside when the power panel is powered up for the first time.

2.2 Interference suppression hints

Because of the high speed voltage wavefronts in PWM, high levels of stray current may sometimes flow through capacitive couplings and earth systems. Stray currents of this type can affect other functional units. It is therefore prudent to calculate the presence of an amount of spurious energy that depends on the size of the system (drives, motor lines, motor). Spurious energy generates EM radiation that can interfere with the operation of nearby systems. Existing standards do not set down limits for this type of radiation.

Preventive measures

Basic methods for preventing interference are: decoupling of drive from its surroundings, high quality and properly sized conductors to neutralise voltages (earthing), and adequate shielding. Shields, filters and drives must have a large contact area to achieve the maximum possible decoupling and hence optimal noise suppression. Attention must be paid, however, to the entire installation, as this is one of the most important precautions in assuring efficient noise suppression.

High frequency interference takes the form of radiation, especially from the motor lines. This effect can be reduced with the use of shielding.

Another essential counter-measure for noise suppression is the use of filters.

The use of filters is aimed at reducing conducted interference on wiring and the return of conducted interference to source (drive) through routes offering the lowest impedance. This method provides effective protection for other systems connected to the same electrical line, also protecting the drive from interference originating from other systems. When installing filters consider the mains input and motor feeding output; the motor feeding output can be protected with output filters that minimise interference levels (generally toroidal ferrite core coils bearing several windings of all three motor wires).

2.3 Mains filter installation instructions

To guarantee electromagnetic compatibility in compliance with the relevant standards the maximum priority must be awarded to EMC requirements when designing the control cubicle. To obtain the best results from filters follow the instructions in this section carefully, because

even a complex and expensive filter is ineffective unless it is installed taking EMC aspects into consideration.

Avoid:

- routing noise emitting cables parallel to “clean” cables
- parallel cables, especially in the vicinity of the filter (ensure physical separation)
- cable loops (keep cables as short as possible and close to the common potential).

Additional measures

- With the exception of mains cables to the filter, all power and control wiring must be shielded and, wherever possible, kept segregated (minimum distance 20 cm). If control and power cables must cross, the intersection must be at a right angle.

- Shielded cables must be installed on a copper bar by means of a high conductivity wire clamp. The area of contact must be as large as possible and the shield must be unbroken. In general the shield should be connected at each extremity. In certain circumstances, however, control cable shields may be connected only at one end to eliminate mains hum that could interfere with the control signal. Decide case by case as numerous factors must be considered. Adopt the following general approach: if the shield is solely for shielding, connect at both ends. If current flowing in the shield interferes with the shielded signals, connect at one end only.

- The incoming cable must be connected to an earth terminal by means of a screw to ensure proper contact between shield and earth.

- RF interference suppression filters must be installed as close as possible to the drive and must have a large area of contact with the power panel or the baseplate. Remove all paint. The filter earth terminal must be connected to the earth bar along the shortest possible route.

- As far as possible keep the power side (drive) and control side (PLC or NC) physically separated by separating the metal mounting plates. Do not route any cables through the mounting plates.

Protective measures for drives with > 3.5mA dispersion current per phase

Interference currents dispersed through the earth system may be considerable in certain conditions. Therefore, make sure all suppression filters are properly earthed before they are connected. Cable sizes must be in line with the requirements of safety standards.

If a suppression filter is permanently connected and current dispersion during normal operation is greater than 3.5mA (which would be expected with most drives) adopt one of the following measures additionally:

a) Increase shield size to at least 10 mm².

b) Install a detection system to monitor the shield and automatically disconnect the drive in the presence of faults.

c) Install a second conductor in parallel (electrically) with the shield using separate terminals.

The installer must ensure that filter terminals are protected.

2.4 Control cubicle layout example

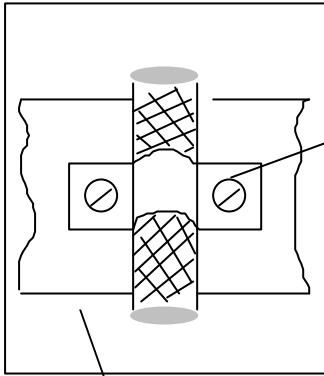

All conductors down-line of the mains filter must be shielded and mounted to a copper bar with large contact area. Also the copper bar must present an ample area of contact with the cubicle mounting plate.

Large surface area partition shield with generous contact area around perimeter. Remove paint from contact points in the cubicle.

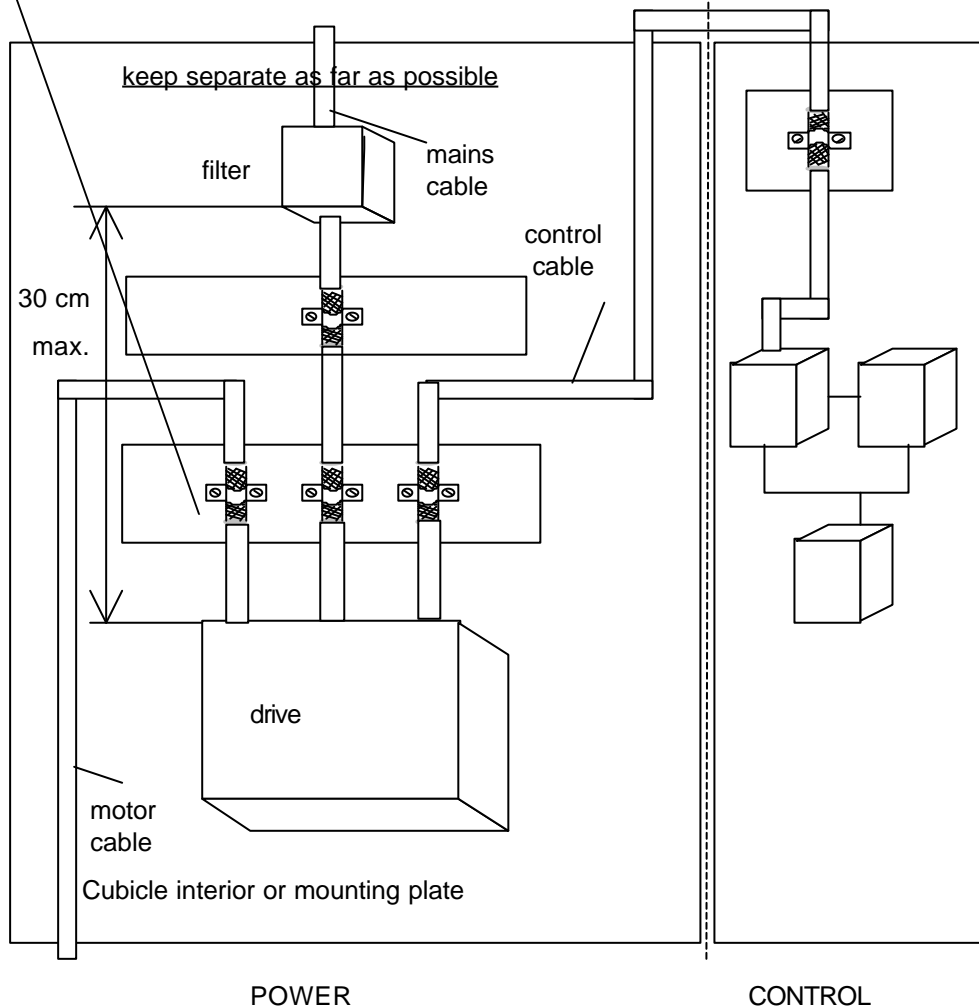

2.5 HPD drive mains filters

S.B.C. has developed a special series of filters for HPD drives. When the filters are installed in accordance with our instructions, compliance with EN55011-class A is guaranteed; for class B rating add a transformer to the power supply (shielded primary and secondary). Users must allow space in the control cubicle to accommodate filters implemented at the time of the project. S.B.C. filters provide both mains and motor output filter functions.

Filters of different manufacture can also be utilised. In this case **S.B.C. offers its technical support by testing the filter you intend to use and generating a test data report.**

CERTIFIED FILTER CONFIGURATIONS IN COMPLIANCE WITH EN55011 (group 1 classes A and B)

High attenuation S.B.C. three-phase filters are specifically designed for S.B.C. brushless motor drives in compliance with the standard IEC950 for stray current up to 3.5 mA (380 - 50 Hz) for semi-static equipment.

TECHNICAL FEATURES

| | |
|---------------|-----------------|
| Enclosure | metal |
| Temperature | -25 ... +85 °C |
| Rated voltage | 460 V~ 50/60 Hz |

S.B.C. FILTERS

| | type | current | enclosure |
|----------|-------|---------|-----------|
| SBC3R10 | mains | 10 | F6 |
| SBC3R20 | mains | 20 | F10 |
| SBC3R35 | mains | 35 | F7 |
| SBC3RD35 | mains | 35 | F5 |
| SBC3M10 | motor | 10 | F6 |
| SBC3M20 | motor | 20 | F6 |

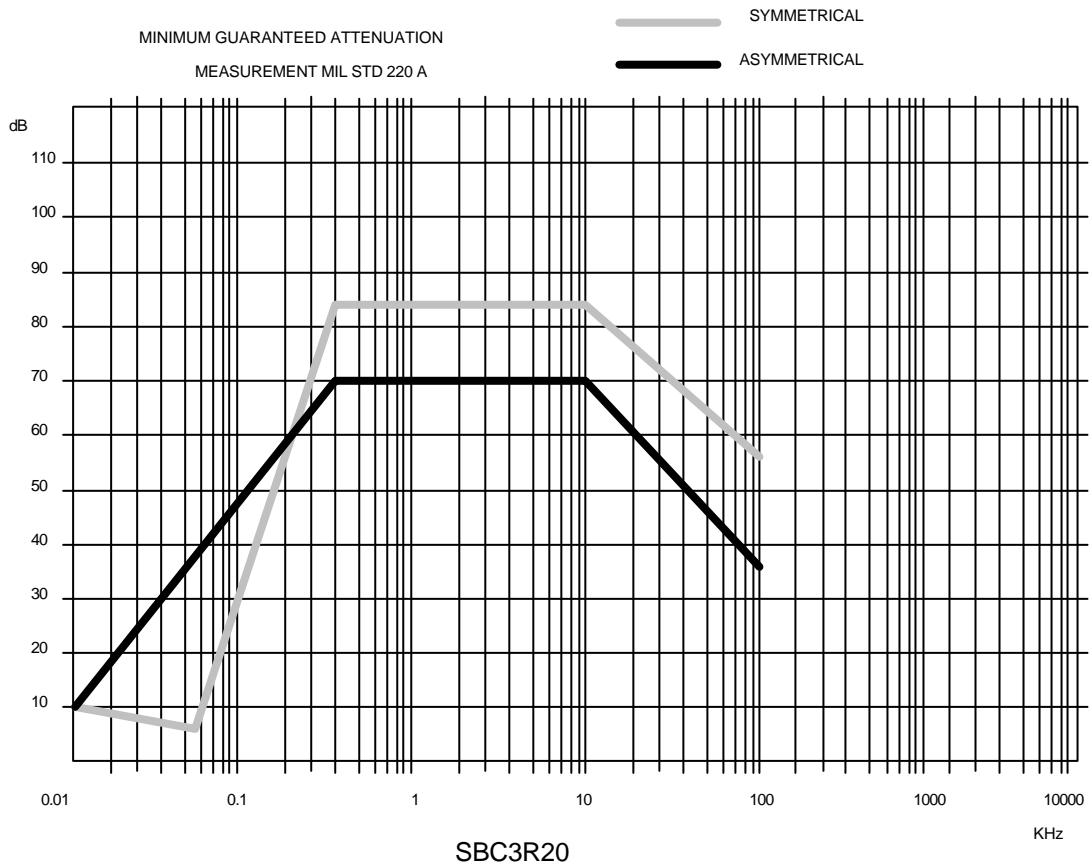
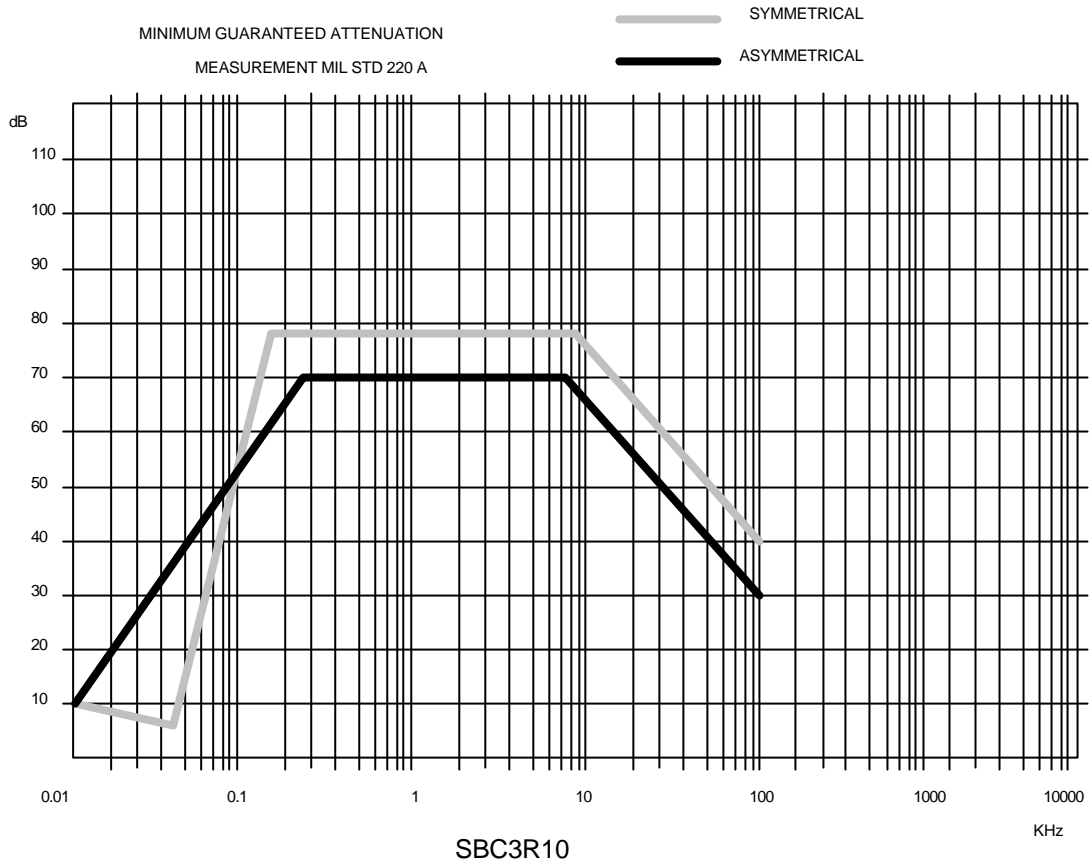

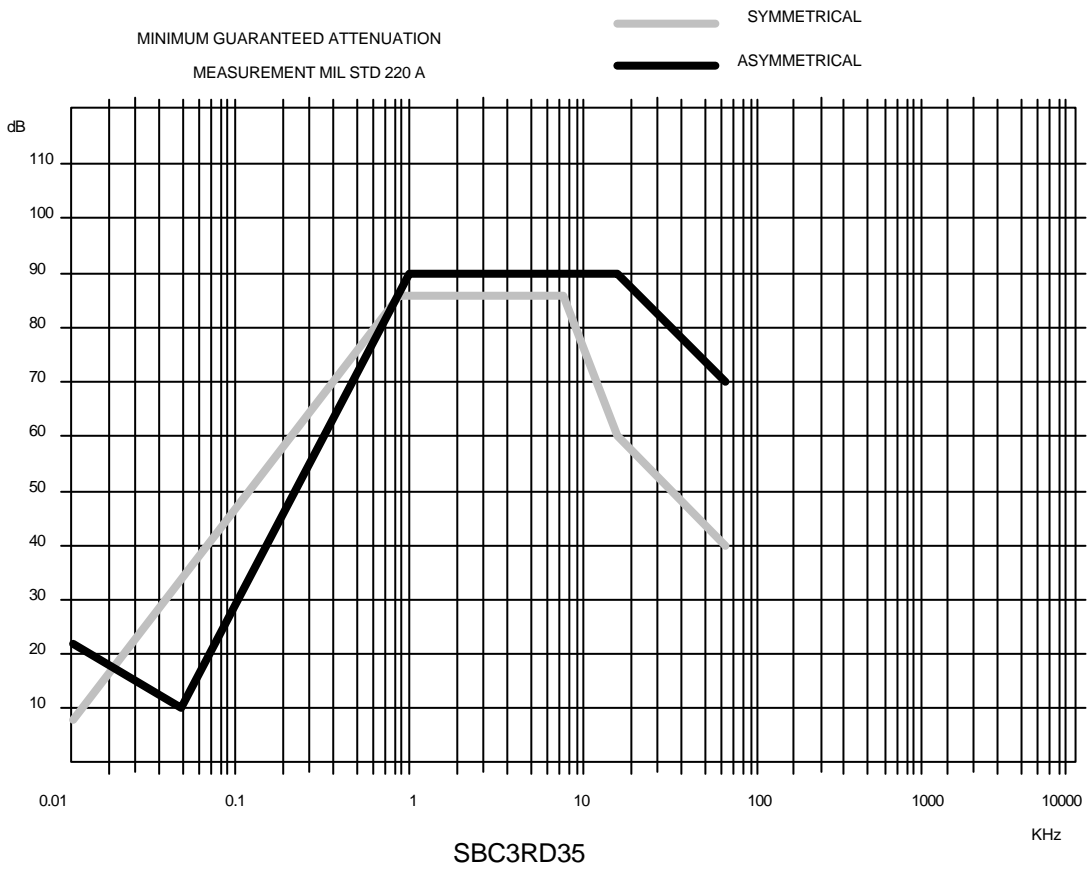
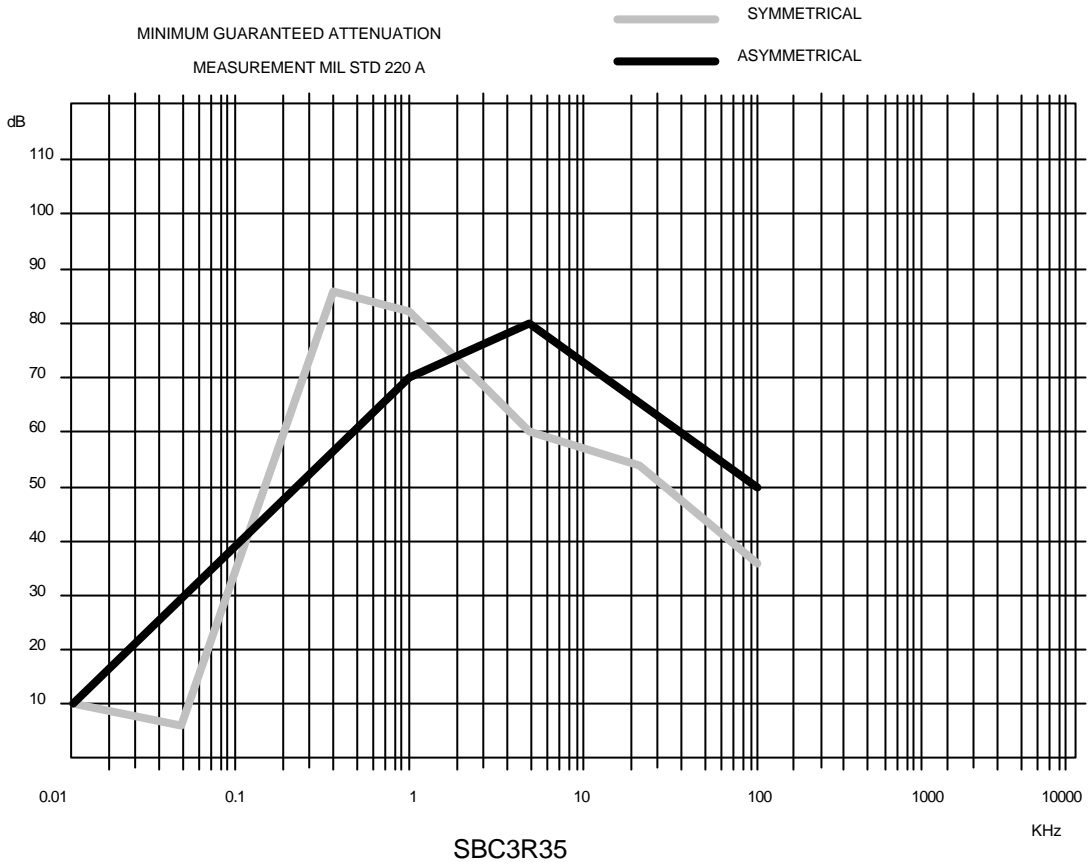

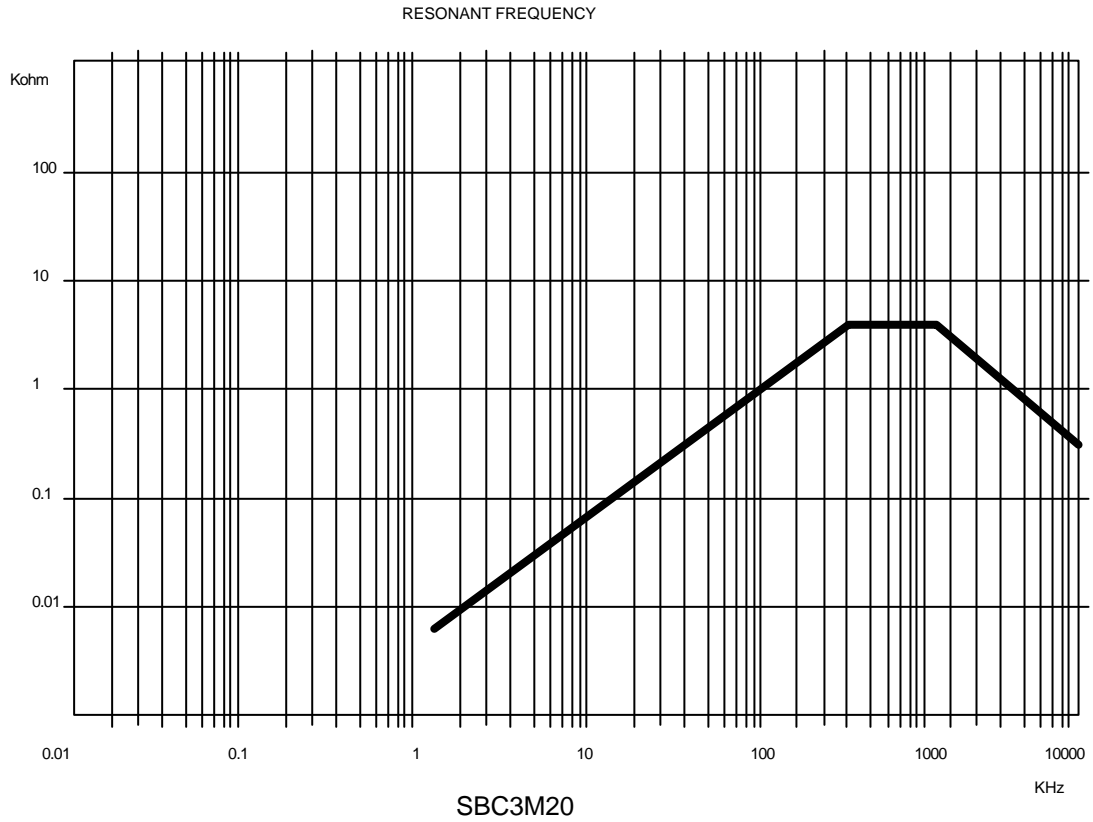
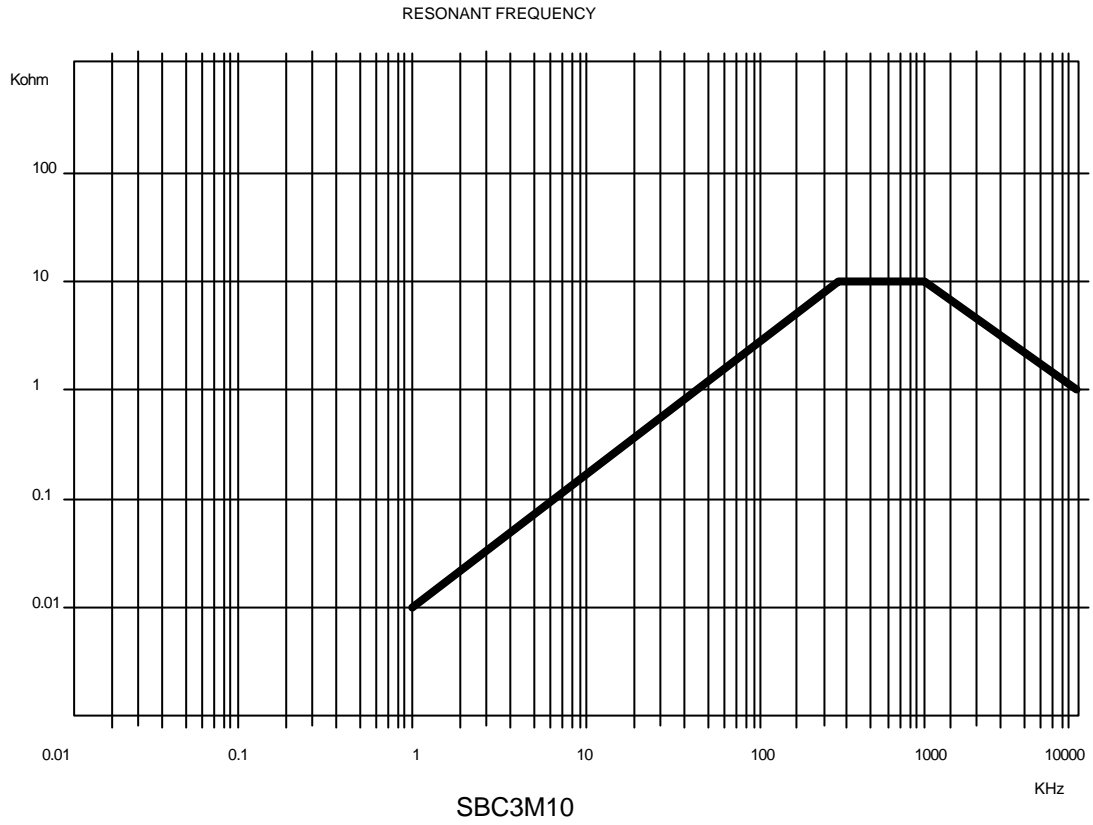

Configuration 1 Class A

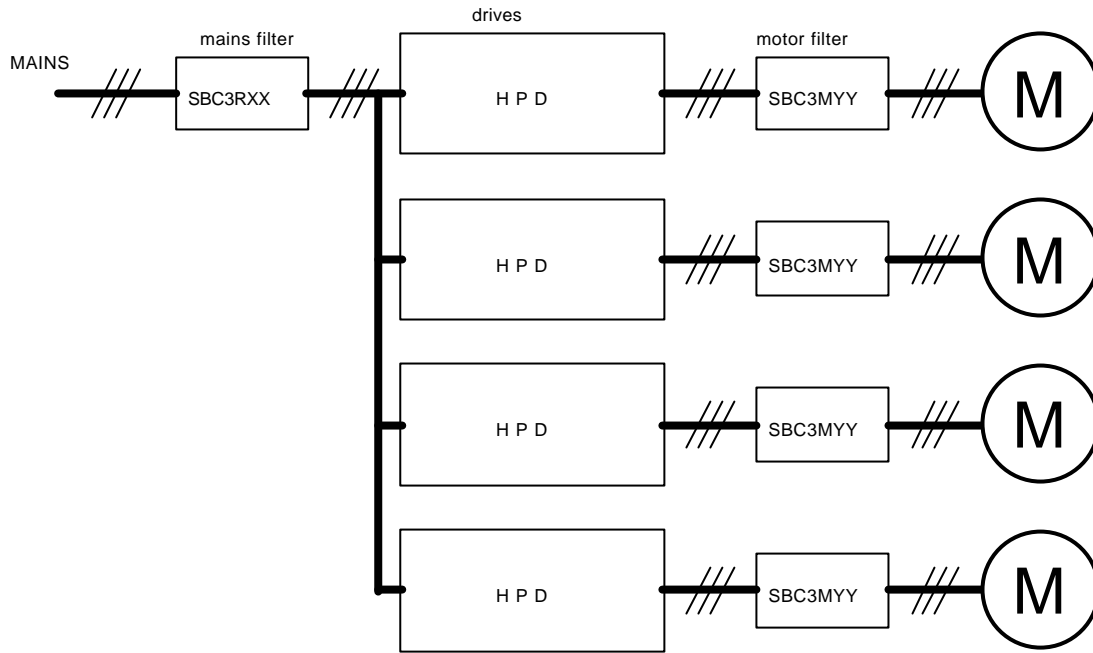

Where HPD rating is between 2 and 16 A

XX can be 10, 20 or 35 and stands for the mains filter rated current; the sum of drive rated currents must not exceed the mains filter rated current.

YY can be 10 or 20 and represents the motor filter rated current the drive rated current must not exceed that of the filter

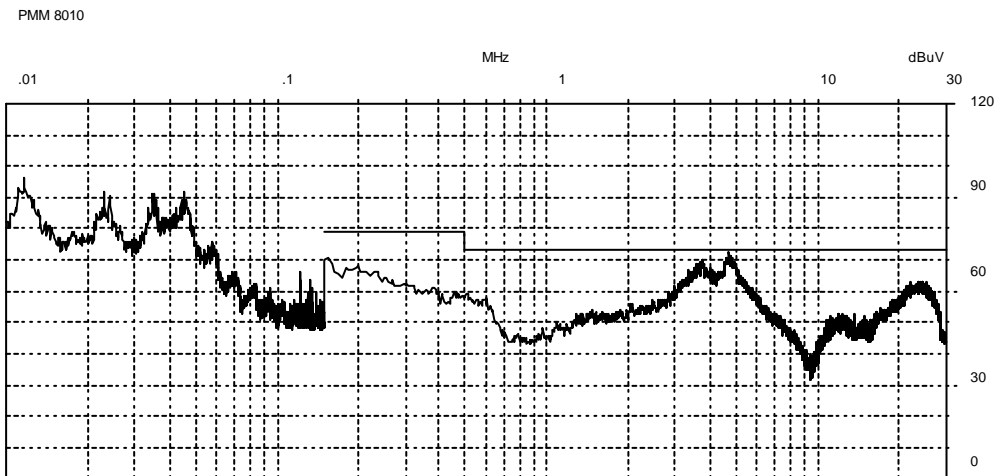

Limit: C22_A_QP

Title: DEFINIT4

Date: 06-25-1995

Configuration 2 Class A

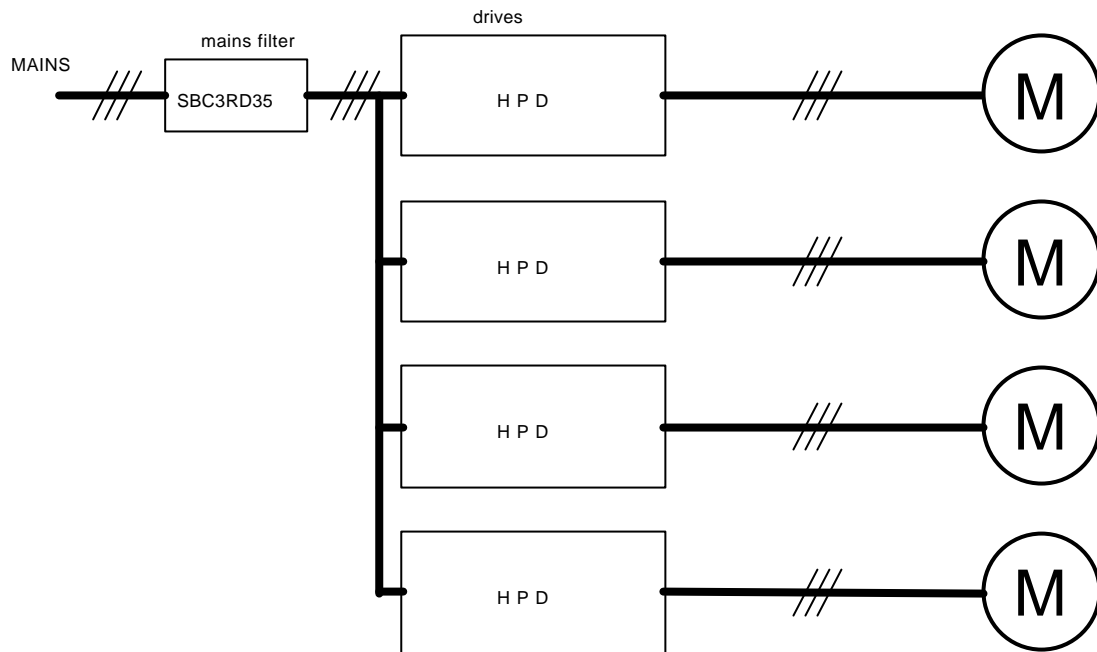

Where HPD rating is between 2 and 16 A

the sum of drive rated currents must not exceed 35 A

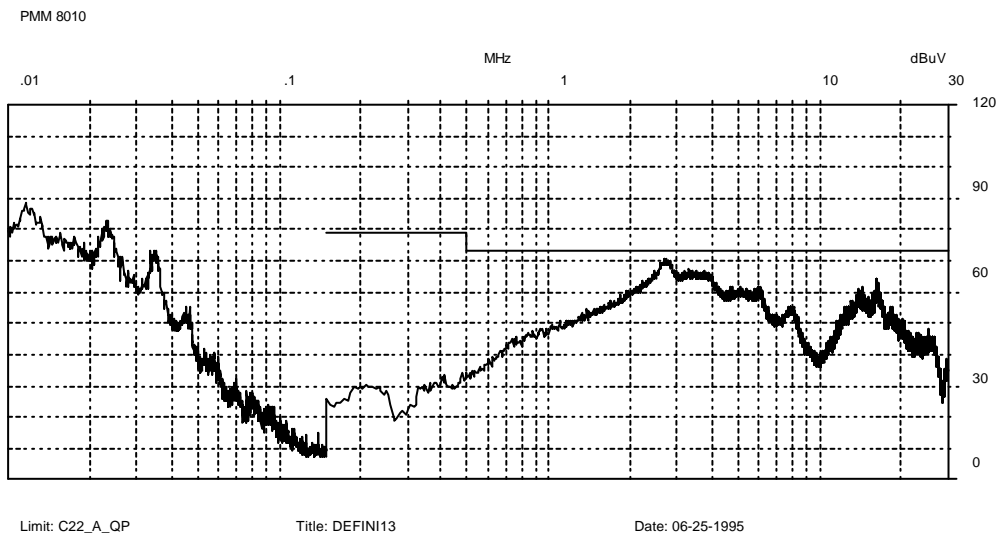

Configuration 3 Class B

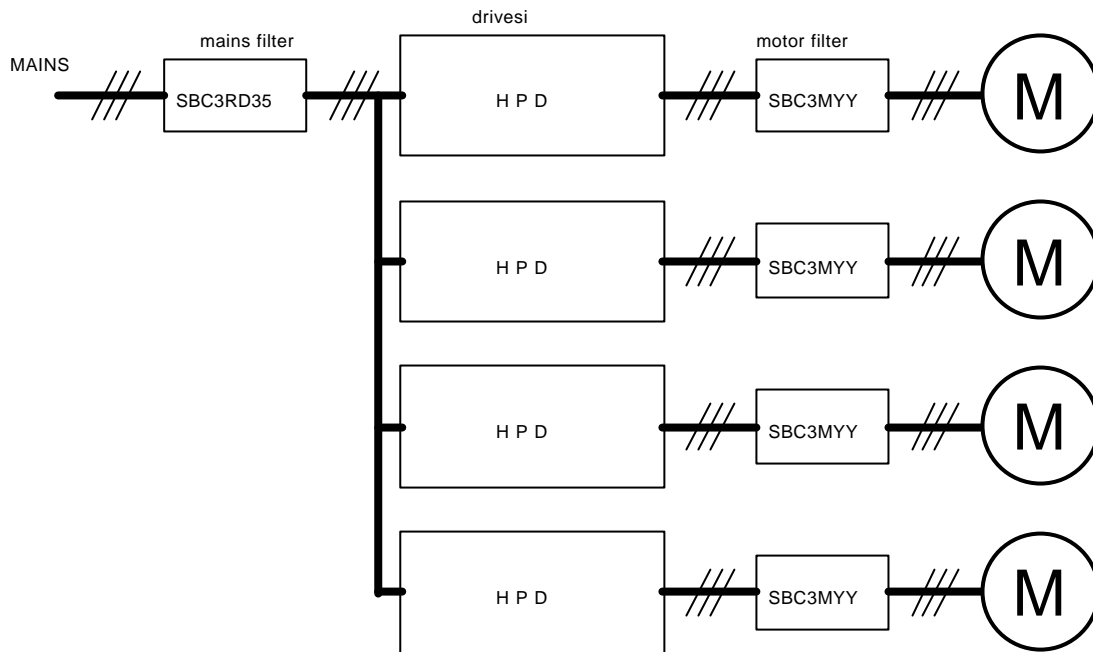

Where HPD rating is between 2 and 16 A

The sum of drive rated current values must not exceed 35 A

YY can be 10 or 20 and represents the motor filter rated current; drive rated current must not exceed that of the filter

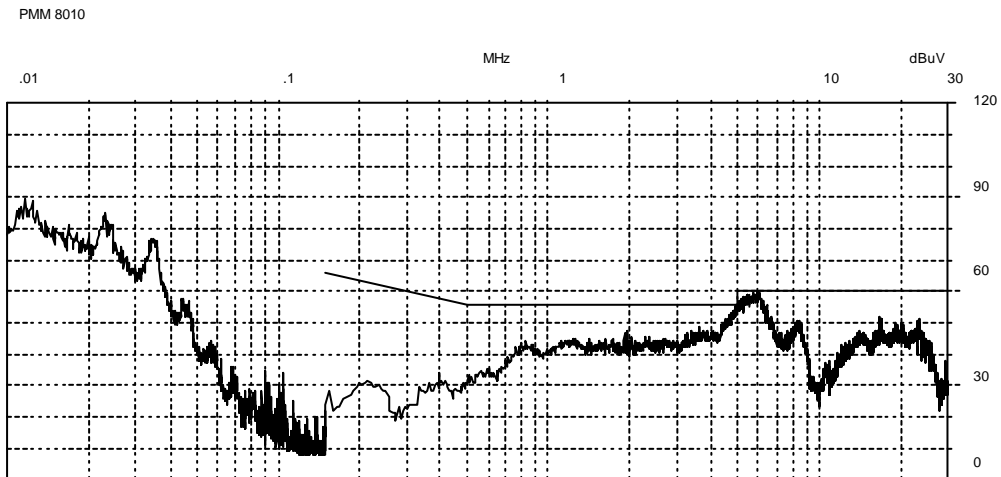

Limit: C22_B_OP

Title: DEFINI12

Date: 06-25-1995

2.6 Terminal assignments

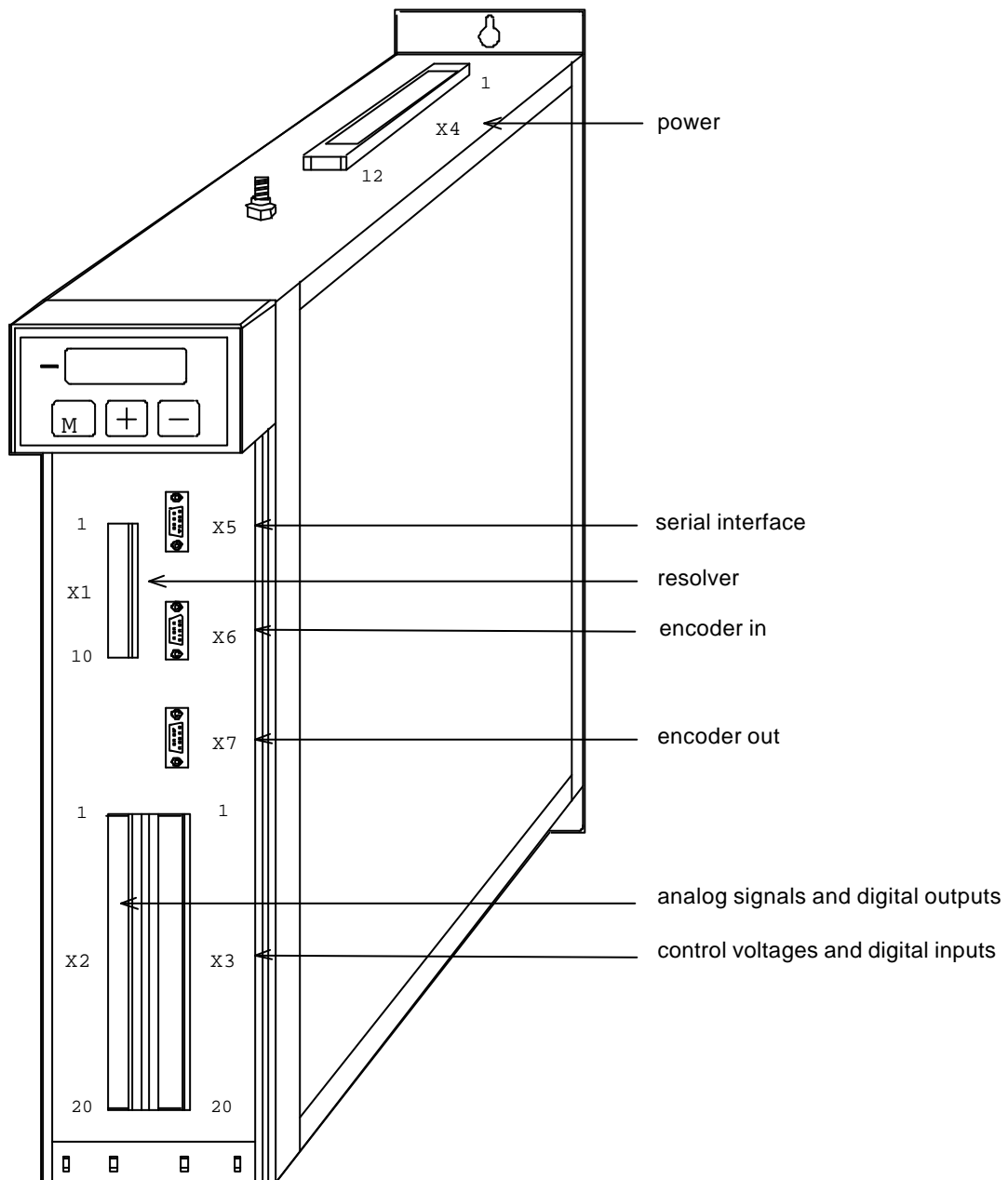

| Terminal board X1 | |
|-------------------|----------------------|
| 1 | motor PTC + (24 V) |
| 2 | motor PTC - |
| 3 | resolver Excit. high |
| 4 | resolver Excit. low |
| 5 | resolver Sin high |
| 6 | resolver Sin low |
| 7 | resolver Cos high |
| 8 | resolver Cos low |
| 9 | 0 V |
| 10 | 0 V |

| Terminal board X4 | |
|-------------------|-----------------------|
| 1 | LIVE 1 |
| 2 | LIVE 2 |
| 3 | LIVE 3 |
| 4 | U PHASE |
| 5 | V PHASE |
| 6 | W PHASE |
| 7 | A-BUS |
| 8 | B-BUS |
| 9 | BRAKE COMMAND |
| 10 | INTER. BRAKE RESISTOR |
| 11 | + DC BUS |
| 12 | - DC BUS |

| Terminal board X2 | |
|-------------------|----------------------|
| 1 | reference high |
| 2 | reference low |
| 3 | 0 V |
| 4 | Aux reference high |
| 5 | Aux reference low |
| 6 | 0 V |
| 7 | Aux. analogue output |
| 8 | 0 V |
| 9 | tacho output |
| 10 | 0 V |
| 11 | digital out 0 |
| 12 | digital out 1 |
| 13 | digital out 2 |
| 14 | digital out 3 |
| 15 | digital out 4 |
| 16 | digital out 5 |
| 17 | digital out 6 A |
| 18 | digital out 6 B |
| 19 | + 24 V - OUT 200 mA |
| 20 | 0 V |

| Terminal board X3 | |
|-------------------|---------------------|
| 1 | + 10 V - 10 mA max |
| 2 | 0 V |
| 3 | - 10 V - 10 mA max |
| 4 | 0 V |
| 5 | + 24 V - IN |
| 6 | 0 V |
| 7 | 0 V |
| 8 | + V backup |
| 9 | - V backup |
| 10 | 0 V |
| 11 | drive enable |
| 12 | digital input 1 |
| 13 | digital input 2 |
| 14 | digital input 3 |
| 15 | digital input 4 |
| 16 | digital input 5 |
| 17 | digital input 6 |
| 18 | digital input 7 |
| 19 | + 24 V - OUT 200 mA |
| 20 | 0 V |

| D type X5 | |
|-----------|-----|
| 1 | TX |
| 2 | RX |
| 3 | /TX |
| 4 | /RX |
| 5 | |
| 6 | +BR |
| 7 | -BR |
| 8 | 0 V |
| 9 | 0 V |

| D type X6 | |
|-----------|------|
| 1 | A |
| 2 | /A |
| 3 | B |
| 4 | /B |
| 5 | -BRA |
| 6 | +BRB |
| 7 | 0 V |
| 8 | -BRB |
| 9 | +BRA |

| D type X7 | |
|-----------|------|
| 1 | PHA |
| 2 | /PHA |
| 3 | PHB |
| 4 | /PHB |
| 5 | PHC |
| 6 | /PHC |
| 7 | 0 V |
| 8 | |
| 9 | |

2.7 Power connections

For the motor cable consider

Choice between cable for fixed or floating installation.

Cable must be shielded and suitably sized in terms of insulation and wire sections.

Reticulated polypropylene is the preferred insulation material.

Length (max 100 m); note that conductor-conductor capacitance must not exceed 8 nF.

If cable length exceeds 50 m install a triple 1 mH inductance between drive and motor with rated current identical to HPD rated current.

Minimum conductor size is 1.5mm² for HPD2 and HPD5 , 2.5mm² for HPD8 and 4mm² for HPD16.

For the mains power cable

Power cables must not be shielded.

Minimum conductor size is 1.5mm² for HPD2 and HPD5, 2.5mm² for HPD8 and 4mm² for HPD16.

Input fuses must be rated as follows:

| <i>MODEL</i> | <i>Slow blow fuses (A)</i> |
|--------------|--------------------------------|
| HPD2 | 6 |
| HPD5 | 10 |
| HPD8 | 16 |
| HPD16 | 20 |

Resolver cable

The cable must comprise 4 twisted pairs with individual shields and one common shield.

Capacitance for the length of cable must not exceed 10 nF; wire size must be no less than 0.35mm².

Maximum length is 100 m.

EMI filter connection

The connection between filter and drive must never exceed 30 cm. If the distance is less than 15 cm unshielded cables are possible, otherwise a shielded cable must be used.

Earth connections

To reduce the length of individual conductors that must be connected to earth we recommend using an earth busbar located as near as possible to the drive.

The busbar must be made of copper to ensure low inductance. It must also be mounted on insulated fixings. The adjacent table shows minimum dimensions according to length.

| <i>Length (m)</i> | <i>width (mm)</i> | <i>thickness (mm)</i> |
|-------------------|-------------------|---------------------------|
| 0.5 | 20 | 6 |
| 1 | 40 | 6 |
| 1.5 | 50 | 6 |

2.8 Power connection layout

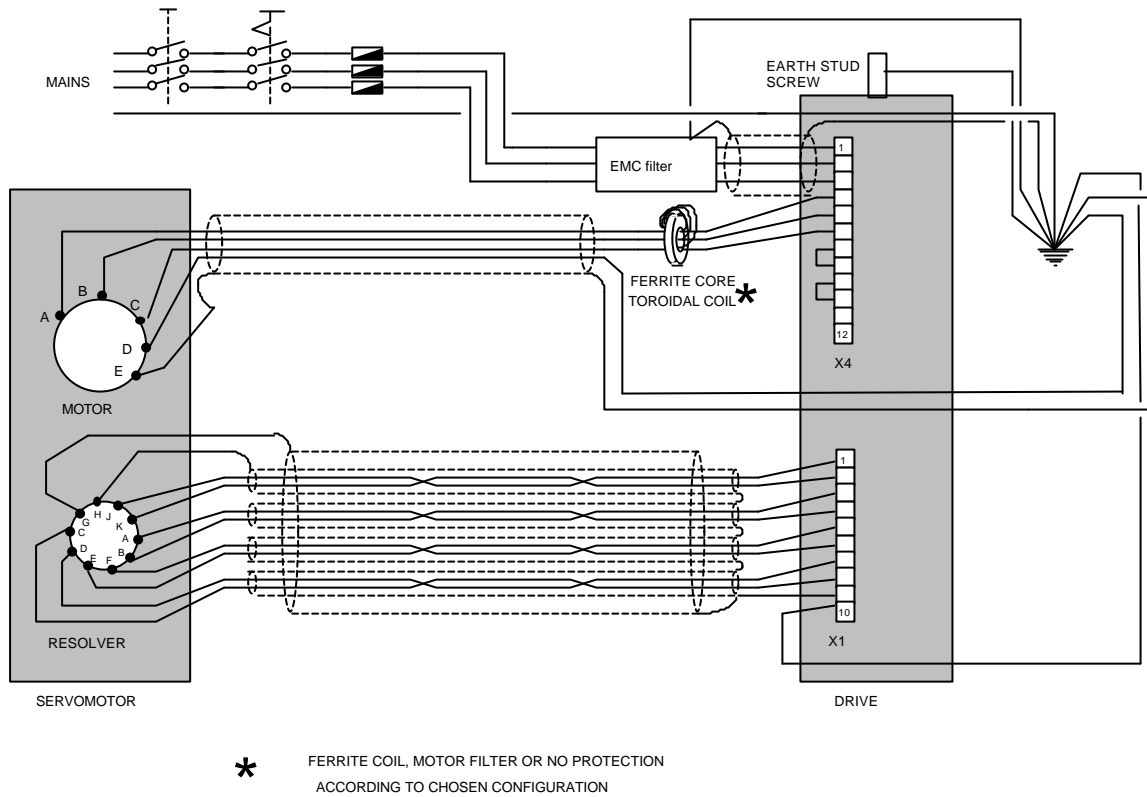

2.9 Signal cable connections

A twisted and shielded pair must be employed for the analogue reference.
The cable for emulated encoder signals must comprise three twisted pairs with a common shield.
Normal cables can be used for digital inputs/outputs.

Minimum size of all signal wires is 0.35mm²

2.10 Signal cable connection layout

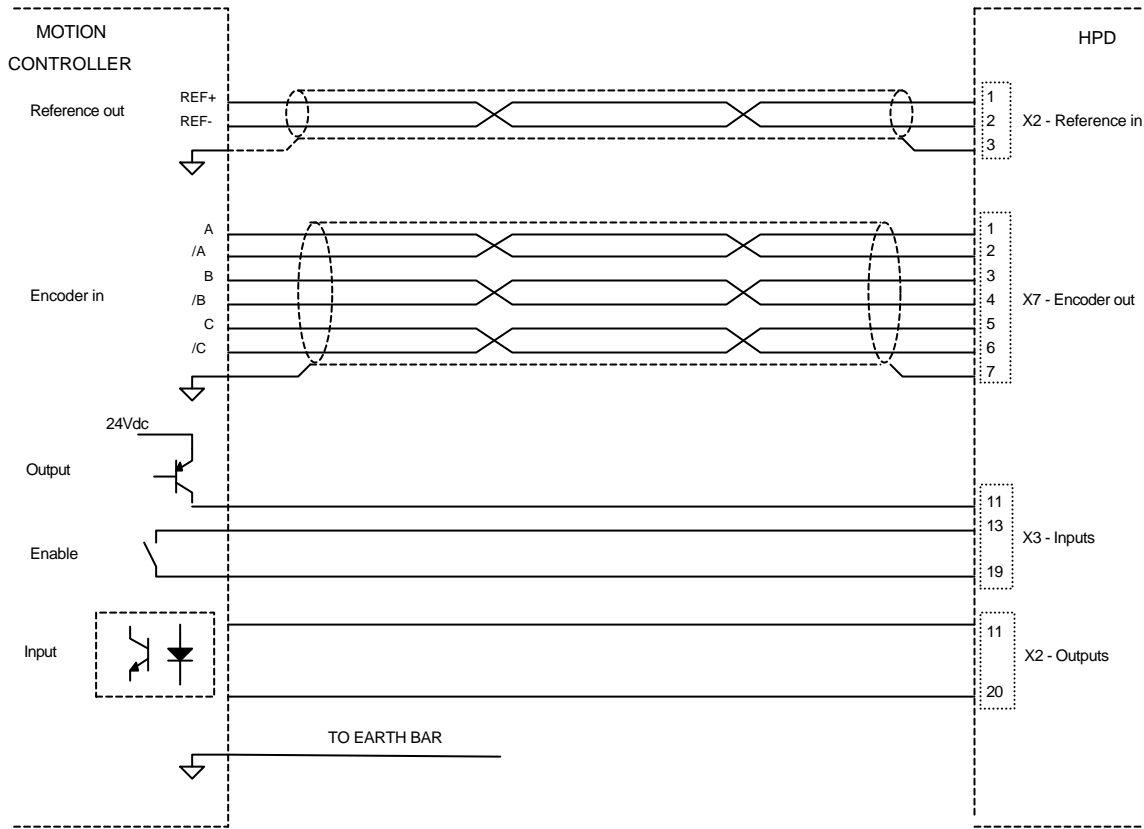

2.11 Frequency input connection

The RS-422 type frequency input can be software-configured in two modes: the first (default) to accept quadrature signals from encoders, the second is frequency/direction mode (see chapter *Basic parameters* bit b42.5).

In the former case follow this connection diagram:

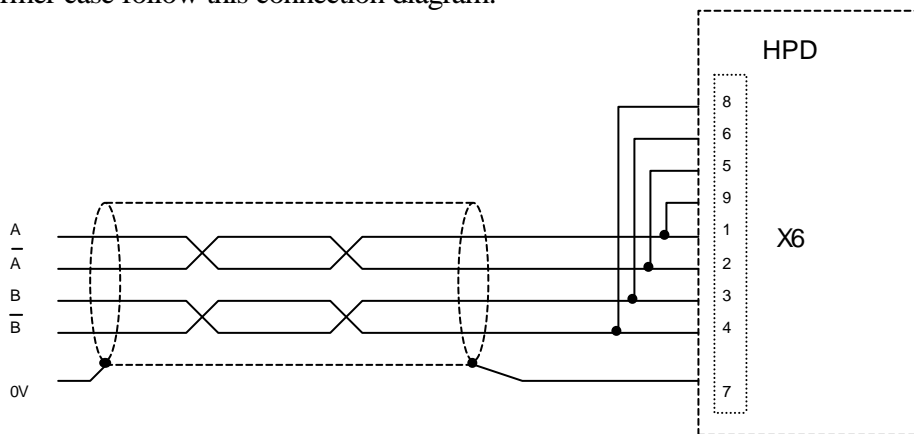

In the case of parallel connections to more than one HPD, connections to pins 9, 5, 6, and 8, must be made only on the last drive in the group.

If the frequency/direction mode configuration is adopted, channel A is dedicated to frequency while channel B handles direction. Frequently, a 24V interface is preferred to an RS-422 serial port. Using push-pull configuration, the conversion can be implemented on the external connector by following this wiring diagram:

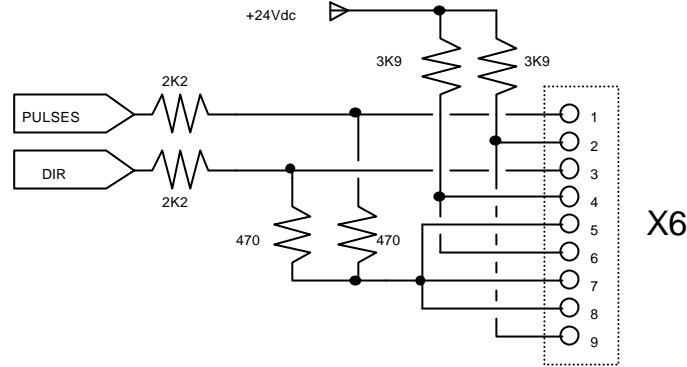

HPD connection with digital locking

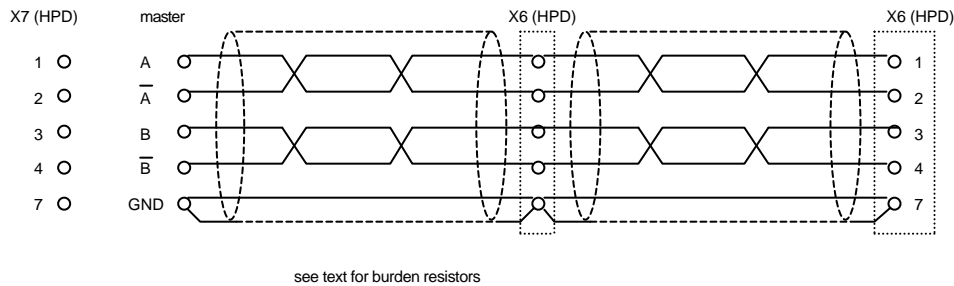

The example in the figure shows the connection between two HPD drives in digital lock with a master, but this configuration can be extended to several drives connected in series. On the final drive in the series connect the burden resistors by jumpering pin 1 with pin 9, pin 2 with pin 5, pin 3 with pin 6 and pin 4 with pin 8 on connector X6. The master can be an externally fed encoder, or the simulated encoder output on another drive.

The signal from the master encoder must be differential type 5V RS-422; it is therefore possible to connect a maximum of 10 slave HPDs.

If the master is an HPD drive, then up to 32 units can be connected in digital lock mode using the same simulated encoder signal (RS-422 standard).

For the relative programming of the HPD, consult the *Digital locking* chapter in this manual.

2.11.1 Encoder emulation

On connector X7 there are signals of encoder emulation phase A, phase B and phase C (reference zero). The signals are RS-422 type. For the relative programming of pulses per revolution consult the *Basic parameters* chapter in this manual, bit b42.0, b42.1 and b42.2 (default = 1024 pulses/revolution).

2.12 Serial line connection

The HPD drive serial line can be configured as RS-422 or RS-485 depending on the connection. In both cases termination resistors must be used (150Ω). Where more than one HPD drive is connected to the bus the final node must be terminated as shown below. The two cases are illustrated in the following diagrams.

RS-485

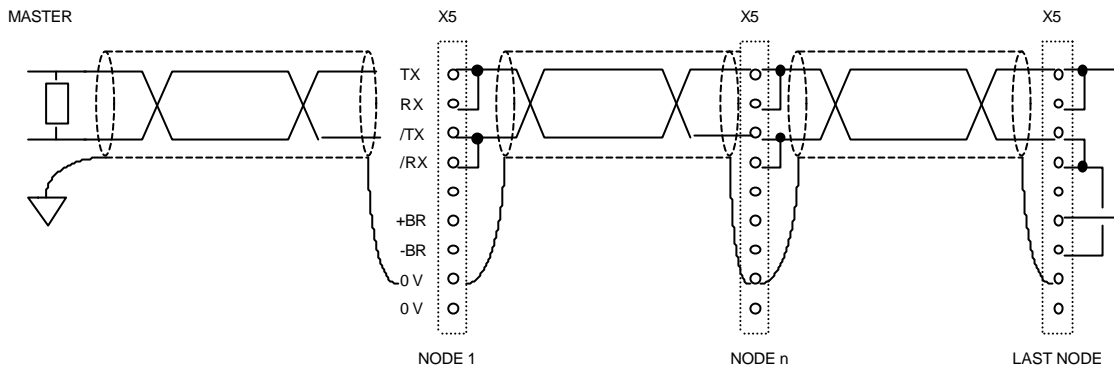

RS-422

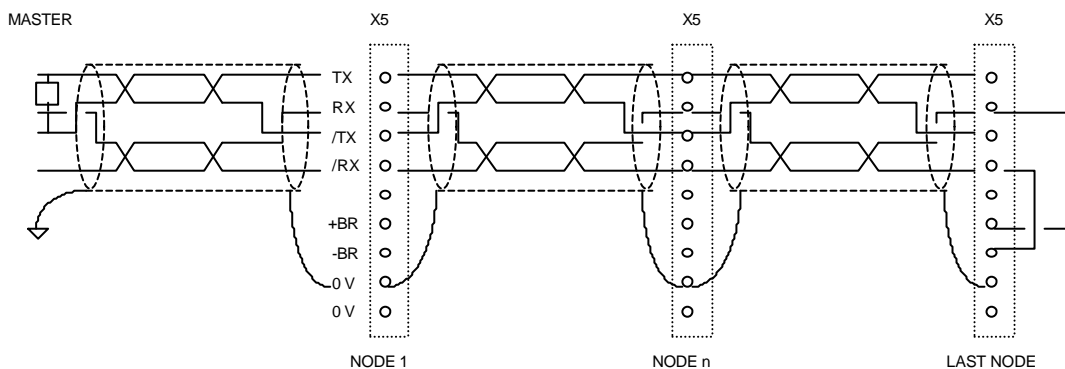

2.13 Braking resistor

HPD drives are equipped with an integrated braking resistor. The effective use of the braking resistor can be checked by monitoring the value of parameter Pr37, which is expressed as a percentage. If you intend to dissipate more power, use an external braking resistor. To connect up the system (which must be carried out in conditions of complete safety) disconnect the jumper between terminals 9 and 10 of terminal board X4; connect one end of the resistor to terminal 9 and the other to terminal 11 on X4. The external resistor value must be 40 ohm and a thermal magnetic circuit breaker must be installed between resistor and drive. The minimum wire size for the connection is 4 mm^2 ; the connection cables should be as short as possible and, in any event, no longer than 3 metres.

2.14 Backup

When you need to keep the drive electronics powered up during mains losses, for example to maintain the simulated encoder function, certain precautions are necessary.

- A) Use an external 24V d.c. 2 A power supply.
- B) Ensure that the drive is not started up with the backup voltage, which is only intended to maintain it in standby. To ensure this condition use the setup shown in the following figure.
- C) When mains voltage is restored the drive must not be enabled until 10 seconds have elapsed. When the mains fails the HPD will generate an undervoltage alarm; example 11 in the *Examples and applications* chapter indicates a method for resetting this alarm automatically ensuring a 10 second delay.

CONNECTION OF BACKUP POWER SUPPLY

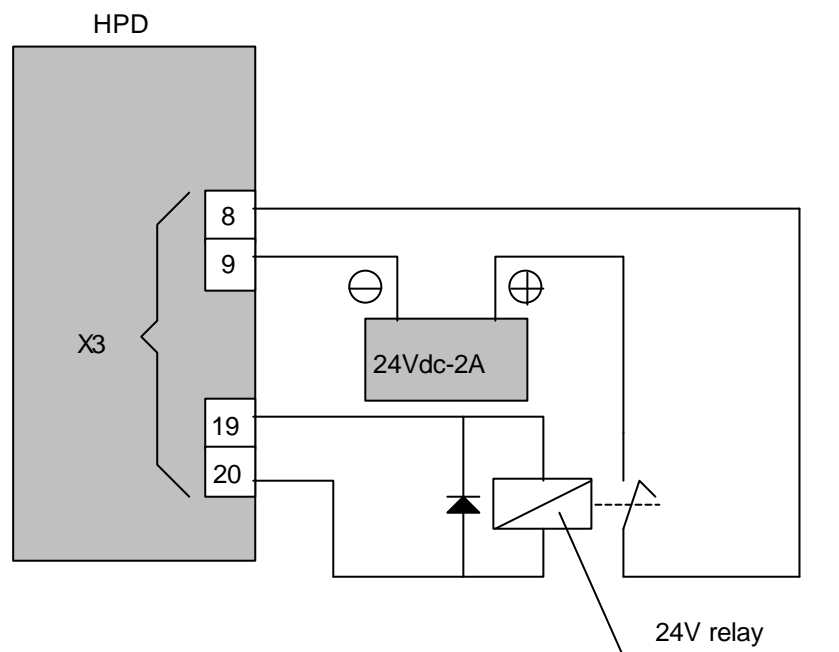

3 - PARAMETERS AND PROGRAMMING

The features: torque, speed, acceleration and position control are the task of a dedicated electronic circuits. In this chapter you can see how to set up and the meaning of any parameter, functional block diagrams and advanced functions description too.

In the figure below it is described the general block diagram of the drive's functions that you can configure by parameters.

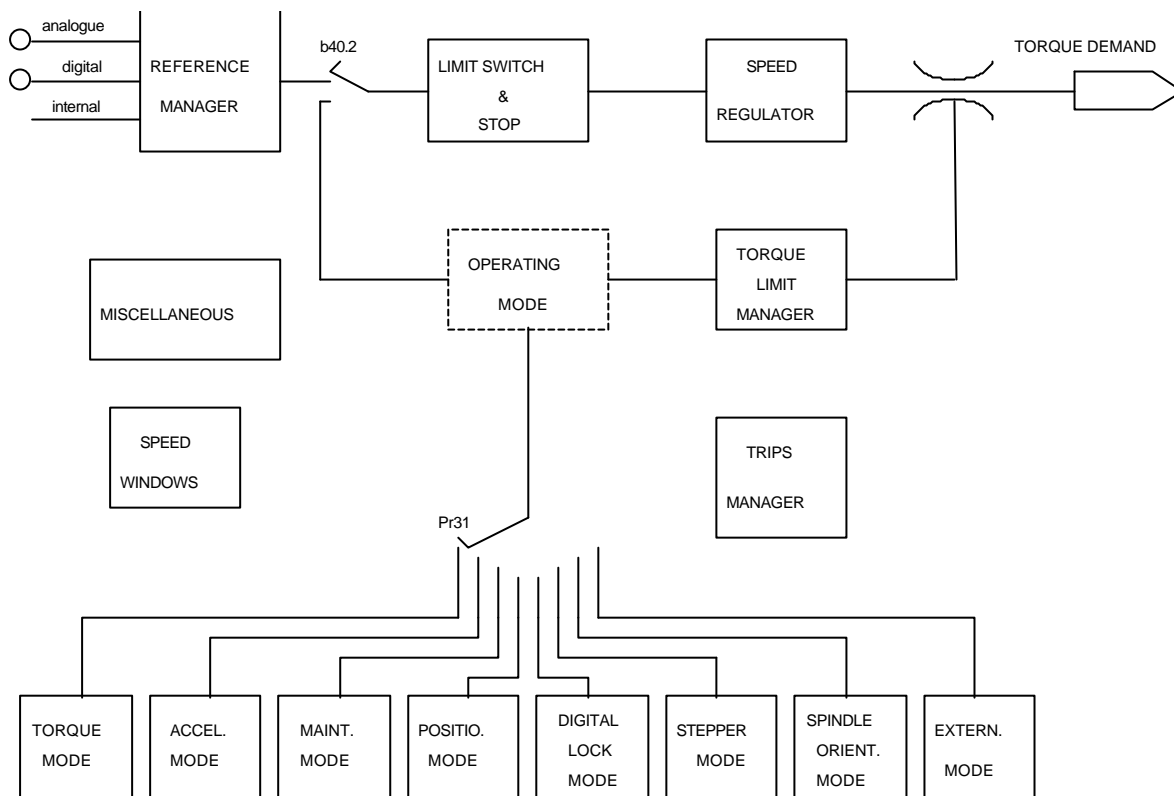

See chapter *Block diagrams* for a better description of how to use the drive, especially for operating modes. See chapter *Pico-PLC* to understand how to connect peripheral systems (inputs/outputs) to the parametric system of the HPD drive.

Parameters are divided as follows:

| | |
|-------------------|---------------------------|
| from Pr0 to Pb42 | basic parameters |
| from Pr50 to Pb70 | operating mode parameters |
| from Pr71 to Pb99 | pico-PLC parameters |
| from In0 to In63 | pico-PLC instructions |

The principal parameter units and resolutions are:

| parameter | unit | resolution |
|--------------|-----------------------------|-------------------|
| speed | revolutions per minute | 1 |
| acceleration | seconds / 1000 rpm. | 0.001 |
| position | 4096 steps / revolution | 1/4096 revolution |
| current | % of the drive peak current | 0.1 |

3.1 Using the keypad

The keypad-display module is designed to provide an intuitive operator interface. It can be used to program operating data, monitor system status and enter commands.

The module has only three keys, located at the top of the front panel just below the display. The keys are marked: [M], [+] and [-].

[M] is used to change the display mode and consequently also the function of [+] and [-].

There are two display modes: parameter mode and parameter value mode.

When the unit is powered up, provided there are no active alarms, the message “Idle” (drive disabled) or “run” (drive enabled) is displayed; this is also the position of parameter Pr0.

Press [+] or [-] to scroll through the parameters.

If you want to check a parameter value, press [M]; when the value is shown it can be updated using [+] and [-].

To return to parameter mode press [M] again.

The display can be shown in various forms, depending on the parameter in question.

If you need to increase (or decrease) a parameter value quickly, press [M] while the up key [+] (or down key [-]) is pressed.

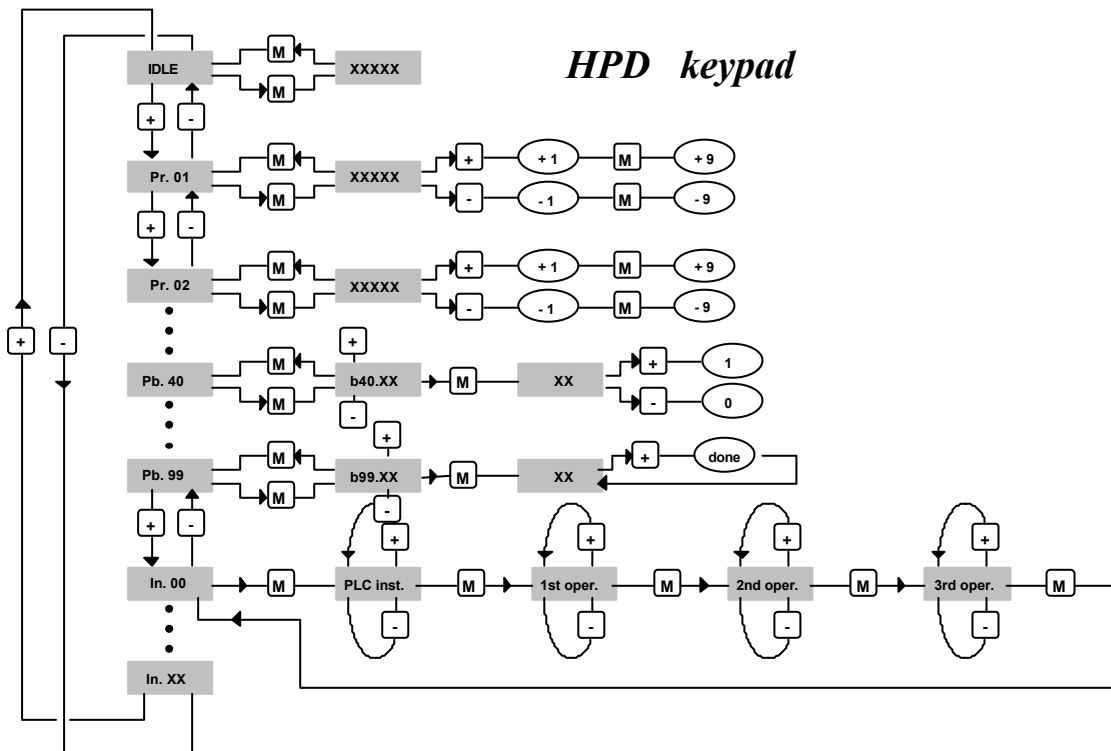

In addition to the parameter values and the pico-PLC instructions, the display may show the following messages:

- r. xx** At the time of power-up this message indicates the software version installed (2 seconds approx.).
- IdLE** At power-up and in correspondence with Pr0 this message shows that no alarms are present and the system is disabled.
- run** At the time of power-up and in correspondence with Pr0 this message indicates that no alarms are present and the drive is enabled; the motor shaft may be spinning.
- Er. xx** In correspondence with Pr0 this message indicates that the drive has detected an alarm (xx indicates the alarm code) and has therefore been disabled. When an alarm is detected the display automatically switches to parameter Pr0 and shows the alarm code.
- dcbuS** In correspondence with Pr0 this message indicates that the drive is not operating at low voltage (b40.10=0) and that DC bus voltage is still below the 120 V threshold; the inrush current circuit is still connected so the drive is not yet ready (b41.4=0).
- Prxx** Indication of parameter xx (value displayed by pressing "M").
- Pb. xx** Indication of bit parameter xx.
- bxx.yy** Indication of bit yy of parameter xx; press "M" to display bit status.
- In. xx** Indication of instruction xx of PLC program.
- donE** Displayed for approximately 1 second each time a command is entered.
- rESet** Displayed for approximately 1 second each time an alarm reset command is entered (b99.10).
- tESt** Displayed during wiring test (b70.3).
- rEtrY** It's displayed when a writing error is detected storing the pico-PLC instructions (b99.14) or while saving parameters (b99.15).

3.2 Commissioning the HPD drive

The steps described in this section must be followed carefully when the drive is started up for the first time.

- 1) Connect the motor to the drive in compliance with the wiring diagrams in the manual.
- 2) Make sure the drive is disabled (terminal 11 of board X3 must be open)
- 3) Power up the drive.
- 4) After some seconds the display shows "IdLE".
- 5) Setting essential parameters:
Pr33 calculation (rated current)

$$\text{Pr33} = \frac{\text{InM}}{\text{InD} \cdot 2} \cdot 100$$

where: InM is rated motor current at zero rpm in Ampere
 InD is rated drive current in Ampere
 The maximum value of Pr33 is 50.0

Pr19 calculation (peak current)

$$\text{Pr19}_{\text{MAX}} = \text{Pr33} \cdot 3$$

The maximum value must be no higher than three times the value of Pr33

Pr29 calculation (number of poles)

Use the following table for MB series motors

| <i>Flange (mm)</i> | <i>Pr29</i> |
|----------------------|-------------|
| 56 | 4 |
| 70 | 4 |
| 105 | 8 |
| 145 | 8 |
| 205 | 8 |

Pr32 calculation (rated speed)

If Pb 42.6=0 Pr32 = $V_{max} \cdot 1.12$

If Pb 42.6=1 Pr 32 = $\frac{\omega \cdot V_{MAIN}}{V_{MOT}} \cdot 8.3$

where: ω is nominal motor speed in rad/sec
 V_{main} is HPD power supply in Vrms
 V_{mot} is motor rated voltage in Vrms

Evaluation of Pr16 and Pr17 (speed regulator gain)

The default values of Pr16 and Pr17 have been chosen considering identical motor and drive rated currents; if this is not the case correct the values of parameters Pr16 and Pr17 with the ratio of the motor rated current/drive rated current. Preventive execution of this compensation will eliminate the risk of motor vibration at the first start-up.

- 6) Set the analogue reference signal to 0 V (terminals 1, 2 of board X2), and enable the drive (24 V on terminal 11 of board X3).
- 7) The motor shaft must be stopped; when the analogue reference voltage is changed motor speed should change proportionally. If this is not the case check your wiring.
- 8) Save your changes with b99.15.

The drive is preset with default values designed to meet the requirements of the majority of applications. With the default values the pico-PLC in the drive runs the program described in appendix G, so the following functions will be present on the input and output terminal boards:

| TERMINAL BOARD X2 | |
|-------------------|---------------------------------------|
| 11 | real speed > Pr13 |
| 12 | motor speed = reference (+/- 20 rpm) |
| 13 | real speed = 0 |
| 14 | real speed > 0 |
| 15 | motor thermal image active (i^2t) |
| 16 | |
| 17 | terminal A drive ready |
| 18 | terminal B (n.c. contact) |

| TERMINAL BOARD X3 | |
|-------------------|--------------------------------------|
| 11 | start drive |
| 12 | left-hand stroke end (n. c.) |
| 13 | right-hand stroke end (n. c.) |
| 14 | emergency stop (n. c.) |
| 15 | clockwise/counter-clockwise rotation |
| 16 | start / stop |
| 17 | |
| 18 | |

The functions on terminals 12, 13 and 14 must be enabled by setting bit b90.10 to one. This requires access to the extended parameters menu.

The default PLC program controls parameter Pr5 in addition to timer 1 (Pr92) and bits b40.0, b40.4, b40.5, b40.6, b40.12 so in this case the above binary parameters and switches cannot be utilised unless the pico-PLC is disabled (b99.13=0) or the basic program is modified.

Short and extended menu

When the HPD drive is in default status, only a limited number of parameters are displayed. These parameters are the only ones required for applications in which the HPD is employed as a straightforward frequency converter, i.e. you are not using the advanced functions of the drive (e.g. using HPD with a Numerical Control or an intelligent axis control card). Switch between short and extended menu using b99.6.

Short memory parameters are:

- Pr0 Real speed of motor shaft in rpm.
- Pr1 Analogue reference offset (terminals 1 and 2 of terminal board X2).
- Pr2 Analogue reference full scale: speed value in rpm corresponding to 10 V reference signal.
- Pr8 Acceleration/deceleration ramp values in seconds per 1000 rpm
- Pr16 Integral gain of speed control loop.
- Pr17 Speed control loop damping.
- Pr19 Peak current delivered to drive expressed as a percentage of the peak rated value of the drive.
- Pr29 Number of motor poles.
- Pr32 Rated speed (rpm).
- Pr33 Rated current that can be delivered by the drive (can be maintained indefinitely) expressed in percent of the peak rated current of the drive.
- Pr35 Instantaneous current requested by the motor expressed as a percentage of drive peak rated current.
- b99.6 Enable extended menu. Default=0. Set to 1 to obtain the extended menu.
- b99.7 Security. Default=0. Set to 1 to protect parameters from modification.
- b99.10 Alarm reset command.
- b99.13 PLC status. Default=1. At 1 the PLC program is executed, at 0 the program is not executed.
- b99.15 Parameter storage command.

Using extended menu you can manage all parameters and pico-PLC instructions.

Restoring default parameters

- If you need to restore the factory-set default parameter values:
- disable the drive via hardware (open terminal 11 on board X3)
 - power-up the system
 - the display will show "IdLE" after approximately 3 seconds
 - set b99.7 and b99.13 to zero
 - enter command b99.12
 - save your changes with b99.14 and b99.15.

3.3 Basic parameters

To access all the following parameters open the extended menu by setting b99.6 to one. For this procedure, b99.7 must be set to zero.

DECIMAL PARAMETERS

- Pr0** **Motor speed:** this is a read-only parameter expressed in rpm; the message Pr0 never appears on the display. In its place a message corresponding to drive status is shown.
- Pr1** **Analogue reference offset.** This is expressed in input A/D converter counts. Programming limits are -10000 and +10000 while the range of the A/D converter is from -16384 to +16383 over ± 10 V.
- Pr2** **First full scale of analogue reference.** Unit=rpm, range= ± 10000 , default=3000. If b40.0=0 and b40.12=0, Pr7 will be equal to: $V_{in} \cdot Pr2 / 9.76$ where V_{in} is the voltage on the analogue input.
- Pr3** **Second full scale of analogue reference.** Unit=rpm, range= ± 10000 , default=-3000. If b40.0=1 and b40.12=0, Pr7 will be equal to: $V_{in} \cdot Pr3 / 9.76$ where V_{in} is the voltage on the analogue input.
- Pr4** **Frequency reference full scale** (connector X6). Unit=rpm, range= ± 32767 , default=3000. If b40.12=1 and b40.13=1, Pr7 will have the following value:
 if b42.5=0 $Pr7 = Fin \cdot Pr4 / 2000000$ (frequency/direction signal)
 if b42.5=1 $Pr7 = Fin \cdot Pr4 / 500000$ (quadrature signal)
 where Fin is the frequency on the encoder input.
- Pr5** **Internal reference.** Unit=rpm, range= ± 9000 , default=0. If b40.12=1 and b40.13=0, Pr7 will be the same as Pr5.
- Pr6** **Reserved read-only speed reference.** Unit=rpm, range= ± 9000 . If b40.2=1 Pr6 is only utilised as a speed reference for the control loop. The active operating mode will enter its speed request in parameter Pr6.
- Pr7** **Main reference** (read-only parameter). Unit=rpm, range= ± 9000 . If b40.2=0, Pr7 is used as a reference for the speed control loop. In certain operating modes Pr7 can be used as a reference for other factors (torque / acceleration). In this case Pr7 is expressed in a suitable unit.
- Pr8** **Acceleration ramp for positive speed values.** Unit=s/krpm range=0.002..65.535, resolution=0.001 s, default=0.002 s. Acceleration for positive speeds required of the motor by way of the speed reference is internally limited so that acceleration of 1000 rpm takes Pr8 seconds.
- Pr9** **Deceleration ramp for positive speed values.** Unit=s/krpm, range=0.002..65.535, resolution=0.001 s, default=0.002 s. Deceleration for positive speeds required of the motor by way of the speed reference is internally limited so that deceleration of 1000 rpm takes Pr9 seconds.
- Pr10** **Acceleration ramp for negative speed values.** Unit=s/krpm, range=0.002..65.535, resolution=0.001 s, default=0.002 s. Acceleration for negative speeds required of the motor by way of the speed reference is internally limited so that acceleration of 1000 rpm takes Pr10 seconds.
- Pr11** **Deceleration ramp for negative speed values.** Unit=s/krpm, range=0.002..65.535, resolution=0.001 s, default=0.002 s. Deceleration for negative speeds required of the motor by way of the speed reference is internally limited so that deceleration of 1000 rpm takes Pr11 seconds.

- Pr12 Deceleration ramp for stroke end and stop functions.** Unit=s/krpm, range=0.002..65.535, resolution=0.001 s, default=0.002 s. Deceleration required of the motor by the stroke limit and stop functions is internally limited so deceleration of 1000 rpm takes Pr12 seconds.
- Pr13 Overspeed threshold.** Unit=rpm, range=0..+13000, default=3500. If the absolute value for motor speed exceeds the value entered in Pr13, b41.0 must be =1, otherwise it will be = 0.
- Pr14 High speed threshold.** Unit=rpm, range= \pm 13000, default=20. When b40.7=0, if the speed difference between motor and reference is less than Pr14 and greater than Pr15, b41.1 will be =1, otherwise it will be = 0. In the case of b40.7=1, if motor speed is less than Pr14 and higher than Pr15, b41.1 will be =1, otherwise it will be =0.
- Pr15 Low speed threshold.** Unit=rpm, range= \pm 13000, default=20. When b40.7=0, if the speed difference between motor and reference is less than Pr14 and greater than Pr15, b41.1 will be =1, otherwise it will be =0. In the case of b40.7=1, if motor speed is less than Pr14 and higher than Pr15, b41.1 will be =1, otherwise it will be =0.
- Pr16 Integral gain of speed control loop.** Range =0...32767, default=120.
- Pr17 Speed control loop damping.** Range=0...32767, default=2000. If Pr16 is set to zero Pr17 sets the value for proportional gain of the speed control loop.
- Pr18 Bandwidth limiter.** Unit=512 μ s, range=0..1000, default=1. Use Pr18 to set the time constant of a first order filter located on the digital torque demand signal. The filter cut-off frequency will be: 310/Pr18 Hertz.
- Pr19 Peak current.** Unit=%, range=0..100.0%, resolution=0.1%, default=100.0%. Maximum current that the drive can deliver to the motor expressed as a percentage of drive peak current. It is good practice to maintain this value to within 3 times the rated motor current.
- Pr20 DC bus voltage.** Unit=volt, read-only parameter. Shows the value of DC bus voltage.
- Pr21 Torque limiter,** read-only parameter. Unit=% . Can be used by operating modes to restrict motor torque.
- Pr22 Auxiliary analogue reference.** Unit=% . The displayed value will be Pr22=Vin·100/9.76. Resolution is 0.2%.
- Pr23 Alarm code.** This code shows the currently active alarm; zero means that no alarms are active. Consult the table of alarm codes for more details.
- Pr24 Last alarm.** This parameter stores the last alarm. Pr24 is reset when the alarm reset command is entered (b99.10).

| Alarm code | Alarm |
|------------|----------------------------------|
| 0 | no alarm |
| 1 | overvoltage |
| 2 | undervoltage |
| 3 | overcurrent |
| 4 | resolver alarm |
| 5 | motor overheating |
| 6 | drive overheating |
| 7 | external alarm |
| 8 | auxiliary alarm |
| 9 | digital output overcurrent alarm |
| 10 | PLC check-sum |
| 11 | parameter check-sum |

- Pr25 Code describing installed software version.** Read-only parameter.
- Pr26 Serial line baud-rate code.** Default=8. This is the code for programming transmission speed. For more information consult the section on the serial interface.
- Pr27 Serial line address code.** Default=0, possible settings=0..31. For more information consult the relative section of the manual.
- Pr28 Motor shaft position.** Unit=steps, range=0..4095. Read-only parameter that shows the absolute position of the resolver.
- Pr29 Number of motor poles.** Possible settings=2..64, default=8.
- Pr30 Resolver position offset.** Default=0; use Pr30 for electronic correction of the mechanical resolver position.
- Pr31 Operating mode.** Default=0. Use Pr31 to select the active operating mode. 0 indicates no operating mode.
- Pr32 Rated speed.** Unit=rpm, range=0..9000, default=3200. Nominal motor speed. Should be programmed with the motor speed at which rated voltage corresponds to drive power feeding voltage reduced by 13%. Consult the formula in section *Commissioning the HPD drive*.
- Pr33 Motor rated current.** Unit=% of peak current, range=10.0..50.0%, resolution=0.1% default=50.0%. Enter motor rated current.
- Pr34 Tacho generator emulation output gain.** Default=127. Use parameter 34 to alter analogue output gain in proportion to speed (terminal 9 on board X2). The analog output value (Volt) is:
- $$tacho = \frac{Pr\ 0 \cdot Pr\ 34}{K \cdot 15875} \quad \text{where: } \begin{array}{ll} K = 1 & \text{if } Pr32 \leq 875 \\ K = 4 & \text{if } 875 < Pr32 \leq 3500 \\ K = 16 & \text{if } Pr32 > 3500 \end{array}$$
- Pr35 Torque monitor.** Unit=% of peak torque, resolution 0.1%. This parameter indicates the percentage of torque (or current) that the motor is delivering.
- Pr36 Thermal image of motor winding.** Unit=% of reference temperature. This read-only parameter indicates an estimation of the heat on the innermost windings of the motor. If the value reaches 100.0 %, which is equal to the nominal value, b41.11 switches to 1 so that current can be limited to the rated value.
- Pr37 Thermal image of braking resistor.** Unit=% of nominal temperature. This read-only parameter indicates an estimation of the heat on the braking resistor. If the value reaches 100.0 % or more, consider using an external braking resistor.
- Pr38 Auxiliary analogue output.** Unit=% of 9.76V, default=0, range=±100.0%, resolution 8 bit. If b40.11 is equal to 1, the auxiliary analogue output will be equal to 976·Pr38/100 volts.
- Pr39 Phase correction.** This parameter may be used in certain applications with special motors that are to run also at constant power. Range ±32000, default = 0.

BINARY PARAMETERS

Binary parameter Pb40 can be read, written and saved. Binary parameter Pb41 provides information regarding system status. Parameters Pb42 and Pb99 are read/write parameters with save facility.

- b40.0 Selecting the first or second speed reference full scale value.** Default=0. If set to 0 Pr2 is used to standardise the analogue reference. If set to 1 parameter Pr3 is used.

- b40.1 Activation of algorithm for the suppression of vibration at 0 rpm.** Default=0. Set to 1 to activate the algorithm.
- b40.2 Selecting user/reserved reference.** If set to 1 the reserved reference is used in accordance with the currently active operating mode. If set to zero the reference selected by b40.0, b40.12 and b40.13. is employed. Default is 0.
- b40.3 Reference freeze.** Default=0. If set to 1 the reference will not be updated so that motor will not follow input reference modifications. If set to zero the reference will follow variation in the input reference.
- b40.4 Left-hand stroke end.** Default=0. If set to 1 and the selected reference requires negative speed, the reference will be forced to zero in accordance with the ramp in Pr12. If set to zero no type of control is performed.
- b40.5 Right-hand stroke end.** Default=0. If set to 1 and the selected reference requires positive speed, the reference will be forced to zero in accordance with the ramp set in Pr12. If set to zero no control is performed.
- b40.6 Stop function.** Default=0. If set to 1 the motor is stopped according to the ramp set in Pr12.
- b40.7 Absolute/relative speed window selection.** Default=0. If set to zero speed windows Pr14 Pr15 b41.1 will operate in relative mode, if set to 1 the speed windows will operate in absolute mode.
- b40.8 Analogue torque limit.** Default=0. If set to 1, Pr22, i.e. auxiliary analogue input, will be used to limit motor torque.
- b40.9 Software enable.** Default=1. If set to zero the drive cannot be started.
- b40.10 Low voltage operation enable.** Default=0. If at 1 the inrush current circuit will be connected each time the drive is disabled, thus permitting rapid increases in power supply voltage. When the drive is started the inrush current circuit will be connected before the effective start-up of the power stage. This procedure causes a drive start-up delay of 120ms.
- b40.11 Analogue output selector.** Default=0. If set to 0 the analogue output will carry a signal proportional to motor torque. If set to 1 it carries a value proportional to Pr38.
- b40.12 Digital/analogue reference selector.** Default=0. If set to 0 the analogue input is selected as the main reference. If set to 1 the reference will be digital and, by means of 40.13, it can be set for internal or external. If set for an external input, using b42.5 this can be set for quadrature or frequency/direction.
- b40.13 Internal or frequency reference selector.** Default=0. If b40.12=1, b40.13 can be set to 0 to select internal reference, or to 1 to select the frequency input (encoder-in) which, in turn can be configured as frequency/direction or quadrature signal using b42.5.
- b40.14 Serial communication enable.** Default=0. Set this parameter to 1 to enable serial comms.
- b40.15 Reserved.** Must remain on zero.
- b41.0 Overspeed.** When the absolute motor speed value exceeds the value set in Pr13, b41.0 is on 1, otherwise it is on 0.
- b41.1 At speed.** With b40.7=0 if the speed difference between motor and reference is lower than Pr14 and higher than Pr15, b41.1 will be 1, otherwise it will be 0. With b40.7=1, if motor speed is lower than Pr14 and higher than Pr15, b41.1 will be 1, otherwise it will be 0.
- b41.2 Zero speed.** If motor speed (Pr0) is zero rpm, b41.2=1, otherwise b41.2=0.
- b41.3 Forward.** If motor speed (Pr0) is positive b41.3=1, otherwise b41.3=0.
- b41.4 Drive Healthy.** If =1 no alarms are present, otherwise =0.
- b41.5 Hardware enable status.** 1 when hardware enable is set.

- b41.6 Temperature pre-alarm.** 10 degrees before reaching the maximum temperature of the power stage, b41.6 is set to 1.
- b41.7 External alarm.** Alarm for user's equipment.
- b41.8 Auxiliary alarm.** Second alarm for user's equipment.
- b41.9 Calibration failed.** b41.9=1 indicates that initial calibration of current offsets has terminated incorrectly.
- b41.10 Speed control saturation.** b41.10=1 when the speed control loop is delivering maximum current.
- b41.11 I²T active.** Indicates that Pr36 has reached 100.0 % and therefore the drive is restricting current to the rated value.
- b41.12 Drive enabled**
- b41.13 Keypad fault.** b41.12=1 if communication between keypad and drive has failed.
- b41.14 External operating mode.** If set to 1 an external operating mode is installed.
- b41.15 External operating mode time slot.** If set to 1 indicates that the external operating mode is controlled at 2 ms intervals otherwise at 512µs.

- b42.0** Selector to configure encoder emulation.
- b42.1** Selector to configure encoder emulation.
- b42.2** Selector to configure encoder emulation.

| | |
|--|---------------------------------------|
| Pr32 up to 9000 rpm Pr32 up to 3500 rpm Pr32 up to 875 rpm | ===== |
| ENCODER OUT | ===== |
| | 16384 8192 4096 2048 1024 512 256 128 |
| b42.0 | 0 1 0 1 0 1 0 1 |
| b42.1 | 0 0 1 1 0 0 1 1 |
| b42.2 | 0 0 0 0 1 1 1 1 |

the double line indicates encoder resolutions available in the various speed ranges
Default value is 1024

- b42.4 24V over current.** Digital output trip.
- b42.5 Frequency input** (board X6). If set to 1 the frequency input is programmed to receive two phases in quadrature. This is the default. If set to 0 it is enabled to receive a frequency/direction type input.
- b42.6 Torque compensation.** Default=1. When set to 1 torque compensation is implemented to improve linearity of response.
- b42.7** Reserved.

- b99.6 Extended menu enable.** Default=0. Set to 1 to enable the extended menu.
- b99.7 Security.** Default=0. Set to 1 to prevent parameter modification.
- b99.13 pico-PLC status.** Default=1. If on 1 the PLC program is run, if on zero the program is not run and the PLC instructions can be modified if required.

3.4 Basic commands

To transmit the following commands b99.7 must be on zero. For commands b42.3 and b94.1, b99.6 must be on one.

- b42.3 Re-initialise serial line.** Command to reinitialise the serial line when the communication speed (Pr26) has been modified. In any event, the serial line is initialised when the drive is started up.
- b94.1 Reset main reference offset.** This command automatically sets parameter Pr1 in order to reset any voltage offset on the main analogue reference. This procedure is only possible if the absolute offset value is less than 200 mV.
- b99.9 Current offset calibration request.** The command is accepted only if the drive is disabled. The calibration procedure is executed when the drive is started up.
- b99.10 Alarm reset.** This command resets Pr23 and Pr24; if the alarm persists it is shown on the display. The command is not accepted in the presence of checksum errors (Pr23=10, 11); in this case set default parameters (b99.12) and then reset the alarm.
If the backup power supply is present (terminals 8 and 9 on X3), when mains power is restored to the terminals on X4 you must wait 10 seconds before transmitting the undervoltage alarm reset command and enabling the drive.
- b99.11 Operating mode parameter default values.** This command sets current operating parameters to default values. The command is executed only if b40.2 = 0.
- b99.12 Default values.** This command sets all parameters to default values and cancels the values used by the operating modes; it also sets the pico-PLC program as described in appendix G. If a checksum alarm is present, Pr23 and Pr24 are set to zero so that the alarm can be reset. The command is executed only if b99.13 = 0.
- b99.14 Save pico-PLC instructions.** Saves the pico-PLC program. If an error occurs while saving, "retry" is shown on display: in this case transmit the command again.
- b99.15 Save parameters.** Stores all parameters. This command is not possible in the presence of a checksum error; in this case, set default parameters, reset the alarm and then save the new parameterisation settings. If an error occurs while saving, "retry" is shown on display: in this case transmit the command again.

3.5 Calibrating speed loop

IMPORTANT CONCEPTS

SPEED LOOP: the main task of any drive is to control motor speed so that it follows, as faithfully as possible, the required speed, which is generally referred to as the **REFERENCE**. High fidelity reproduction of the reference implies that motor speed is identical to reference speed in static conditions and also that it follows speed requirements closely also in the case of sudden changes in the speed reference (dynamic conditions). To perform this task the drive must be informed of various characteristics of the motor and the mechanical system to which the motor is coupled; this type of information is set in the **CALIBRATION PARAMETERS**.

ERROR: the error refers to the difference between reference speed and motor speed. The error value is utilised by the speed control loop to calculate (using calibration parameters) how much current to supply to the motor.

TORQUE: current flowing through the motor windings is converted into torque which allows the motor to accelerate and decelerate.

GAIN: in consideration of the typical applications of the HPD drive, the expression “gain” in this section of the manual refers to “stiffness”. To understand the concept of stiffness imagine a motor controlled by a drive with speed demand of zero rpm. The motor shaft will appear immobile but if we apply torque to the shaft it will rotate through an angle that depends on the amount of torque applied. We can then apply the rated torque of the motor and then measure the “stiffness angle” in degrees. The resulting value provides an indication of the fidelity of the drive thus parametrised, although it is clearly not the only fidelity indicator.

WHAT'S NEEDED

To calibrate an HPD drive correctly we recommend using an oscilloscope with memory. Obviously, the technician in charge must be well versed in the use of the instrument. If it is impossible to use an oscilloscope, we illustrate, at the end of this section of the manual, an alternative although less accurate method.

BEFORE STARTING

Before starting observe figure 1.

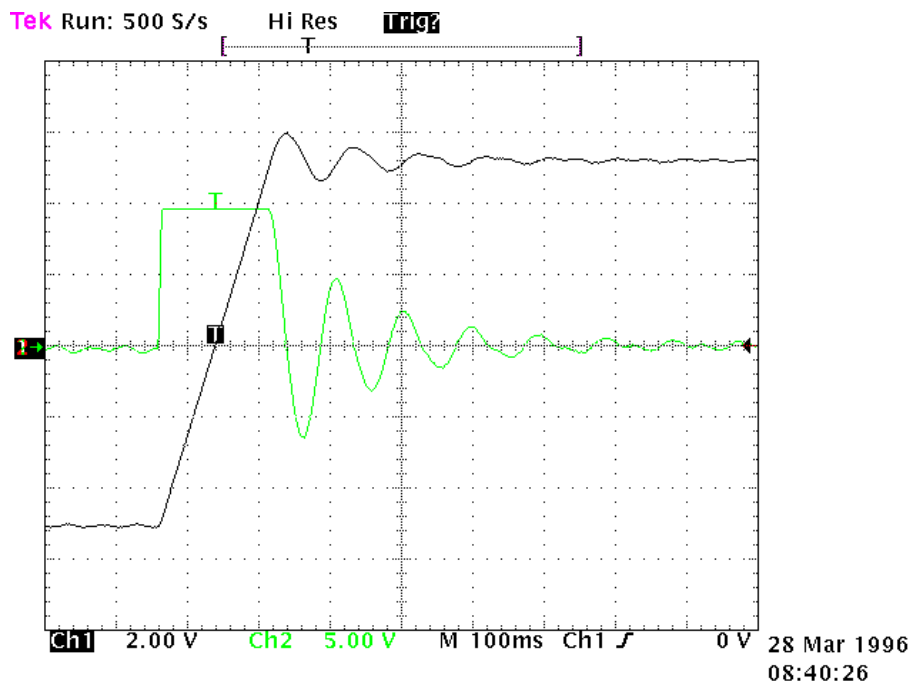

Fig. 1

The graph shows system response to a square wave speed reference. Channel 1 (Ch1) is speed and channel 2 (Ch2) is motor current. The channel 1 oscilloscope probe is connected to terminal 9 of X2 and channel 2 to terminal 7 of X2. The V/div scale and the timebase are not mentioned as they may vary considerably.

CALCULATING Pr16

The value of Pr16 should be calculated before enabling the drive. Pr16 defines system gain. To convert Pr16 into degrees for rated torque use the formula: $a_c = \frac{Pr\ 33}{Pr\ 16} \cdot 28$ where a_c is the stiffness angle. Obviously, before the formula can be used Pr33 must be set to motor rated current. To evaluate a_c correctly we shall consider that, if the driven machine transmission is rigid (not flexible) and there is no transmission backlash, the optimal stiffness angle could be around 4 degrees. If the transmission is not sufficiently rigid it may be necessary to reduce gain. If motor torque has been selected to achieve steep acceleration ramps, while dynamic torque changes in normal operation are minimal, stiffness angles of 20, 30 or 40 degrees are acceptable without negatively affecting performance. If you encounter difficulty in choosing the most appropriate stiffness angle, start from 10 degrees, which is the default value when using a motor with the same rated current as the drive.

Now enter the calculated value for Pr16 and start the motor with a square wave reference signal (pay attention when setting the reference amplitude and frequency to avoid problems in the case of limited stroke axes). On the oscilloscope note that the response changes as Pr17 is altered. Lowering Pr17 will allow you to approach system response as shown in figure 2.

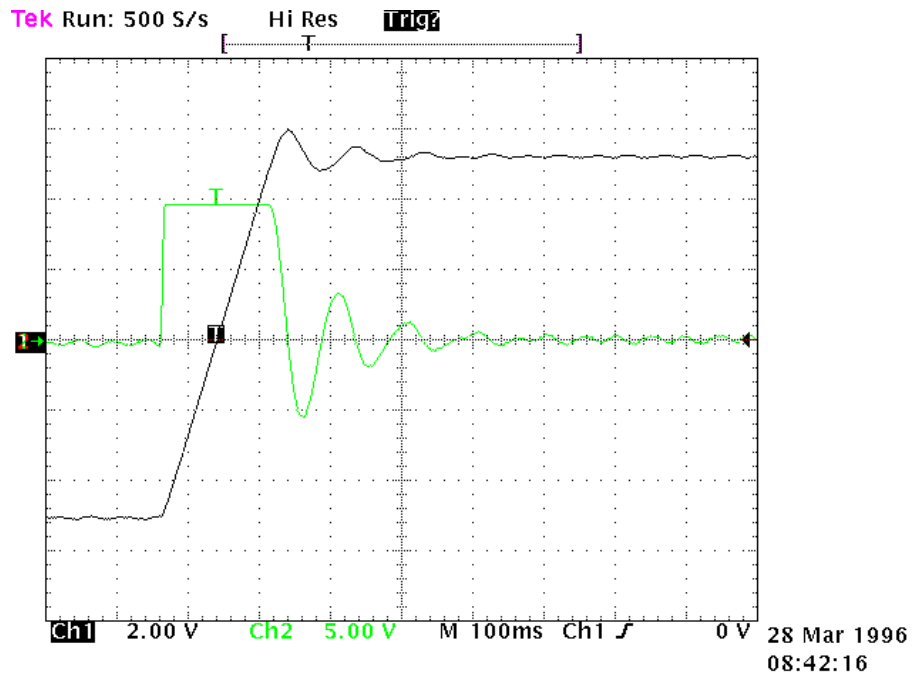

Fig.2

For higher values of Pr17 system response will resemble the situation of figure 3 below.

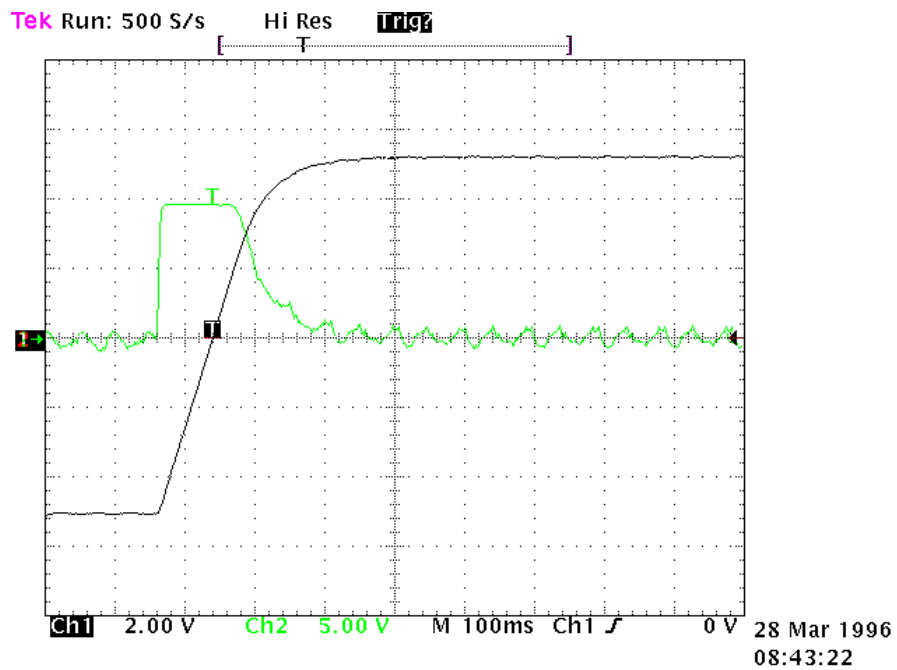

Fig.3

The optimal value of Pr17 can be considered when system response is as shown in figure 4.

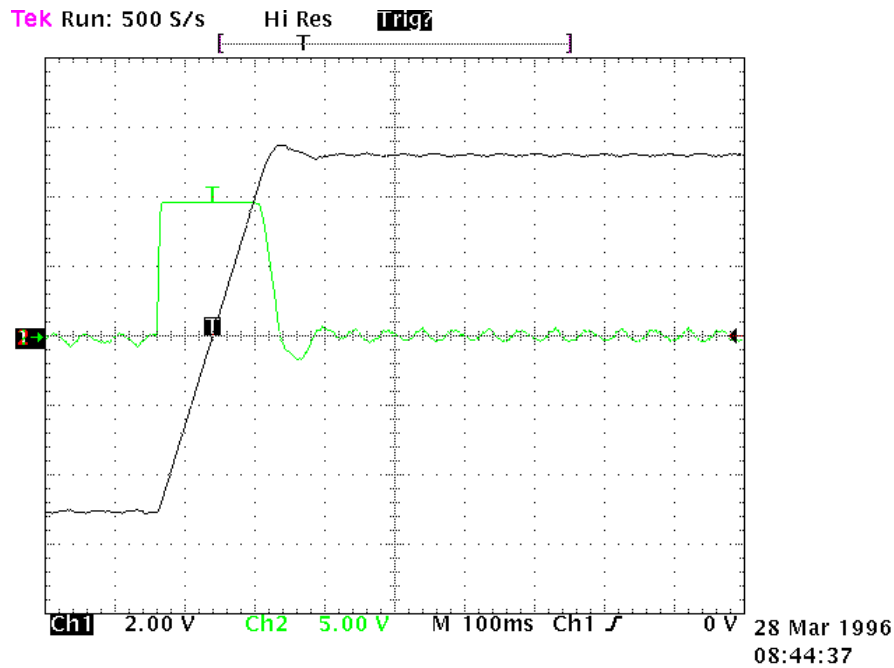

Fig.4

We must therefore obtain approximately 10% overshoot. Make sure that the overshoot is not followed immediately by undershoot.

Once you have set the optimal value for Pr17 pay attention to the movement of the motor shaft: if it moves smoothly without vibration and noise, you can deduce that system calibration procedures are terminated. Otherwise repeat all the previous steps using lower values for Pr16.

In certain applications you can reduce system acoustic noise levels by raising parameter Pr18 by a few points. Fig.5 shows that the optimal system response is accompanied by a current fluctuation that can generate acoustic noise and mechanical vibration; increasing Pr18 to the value 3 will improve this condition significantly (fig. 6).

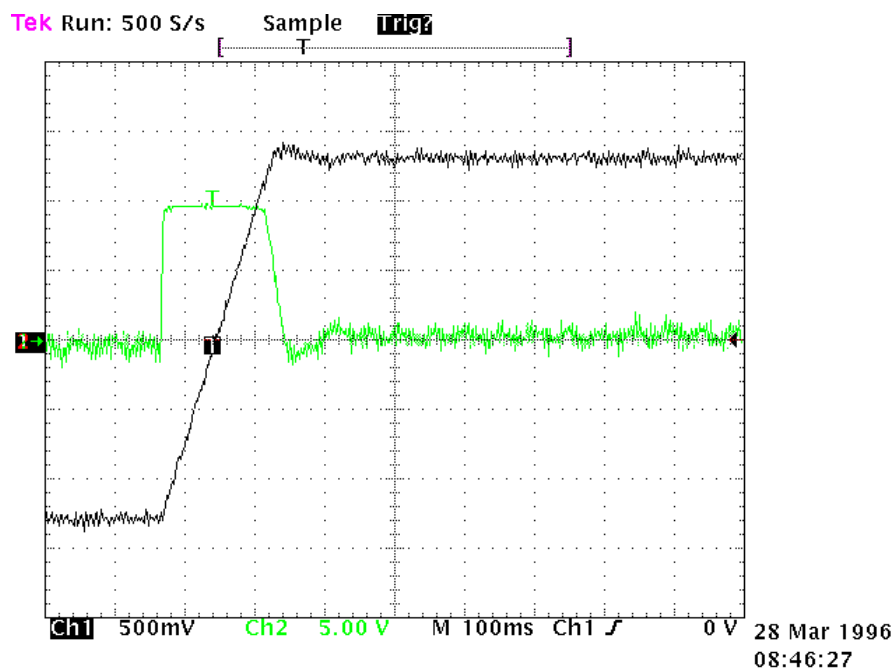

Fig.5

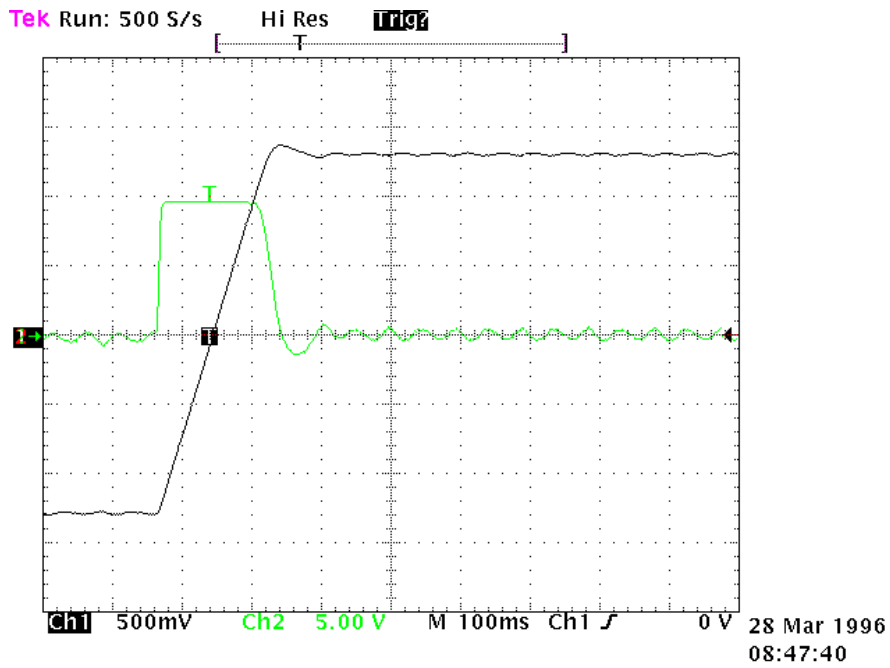

Fig.6

If the driven mechanical system is prone to oscillation, we recommend using very low values for Pr16; in this configuration the HPD drive will smooth out motor torque requests to prevent the creation of mechanical oscillation. Figure 7 shows this type of configuration.

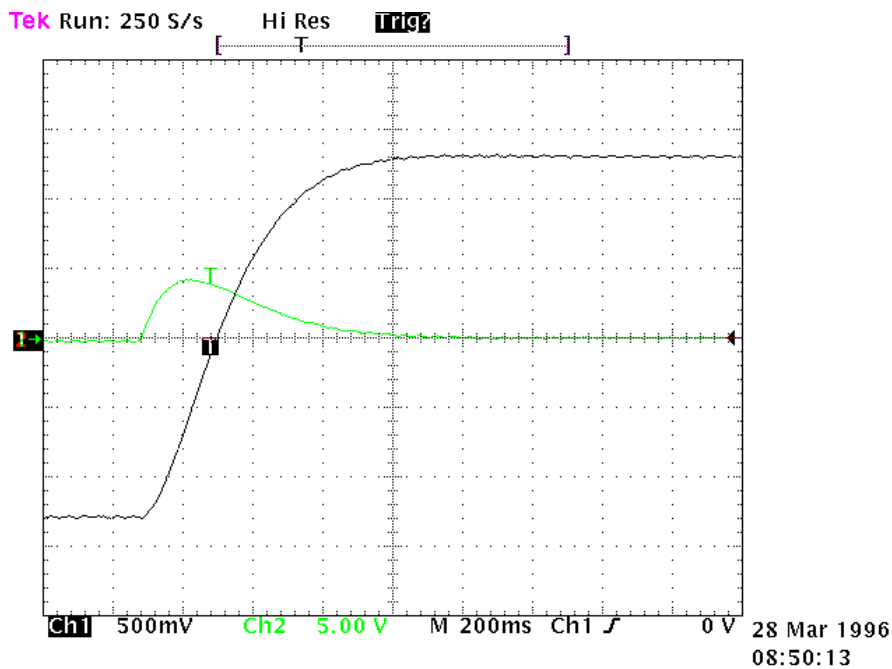

Fig.7

CALIBRATION WITHOUT INSTRUMENTS

If an oscilloscope is not available, proceed as follows:

- A) Calculate the value of Pr16 as described earlier.
- B) Calculate Pr17 using the following formula:

$$\text{Pr17} = 1488 \cdot \sqrt{\frac{135.41 \cdot \text{Pr16} \cdot J_{\text{tot}}}{\text{Nm}_{\text{peak}}}}$$

where: J_{tot} is total inertia (motor + load) in kgm^2

Nm_{peak} is available torque with peak current of the system

- C) Start the drive and, moving the axis with an external control change Pr17 to seek the value at which the axis moves as required.
- D) Calculate Pr18 using the following formula:

$$\text{Pr18} = 0.17 \cdot \frac{\text{Pr17}}{\text{Pr16}} \geq 1$$

If the resulting calibration is unsatisfactory, repeat the procedure with lower values for Pr16.

3.6 Operating modes

Operating modes are selected by means of parameter Pr31, whose default value is 0. Each operating mode commands a speed loop by means of parameter Pr6 and can limit motor torque with parameter Pr21 (see block diagrams). Speed control uses Pr7 or Pr6 as a reference depending on the value of b40.2. Before changing Pr31, b40.2 must be set to 0 to prevent undesired motor movement; it is now possible to set Pr31 to the value of the chosen operating mode and load default parameters by means of parameter b99.11. The operating mode will be enabled by setting b40.2 to 1.

3.6.1 Torque control

This operating mode (1) does not perform “classic” torque control because the speed loop remains active to monitor limit speed; the torque reference is the main reference Pr7. To set torque control first program the speed loop to create a stable system. Now set Pr2=1000 (10 V = 100.0 % torque) b40.0=0 & b40.12=0; b40.2=1 to program the reserved reference, Pr31=1 to enable the operating mode and Pr50 for maximum speed.

PARAMETERS FOR OPERATING MODE 1

Pr50 **Maximum speed.** Unit=rpm, default=3000, range=0..9000. This parameter makes it possible to limit maximum absolute motor speed during torque control operation.

3.6.2 Acceleration control

Instead of performing closed loop acceleration control, this mode (2) uses main reference Pr7 for dynamic modulation of the ramps. To program analogue acceleration control the first requirement is a stable speed loop. When this is present set Pr2=ACC / 3.2 where ACC is acceleration in rad/s² required with a 10V reference signal, b40.0 = 0, b40.12 = 0, b40.2 = 1 and Pr31 = 2. Maximum speed must be programmed in Pr50.

PARAMETERS FOR OPERATING MODE 2

Pr50 **Maximum speed.** Unit=rpm, default=3000, range=0..9000. This parameter makes it possible to limit maximum absolute motor speed during operation with acceleration reference.

Pr55 **Acceleration/deceleration ramp,** read-only parameter. Unit=s/krpm, range=2..30000, resolution=1 thousandth of a second.

Pr60:61 Reserved.

Pr62:63 Reserved.

Pr66:67 Reserved.

3.6.3 Maintenance and commissioning

This operating mode is designed to assist technical personnel during commissioning.

Mode 8 provides various tests to check drive wiring. It's also possible to move the shaft manually by means of Pr50, b70.1 and b70.2 or using the internal profile generator, which simplifies speed control loop set-up and ensures that there is no overrun on the programmed movement. Programming parameters for generating internal profiles are: speed, motor revolutions, starting position and interval, in seconds, between forward and reverse movement.

To perform the wiring test the motor must be disconnected from all loads, including inertia loads; disable the drive via software (b40.9=0), Pr30 must be zero, enable the drive via hardware and set b70.3=1. The drive will now execute the test routine. When terminated (b70.3=0), the error code in Pr56 can be displayed after setting Pr57=0.

Error codes:

| | |
|----|--|
| 0 | no error |
| 1 | b40.9=1 or drive disabled via hardware |
| 2 | motor phase sequence and resolver direction incompatible |
| 3 | number of motor poles and Pr29 incompatible |
| 4 | resolver phase error |
| 5 | Pr30 value not zero |
| 99 | procedure aborted |

By setting the various values in Pr57 you can get other useful information for installation and maintenance (see table in block diagrams).

PARAMETERS FOR OPERATING MODE 8

- Pr50 Manual speed.** Unit=rpm, default=100. This speed value is used for manual movements executed using b70.1 , b70.2 with b70.0=0 and b40.2=1.
- Pr51 Profile execution speed.** Unit=rpm, default=1000. This is the speed at which the trapezoidal profile is executed.
- Pr52 Distance.** Unit=revolutions, default=30. This is the number of revolutions of the motor shaft that must be performed during generation of the profile.
- Pr53 Starting point.** Default=1. If set to 1, at start profile (b70.0) the motor will start rotating and execute Pr52 revolutions with positive speed. If set to 2 the motor will start rotating and execute Pr52 / 2 revolutions with positive speed. If you set 3 the motor will start and execute Pr52 revolutions at negative speed.
- Pr54 Pause.** Unit= tenths of a second, default=1. During execution of the profile the drive stops between positive speed movement and negative speed movement for an interval of Pr54 at zero rpm.
- Pr55 Deviation factor.** During execution of the profile, assuming the same value of Pr16 the optimal value of Pr17 can be achieved by minimising the value of Pr55.
- Pr56 Value.** Returns information requested with Pr57.
- Pr57 Information request.** This parameter serves to query the drive. A table of queries is shown in the block diagram of operating mode 8.
- Pr58** Reserved.
- Pr59** Reserved.
- Pr60:61** Reserved.
- Pr62:63** Reserved.
- Pr64:65** Reserved.

Pr66:67 Reserved.

Pr68:69 Reserved.

b70.0 Start profile. Set 1 to execute the programmed profile. Remember to set b40.2=1 to effectively switch the speed reference to the control loop.

b70.1 Manual forward speed. If at 1 with b70.0=0 and b40.2=1, the shaft will rotate at the speed programmed in Pr50.

b70.2 Manual reverse speed. If at 1 with b70.0=0 and b40.2=1, the shaft will rotate at the speed programmed in Pr50 but in the opposite direction.

b70.3 Wiring test. When you set this command the drive performs a test procedure and returns the result as an error code that can be viewed using parameters Pr56 and Pr57. Before entering this command, make sure the motor is disconnected from all loads, even pure inertia loads. Also ensure that b40.9=0.

b70.4 Reserved.

b70.5 Vibration test. If none of the above functions is active, you can set this bit to one to evaluate the vibration of the motor shaft, incrementing parameter Pr64 in absolute terms by a value proportional to the vibration detected. The user is responsible for evaluating Pr64 and bringing it to zero in relation to the appropriate time interval.

b70.6 Reserved.

b70.7 Reserved.

b70.8 Reserved.

3.6.4 Positioner

Operating mode 9 executes a simple trapezoidal profile. For this profile the user must define acceleration with Pr51, steady time rpm with Pr52 and displacement using the pair of long format parameters Pr64 and Pr65. At each profile execution command, b70.8, the motor executes Pr64:65 steps (one motor revolution is equivalent to 4096 steps). The parameters of a trapezoidal profile cannot be changed during execution (b70.7=1), except Pr64:65. In the block diagram note the four different reset types, the availability of servo-error indication and the possibility of using space control with or without feed forward. The incremental position must be always positive and movement direction must be selected with parameter b70.1. Displacement can be defined using the drive frequency input. Additional features are available using the internal PLC.

Note that the profile execution command is not generated on a constant time base (profile calculation may require more than 2 milliseconds).

PARAMETERS FOR OPERATING MODE 9

Pr50 Pulse input multiplication factor K Default=1. If b70.9=1 frequency/direction input pulses are multiplied by Pr50 and the result is added to Pr64:65. The frequency input direction signal must be forced to a fixed level (logical 0). Refer to the chapter *Frequency input connection* for the connection diagrams.

Pr51 Acceleration time. Unit=s/krpm, range=0.002..30.000, resolution=0.001 sec, default=0.002 S. Acceleration ramp for positioning profile.

Pr52 Rpm at speed. Unit=rpm, default=1000. Steady state speed used during generation of the positioning profile.

Pr53 Reserved.

Pr54 Reserved.

- Pr55** Reserved.
- Pr56** **Servo-error window.** Unit=steps, default=100. If the position error as an absolute value exceeds the value set in Pr56, b70.5 is set to 1. If b70.5 is utilised it must be reset by the user following servo errors. This can be achieved, for example, by the PLC program.
- Pr57** **Position controller proportional gain.** Default=100, range 0..32000.
- Pr58** Reserved.
- Pr59** Reserved.
- Pr60:61** **Position controller reference.** Unit=steps.
- Pr62:63** **Motor position.** Unit=steps, 4096 steps per revolution.
- Pr64:65** **Incremental position.** Unit=steps. On receipt of the profile request, b70.8, the motor will execute Pr64:65 steps in the direction set in b70.4.
- Pr66:67** Reserved. Cannot be used during profile generation.
- Pr68:69** Reserved. Cannot be used during profile generation.
- b70.2** **Reset incremental position.** Resets Pr64:65. This command is useful when the incremental value is programmed on the frequency input.
- b70.4** **Forward/Reverse.** When the start profile command is transmitted (b70.8) if b70.4=0 the motor will execute Pr64:65 steps in the positive speed direction. If b70.4=1 it will execute the same number of steps in the negative speed direction.
- b70.5** **Servo error.** b70.5 is set to 1 if the absolute value of the position error is greater than the value set in Pr56. If utilised, b70.5 must be reset by the user, e.g. using the PLC program, following servo-errors.
- b70.6** **Feed-forward enable.** Default=0. If set to 1 feed-forward is enabled on the position controller.
- b70.7** **Profile in execution.** B70.7=1 indicates that the drive is executing a positioning profile.
- b70.8** **Start profile.** To start positioning.
- b70.9** **Enable frequency input.** Default=0. If set to 1, Pr64:65 can be set on the frequency input.
- b70.10** **Reset type 1.** Resets motor and reference position. This command is only accepted when no profile is in execution.
- b70.11** **Reset type 2** Command to set motor and reference position to equal the absolute position of the shaft. Accepted only when no profile is in execution.
- b70.12** **Reset type 3.** Command to set the reference equal to the motor position. Accepted only when no profile is in execution.
- b70.13** Reserved.
- b70.14** Reserved.
- b70.15** Reserved.

3.6.5 Digital locking

Operating mode 10 is a tracking function referred to a frequency input signal (connector X6) set as an encoder signal with b42.5=1; the encoder signal is counted on all A and B signal switching fronts. The motor position counter increases by 4096 steps each revolution. The ratio between master and slave can be entered using parameters Pr51 and Pr53. You can also select the ramp to utilise during catch or release cycles (Pr52), add slip speed (Pr58) and limit speed demands of the proportional part of the loop (Pr50). Further information available: master and slave locked and servo-error. Using Pr52, the main ramps and the internal PLC makes it possible to program various

different catch and release modes with or without phase recuperation. Refer to *Frequency input connection* chapter for connection diagrams.

PARAMETERS FOR OPERATING MODE 10

- Pr50 Maximum speed.** Unit=rpm, default=200, range =0..9000. This parameter makes it possible to limit maximum speed of the motor; it can be used to limit speed during a catch on fly cycle or during sudden speed changes (see Pr58).
- Pr51 Reference multiplication factor.** Default=1, range =-32000..+32000. This parameter, together with Pr53, makes it possible to set the required ratio for the input reference frequency.
- Pr52 Acceleration/deceleration ramp.** Unit=s/krpm, default=500, range=0..30000, resolution=1 thousandth of a second. The acceleration/deceleration demanded of the motor can be restricted so that a speed decrease or increase of 1000 rpm takes Pr52 thousandths of a second; this function is useful during catch on fly cycles.
- Pr53 Reference division factor.** Default=1, range=-32000..+32000. This parameter together with Pr51 makes it possible to set the required ratio for the input reference frequency.
- Pr54** Reserved.
- Pr55 Required speed.** Unit=rpm Read-only parameter. Shows the input reference frequency converted into rpm
- Pr56 Servo-error window.** Unit=steps, default=100. If the absolute value of the position error exceeds the value set in Pr56, b70.5 is set to 1. If utilised, b70.5 must be reset by the user, e.g. by the PLC program, following servo-errors.
- Pr57 Position controller proportional gain.** Default=100, range 0..32000.
- Pr58 Slip speed.**
- Pr59** Reserved.
- Pr60:61 Position controller reference.** Unit=steps.
- Pr62:63 Motor position.** Unit=steps, 4096 steps per revolution.
- Pr64:65** Reserved.
- Pr66:67** Reserved.
- Pr68:69** Reserved.
- b70.2 Digital locking engaged.** During locking with ramp (Pr52) other than zero, this bit indicates the termination of the transitional phase.
- b70.3 Enable position.** Default=0. During unlocking b70.3=1 enable position with Pr61:60.
- b70.5 Servo-error.** b70.5 is set to 1 if the absolute value of the position error exceeds the value set in. If utilised, b70.5 must be reset by the user, e.g. by the PLC program, following servo-errors.
- b70.6 Feed-forward.** Default=1. If set to 1 feed-forward is enabled on the position controller.
- b70.8 Axis lock/release.** With this bit you can lock (=1) or release (=0) the axis from the input encoder reference.
- b70.9** Reserved.
- b70.10 Reset type 1.** Resets motor and reference position. Implemented only with b70.8=0.
- b70.15** Reserved.

3.6.6 Stepper motor emulation

This mode emulates the operation of a stepper motor: each pulse received on the frequency input (terminal board X6 channel A=frequency, channel B=direction) is multiplied by Pr51 and the result is added to the reference position. The frequency input must be programmed as a direction/sign signal by setting b42.5=0. Just as in all other operating modes it is possible to enable feed forward, limit the action of the proportional part, obtain servo-error indication and select the most suitable type of reset. Note that the frequency count occurs on the negative front of the signal and changes of the direction signal must be made at least 1 μ S before the negative frequency front. Unlike stepper motors, in this case there is no risk of step loss. Refer to *Frequency input connection* chapter for the connection diagrams.

PARAMETERS FOR OPERATING MODE 11

- Pr50** **Maximum speed.** Unit=rpm, default=3000, range=0..9000. This parameter makes it possible to limit maximum motor speed.
- Pr51** **Reference multiplication factor.** Default=1, range=-0..+4096. This parameter allows you to set the required multiplication ratio for input reference frequency.
- Pr54** Reserved.
- Pr56** **Servo-error window.** Unit=steps, default=100. If the absolute position error is greater than the value in Pr56, b70.5 is set to 1. If utilised, b70.5 must be reset by the user, e.g. by the PLC program, following servo-errors.
- Pr57** **Position control loop proportional gain.** Default=100, range 0..32000.
- Pr60:61** **Position control loop reference.** Unit=steps.
- Pr62:63** **Motor position.** Unit=steps, 4096 steps per revolution.
- Pr64:65** Reserved.
- b70.5** **Servo-error.** b70.5 is set to 1 if the absolute position error is greater than the value in Pr56. If utilised, b70.5 must be reset by the user, e.g. by the PLC program, following servo-errors.
- b70.6** **Feed-forward enable.** Default=0. If set to 1 feed-forward is enabled on the position controller.
- b70.8** **Axis lock/release.** With this bit you can lock (=1) or release (=0) the axis from the input encoder reference.
- b70.9** Reserved.
- b70.10** **Reset type 1.** This command resets motor and reference position.
- b70.11** **Reset type 2.** Sets motor and reference position equal to the absolute shaft position.
- b70.12** **Reset type 3.** Sets the reference equal to the motor position.

3.6.7 Spindle orientation

When this mode (12) is selected it becomes operational when b40.2=1. The motor reaches the speed in Pr50 on the ramps in Pr52. It now spins at constant speed until it reaches the position set in Pr54; at this point the position loop is closed.

PARAMETERS FOR OPERATING MODE 12

- Pr50** **Maximum speed during spindle orientation.** Unit=rpm, default=200, range=0..500.
This parameter makes it possible to limit maximum motor speed during spindle orientation.
- Pr51** Reserved.
- Pr52** **Deceleration ramp.** Unit=s/krpm, default=500, range=2..30000, resolution=1 thousandth of a second. When the spindle orientation command is set (b40.2=1) deceleration required of the motor can be limited by this parameter so that a change of 1000 rpm takes Pr52 thousandths of a second.
- Pr53** Reserved.
- Pr54** **Motor shaft position for spindle orientation.** Unit=steps, default=0, range=0..4095.
One revolution of the motor shaft corresponds to 4096 steps.
- Pr56** **Servo-error window.** Unit=steps, default=100. If the absolute position error is greater than the value set in Pr56, b70.5 is set to 1.
- Pr57** **Position control loop proportional gain.** Default=100, range = 0..32000.
- Pr58** Reserved.
- Pr59** Reserved.
- b70.5** **Servo-error.** b70.5 is set to 1 if the absolute position error is greater than the value in Pr56, otherwise it is set to zero.

3.7 Block diagrams

The main block diagram provides a graphic description of how to use the drive. Each rectangular block represents one or more read/write parameters, each rhomboid shape represents read-only parameters. In the diagram there are other functional blocks such as: greater than..., equal to, the smallest among..., logical and/or; we have used standard symbols for all these blocks. Binary parameters are shown as switches and the position depicted is the default value.

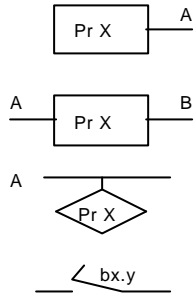

- Read/write parameter PrX
A = value of PrX
- Read/write parameter PrX
B = value according to values of A and PrX
- Read-only parameter
PrX is value of A (can also be binary)
- Read/write bit parameter
switch position shows bx.y=0

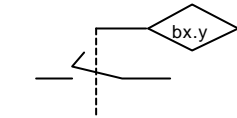

- Value of bit parameter bx.y sets the switch

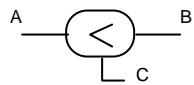

- If A is smaller than B, C = 1 (true); otherwise C = 0 (false)

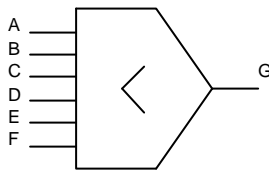

- The value of G is the lower value among A B C D E and F

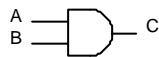

- C = 1 only when A = 1 and B = 1; otherwise C = 0



- If A or B are 1, C = 1
otherwise C = 0

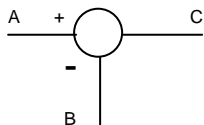

- C = A - B



- values from hardware



- values to hardware

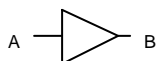

- Value of A is converted to B. E.g., if the triangle symbol contains A/D, the analogue value of A is converted into the digital value B

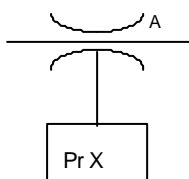

- Maximum value of A is PrX

HIGH PERFORMANCE DRIVE MAIN BLOCK DIAGRAM

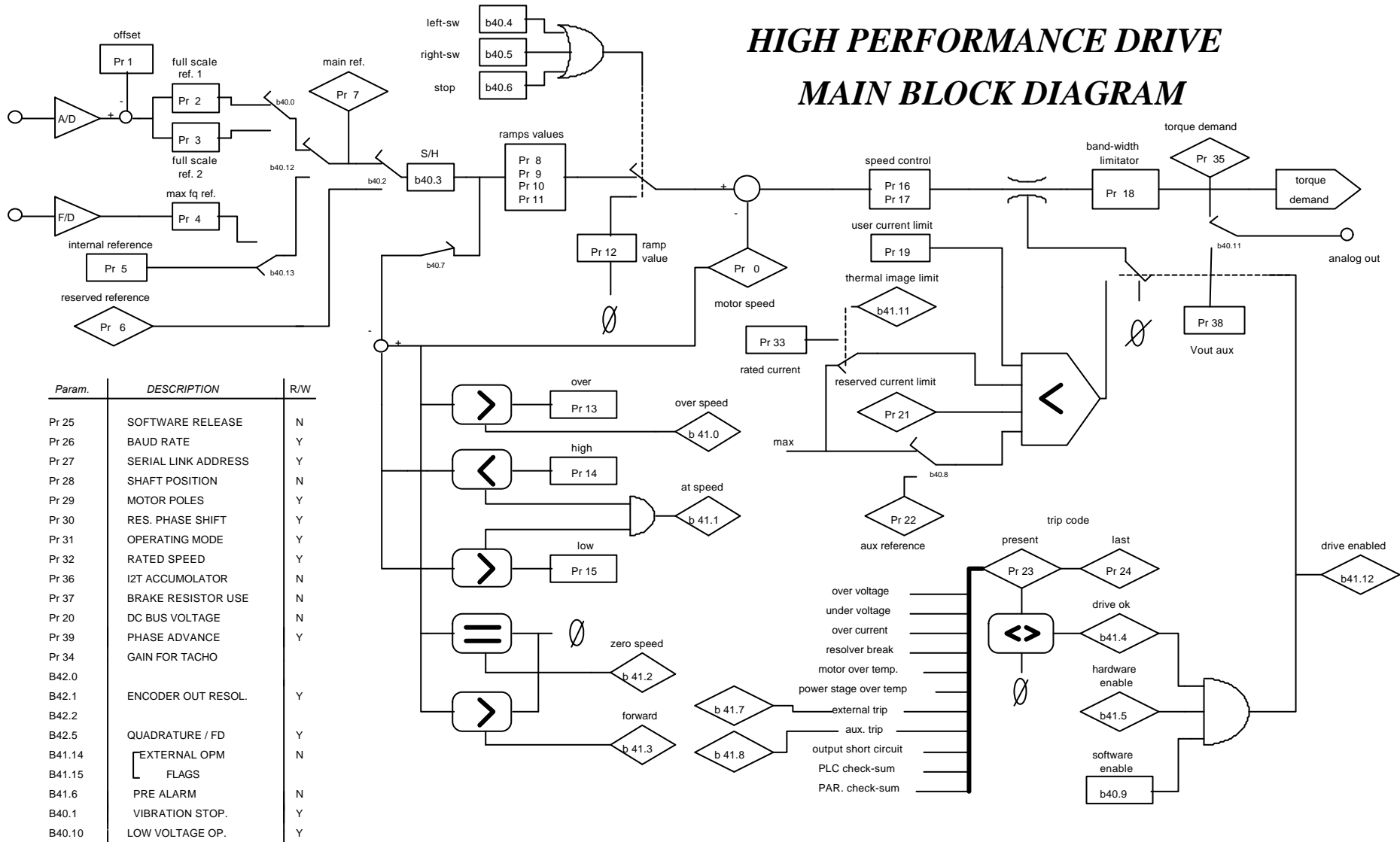

| Param. | DESCRIPTION | R/W |
|--------|---------------------|-----|
| Pr 25 | SOFTWARE RELEASE | N |
| Pr 26 | BAUD RATE | Y |
| Pr 27 | SERIAL LINK ADDRESS | Y |
| Pr 28 | SHAFT POSITION | N |
| Pr 29 | MOTOR POLES | Y |
| Pr 30 | RES. PHASE SHIFT | Y |
| Pr 31 | OPERATING MODE | Y |
| Pr 32 | RATED SPEED | Y |
| Pr 36 | I2T ACCUMULATOR | N |
| Pr 37 | BRAKE RESISTOR USE | N |
| Pr 20 | DC BUS VOLTAGE | N |
| Pr 39 | PHASE ADVANCE | Y |
| Pr 34 | GAIN FOR TACHO | Y |
| B42.0 | | |
| B42.1 | ENCODER OUT RESOL. | Y |
| B42.2 | | |
| B42.5 | QUADRATURE / FD | Y |
| B41.14 | EXTERNAL OPM | N |
| B41.15 | FLAGS | |
| B41.6 | PRE ALARM | N |
| B40.1 | VIBRATION STOP. | Y |
| B40.10 | LOW VOLTAGE OP. | Y |

REFERENCE SELECTION

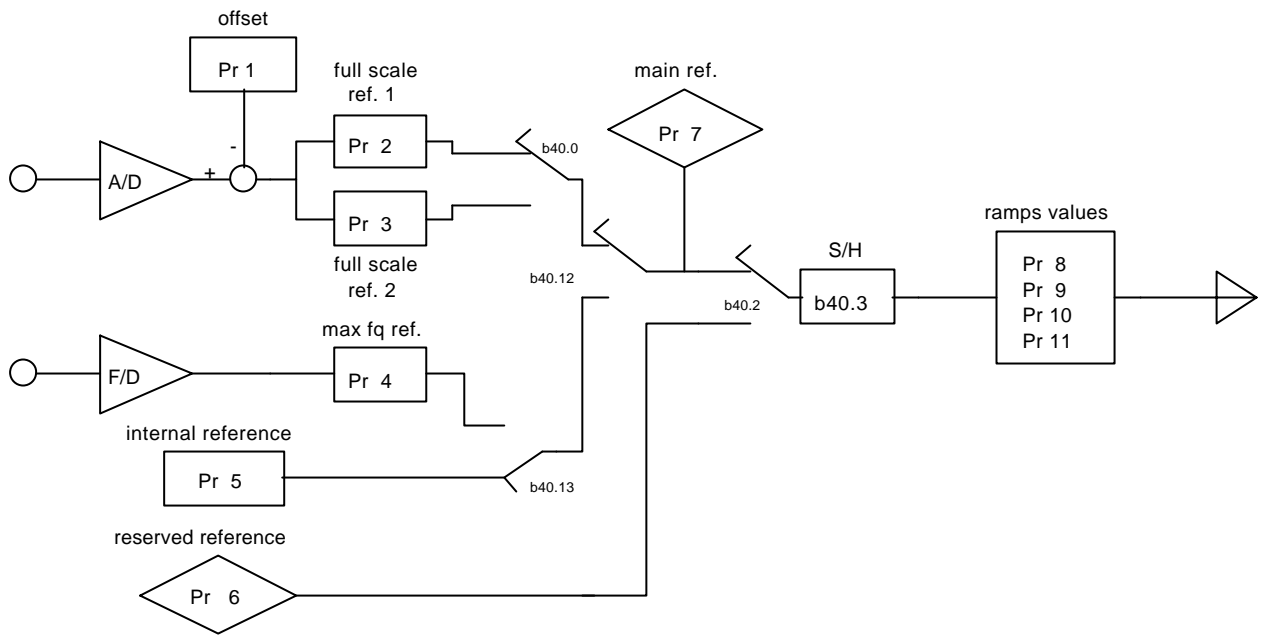

1

**TORQUE CONTROL
OPERATING MODE**

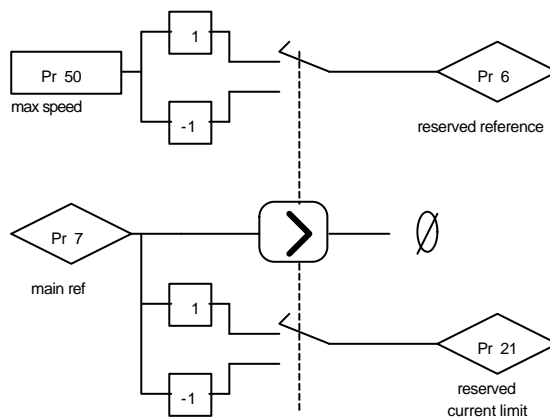

2 ACCELERATION CONTROL OPERATING MODE

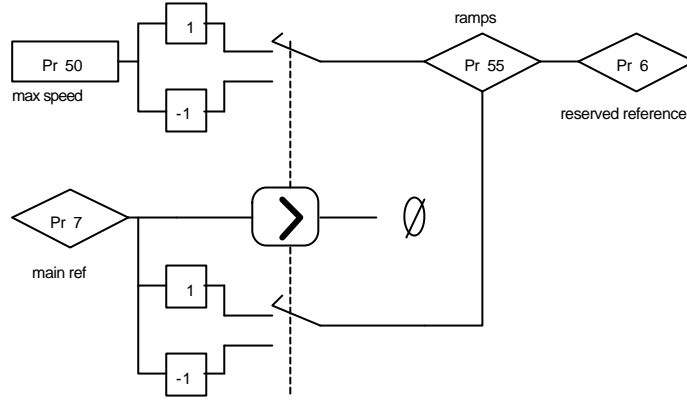

8 MAINTENANCE & COMMISSIONING OPERATING MODE

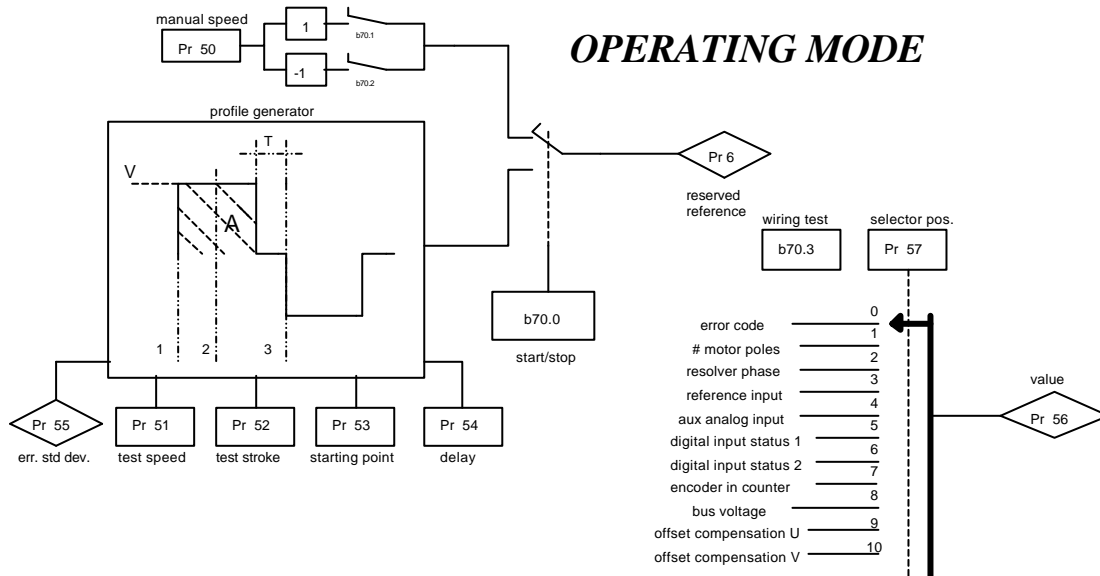

9

**TRAPEZOIDAL POSITIONER
OPERATING MODE**

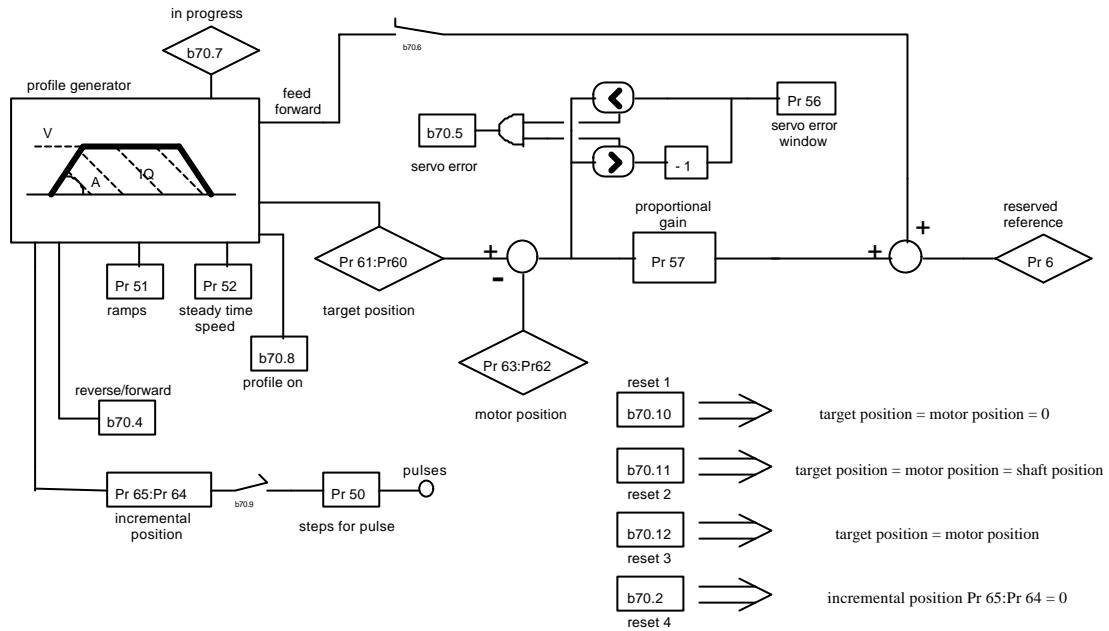

10

**DIGITAL LOCK
OPERATING MODE**

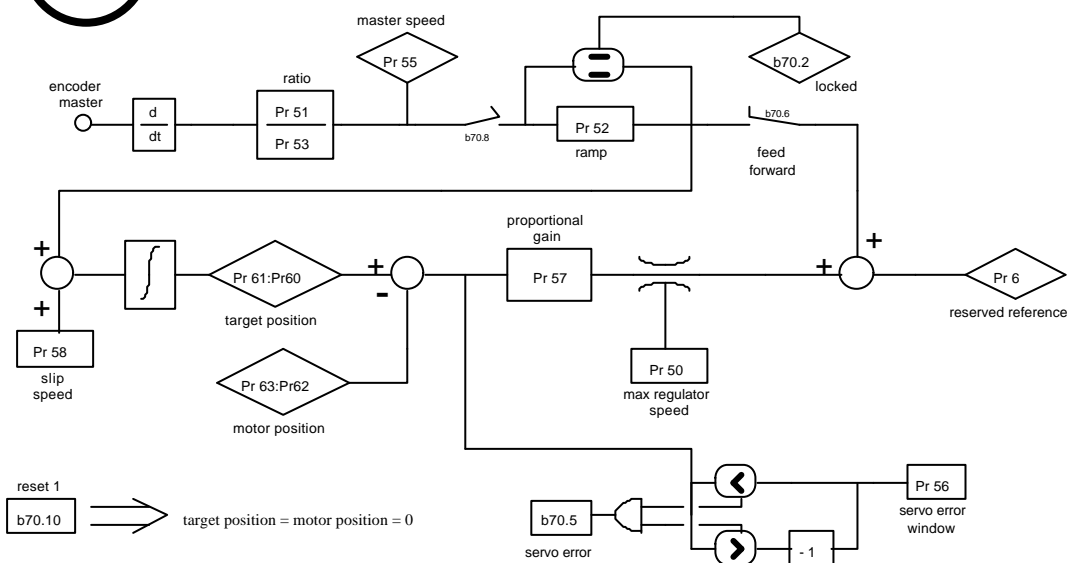

11

STEPPER LIKE OPERATING MODE

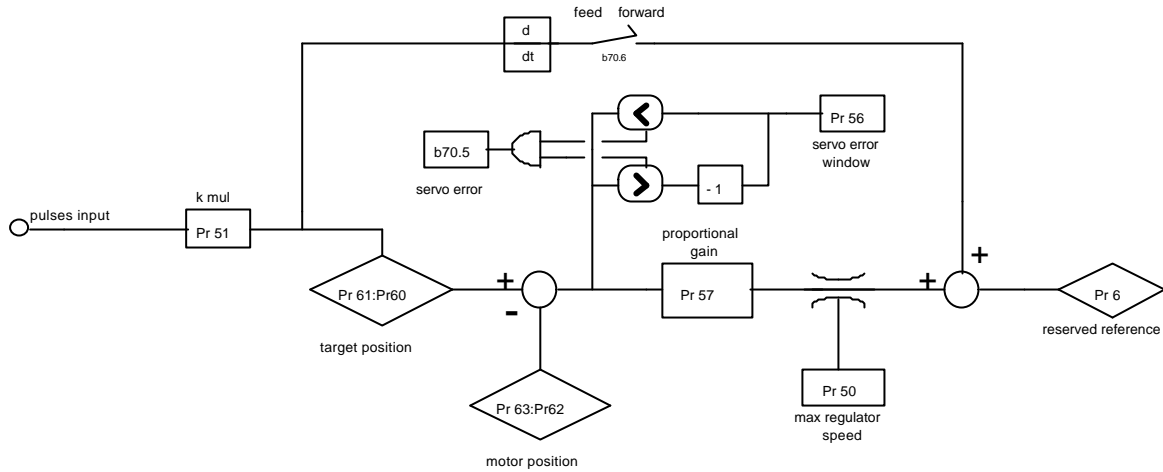

- reset 1
b70.10 ⇒ target position = motor position = 0
- reset 2
b70.11 ⇒ target position = motor position = shaft position
- reset 3
b70.12 ⇒ target position = motor position

SPINDLE ORIENTATION OPERATING MODE

12

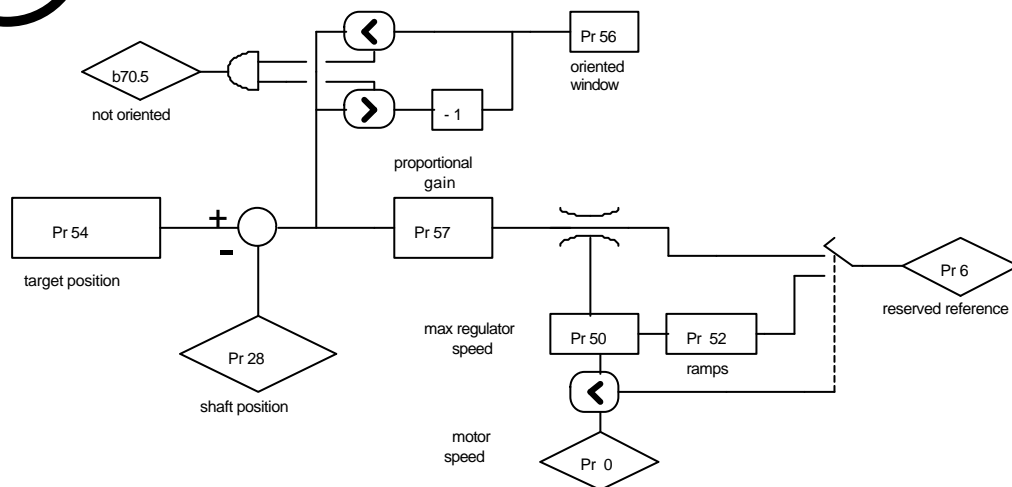

3.8 Digital input and output programming

3.8.1 Pico-PLC

The internal pico-PLC makes it possible to connect peripheral systems (inputs/outputs) to the parametric system of the HPD drive. The PLC can be used to copy a digital input into a bit parameter, copy a bit parameter into a digital output and perform mathematical and boolean calculations. The PLC program must be entered as a list of instructions from the keypad; alternatively the PLC can be programmed with the ladder diagram system using a PC on the serial line with an interface such as Pbrush. Default parameterisation (b99.12) provides a PLC program (see appendix G) designed to fill the requirements of the broadest possible range of applications, therefore it is not necessary to reprogram the PLC in the majority of cases.

Main features of the PLC:



| | |
|--------------------------------|---------------------|
| Program steps | 64 |
| scan time | 6.144 ms |
| timers | 2 |
| instructions | 15 |
| stack depth | 1 |
| mathematic operations | 16 / 32 bits |
| fast inputs (fast copy) | 3 - (512 ms) |

PLC PARAMETERS

- Pr71** Constant value = -1. Double word.
- Pr72** Constant value = 0. Double word.
- Pr73** Constant value = 1. Double word.
- Pr74** Constant value = 2. Double word.
- Pr75** Constant value = 10. Double word.
- Pr76** Constant value = 100. Double word.
- Pr77** Constant value = 1000. Double word.
- Pr78** Constant value = 1024. Double word.
- Pr79** Constant value = 4096. Double word.
- Pr80** Free parameter. Parameter with save facility at user's disposal (word).
- Pr81** Free parameter. Parameter with save facility at user's disposal (word).
- Pr82** Free parameter. Parameter with save facility at user's disposal (word).
- Pr83** Free parameter. Parameter with save facility at user's disposal (word).
- Pr84** Free parameter. Parameter with save facility at user's disposal (word).
- Pr85** Free parameter. Parameter with save facility at user's disposal (word).
- Pr86** Free parameter. Parameter with save facility at user's disposal (word).
- Pr87** Free parameter. Parameter with save facility at user's disposal (word).
- Pr88** Free parameter. Parameter with save facility at user's disposal (word).
- Pr89** Free parameter. Parameter with save facility at user's disposal (word).
- b90.X** Digital input X status. If X is greater than 7, parameter with save facility at user's disposal (b90.0 = drive enable).
- b91.Y** Digital input Y status. If Y is greater than 7, parameter with save facility at user's disposal. Parameter Pb91 is not saved at power up and is definitely at zero.

- Pr92 First PLC timer.** Every 6.144 ms if Pr92 is not at 0 the timer is decreased, if set to zero b99.0 is set at 1.
- Pr93 Second PLC timer.** Every 6.144 ms if Pr93 is not at 0 the timer is decreased, if set to zero b99.1 is set to 1.
- b94.0 Forces a double word formatted operation.** When the drive is powered up this parameter is on zero. If it is on one, the first mathematical operation of the pico-PLC is executed setting the three operands as double word type; after the operation is executed b94.0 is automatically set to zero.
If Pr60..Pr68 are utilised, double word formatting is automatic (see text).
- b94.5 Disables the first fast input** (b94.5=0). Set to zero at power-up.
- b94.6 Disables the second fast input** (b94.6=0). Set to zero at power-up.
- b94.7 Disables the third fast input** (b94.7=0). Set to zero at power-up.
- b99.0 First timer status.** At 1 if Pr92 = 0
- b99.1 Second timer status.** At 1 if Pr93 = 0
- b99.2** At 1 if the result of the last PLC operation is negative.
- b99.3** At 1 if the result of the last PLC operation is zero.
- b99.13 PLC status.** Default=1. If set to 1 the PLC program is executed, if on zero the program is not executed and modification of PLC instructions is enabled.

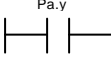
PLC INSTRUCTIONS

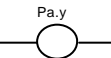
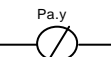
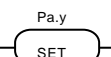
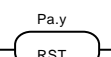
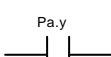
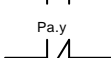
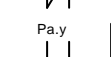
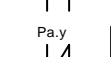
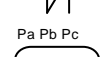
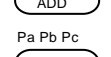
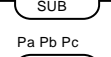
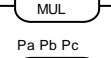
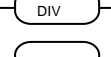
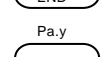
| | | | |
|---|-------------|-------------------|--|
|  | LD | Pa,y | load bit y of parameter Pa in the stack |
|  | LDN | Pa,y | load inverted bit y of parameter Pa in the stack |
|  | OUT | Pa,y | set bit y of parameter Pa to the value loaded in the stack |
|  | OUTN | Pa,y | set bit y of parameter Pa to the stack value and invert it |
|  | SET | Pa,y | if stack is at 1, set bit y of parameter Pa to 1 |
|  | RES | Pa,y | if stack is at 1, set bit y of parameter Pa to zero |
|  | AND | Pa,y | the bit loaded into the stack assumes the result of the logical AND operation between itself and bit y of parameter Pa |
|  | ANDN | Pa,y | the stack bit assumes the result of the logical AND between itself and inverted bit y of parameter Pa |
|  | OR | Pa,y | the bit loaded into the stack assumes the result of the OR between itself and bit y of parameter Pa |
|  | ORN | Pa,y | the stack bit assumes the result of the OR between itself and inverted bit y of parameter Pa |
|  | ADD | Pa, Pb, Pc | if stack bit is at 1, parameter sum operation is executed, therefore: $Pc = Pa + Pb$ |
|  | SUB | Pa, Pb, Pc | if stack bit is at 1, subtraction operation is executed on parameters, therefore: $Pc = Pa - Pb$ |
|  | MUL | Pa, Pb, Pc | if stack bit is at 1, multiplication operation is executed on parameters, therefore: $Pc = Pa \cdot Pb$ |
|  | DIV | Pa, Pb, Pc | if stack bit is at 1, division operation is executed on the parameters, therefore: $Pc = Pa / Pb$ |
|  | END | | program end |
|  | FIN | y, 0/1 | fast scanning input |

OPERATIONAL DESCRIPTION

The pico-PLC program is scanned every 6.144 msec; at each sampling first the inputs are read, then the two timers are updated (Pr92 Pr93 b99.0 and b99.1), the user program is scanned, and finally the outputs are updated. Therefore, reading of the inputs and output updates can deviate temporally by up to 6.144 ms with respect to the physical event.

All pico-PLC instructions with the exception of mathematical instructions, operate on single bits; moreover, available stack depth is a single bit.

Instruction LD (LDN) loads the bit defined as operand into the stack, while all other logical instructions operate on the stack. Mathematical operations are executed only if the stack bit is at 1.

The following logic operations truth tables are provided for the user's convenience:

| logical AND operations | | |
|------------------------|-------|--------|
| bit A | bit B | result |
| 0 | 0 | 0 |
| 0 | 1 | 0 |
| 1 | 0 | 0 |
| 1 | 1 | 1 |

| logical OR operations | | |
|-----------------------|-------|--------|
| bit A | bit B | result |
| 0 | 0 | 0 |
| 0 | 1 | 1 |
| 1 | 0 | 1 |
| 1 | 1 | 1 |

The relative inverted ANDN and ORN operations follow the same logic, except they use the inverted value of the specified bit.

There are 8 bits with save facility from b90.8 to b90.15 reserved for the PLC; a further 8 bits from b91.8 to b91.15 are available for the PLC; these are not stored and are always at zero at drive power-up.

Also 10 word parameters are reserved, specifically from Pr80 to Pr89 with save facility and option for use as 5 double word parameters. For mathematical operations the pico-PLC has 9 constants available, from Pr71 to Pr79 selected from those that are most frequently utilised in standard applications.

When using mathematical instructions (ADD, SUB, MUL, DIV) note that operators are assumed as words with their relative signs. If a double word operation is necessary, parameter b94.0 must be set to 1 before the operation; after the operation the PLC will automatically set the bit to zero. Parameters Pr60...Pr69 are considered as double words so an operation like [ADD 71 72 64] will write the result -1 in the double word Pr64:65 without having to set b94.0=1 before the operation. If Pr80=-1 and Pr81=0, the operation [ADD 80 72 64] will have the result Pr64:65=-1, while the same operation performed with b94.0=1 will assume Pr81 as the high part of the double word Pr80:81 so the result will be Pr64:65=65535. In the first case, therefore, operands other than Pr60...Pr69 will be treated as words, while in the second case they will be treated as double words.

Note that in mathematical operations on double words, operands and results are defined as follows: the operand parameter defines the least significant part while the most significant part is represented by the word with the next serial address (see chapter *Serial addresses and parameter lengths*). Parameters from Pr50 to Pr69 and from Pr80 to Pr89 are successive.

At the completion of each mathematical operation b99.2 is set to 0 if the result is positive, and to 1 if the result is negative; likewise, b99.3=0 if the result is zero and b99.3=1 if it is different from zero. These settings remain valid until the next mathematical operation is performed (the operation is executed only if the stack bit is equal to one). A mathematical operation can be performed, setting the result in one of the constant parameters (Pr71...Pr79) in order to set bits b99.2 and b99.3.

In the case of the DIV operation, if it is executed on a double word the most significant part of the result contains the rest of the division, i.e. if you set b94.0=1 and perform [DIV 79 77 80] the result will be Pr80=4 and Pr81=96.

Note that parameters Pr23, Pr24, Pr25, Pr26, Pr27, Pr29, Pr31 and Pr34 are bytes like Pb42 and Pb94; therefore, these parameters cannot be used for mathematical operations; logical operations must be used to alter their values.

FIN instruction. Three instructions are provided for high speed input acquisition: in this case the scan is executed at 512 μ s (normal scanning is 6.144ms). If used, FIN instructions must be the first PLC instructions. The first FIN instruction copies digital input 1 into bit y of parameter Pb40 (second operand=0) or Pb70 (second operand =1). The second FIN instruction copies digital input 2 into bit y of parameter Pb40 (second operand=0) or Pb70 (second operand=1). The third FIN instruction copies digital input 3 into bit y of parameter Pb40 (second operand=0) or Pb70 (second operand=1). If the second operand is added to value 2, before the input is copied it will be inverted. If a FIN instruction is included at any other position in the program it will have no effect. FIN instructions can be enabled/disabled for each FIN: 1st FIN enabled if b94.5=0; 2nd FIN enabled if b94.6=0; 3rd FIN enabled if b94.7=0.

A FIN instruction in the PLC program after the first three instructions or after any other type of instruction will always be ignored.

There are two timers Pr92 and Pr93 at the disposal of the user. To use the first timer simply load the time in terms of number of samplings (6.144 ms) in parameter Pr92: for example Pr92=100 is equivalent to 614 milliseconds. Pr92 automatically decreases through time, bit b99.0 remains on zero until the timer interval has elapsed; when Pr92=0 then b99.0=1. The same functionality applies to the second timer regarding parameter Pr93 and bit b99.1. Ensure that Pr92 Pr93 b99.0 and b99.1 are refreshed only after the first pico-PLC program scan.

The maximum number of instructions is 64 including the END instruction. Note that mathematical operations occupy the space of two logical operations so when they are used the maximum number of instructions available is decreased accordingly.

The PLC program must always be terminated with an END instruction.

The pico-PLC program can be edited on a PC (see *Programming with Pcbrush*) or directly from the keypad. In this latter case, to facilitate procedures, when you need to delete an instruction, select it and then press [M] to display the type of instruction; now keep [M] pressed and simultaneously press [-]; when both keys are released the instruction will be deleted. On the contrary, in order to add an instruction after In06 for example, select the next instruction In07, press [M] to display the type of instruction; now keep [M] pressed and press [+] simultaneously; when both keys are released an FIN instruction will be inserted. In this latter procedure make sure that the instructions in the program are no more than the maximum number or you will lose the last one(s). The pico-PLC program can be edited or altered only when the PLC is in stop status (b99.13=0).

3.8.2 Examples and applications

The following examples illustrate possible functionalities obtained by suitable programming of the HPD pico-PLC. The suggested solutions offer the possibility of reducing the components required to build the machine or part of the machine while, in many cases, also cutting the overall cost of the application. Note that the pico-PLC scanning time is 6.144 msec and the maximum number of instructions is 64; moreover, the PLC is designed principally to manage the drive's digital inputs and outputs.

In addition to a concise description of the application, the examples show the settings required for HPD parameters and the pico-PLC program. The program is shown in ladder diagrams and instruction listings.

Example 1: two inputs for on/off functions

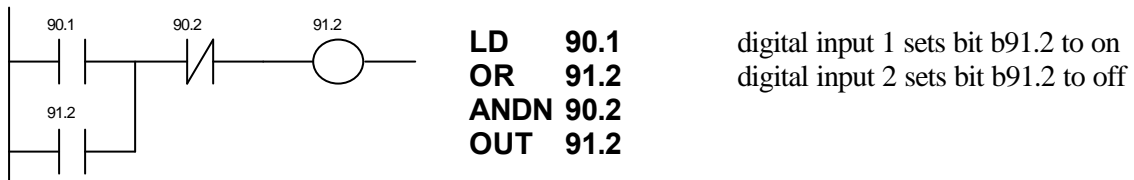

Example 2: changing a parameter value with the up/down keys

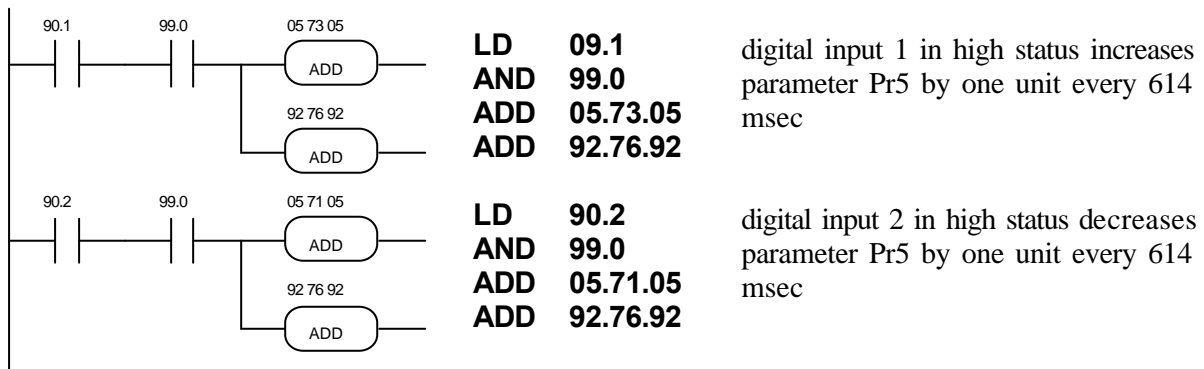

Example 3: command on positive front of a digital input

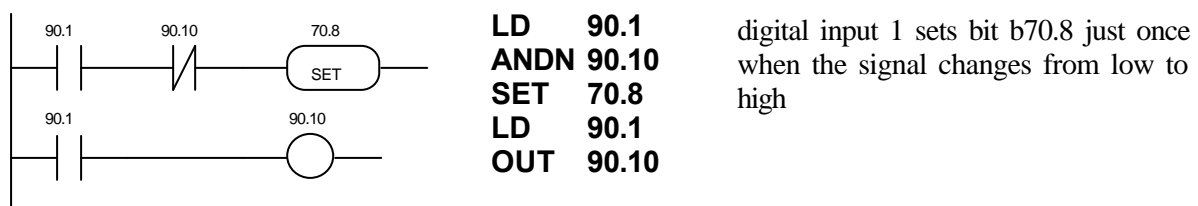

Example 4: filtered digital input at 60 msec

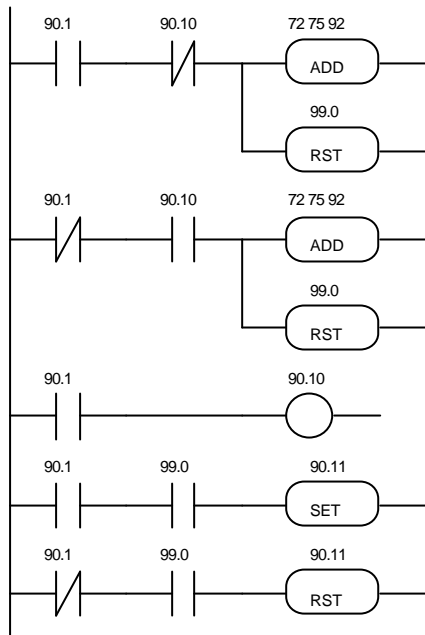

LD 90.1
ANDN 90.10
ADD 72,75,92
RST 99.0

if digital input 1 is low, load 60 msec on counter;
 if digital input 1 is high for 60 msec b99.0 will be set to 1 and b90.11=1

LDN 90.1
AND 90.10
ADD 72,75,92
RST 99.0

if digital input 1 is high, load 60 msec on counter
 if digital input 1 is low for 60 msec, b99.0=1 and b90.11=0

LD 90.1
OUT 90.10

LD 90.1
AND 99.0

SET 90.11

LDN 90.1
AND 99.0
RST 90.11

b90.11 is the status of filtered digital input 1

Example 5: correlation between parameter values

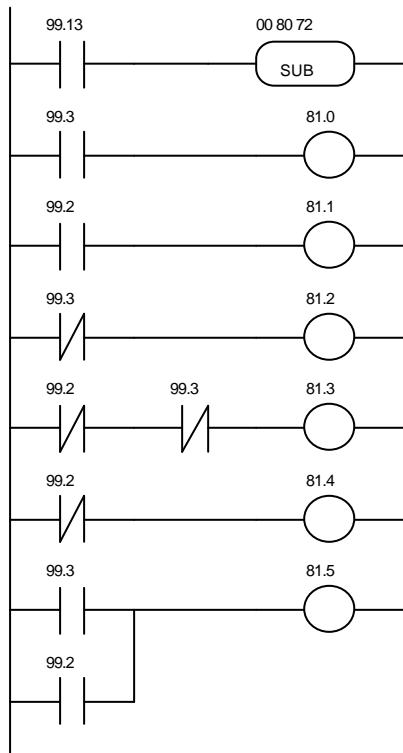

LD 99.13
SUB 0,80,72

calculate difference between Pr0 and Pr80 to set b99.2 and b99.3

LD 99.3
OUT 81.0

if Pr0=Pr80 then b81.0=1

LD 99.2
OUT 81.1

if Pr0<Pr80 then b81.1=1

LDN 99.3
OUT 81.2

if Pr0<>Pr80 then b81.2=1

LDN 99.2
ANDN 99.3
OUT 81.3

if Pr0>Pr80 then b81.3=1

LDN 99.2
OUT 81.4

if Pr0>=Pr80 then b81.4=1

LD 99.3
OR 99.2
OUT 81.5

if Pr0<=Pr80 then b81.5=1

Example 6: filter (600 msec) for reading the value of a parameter

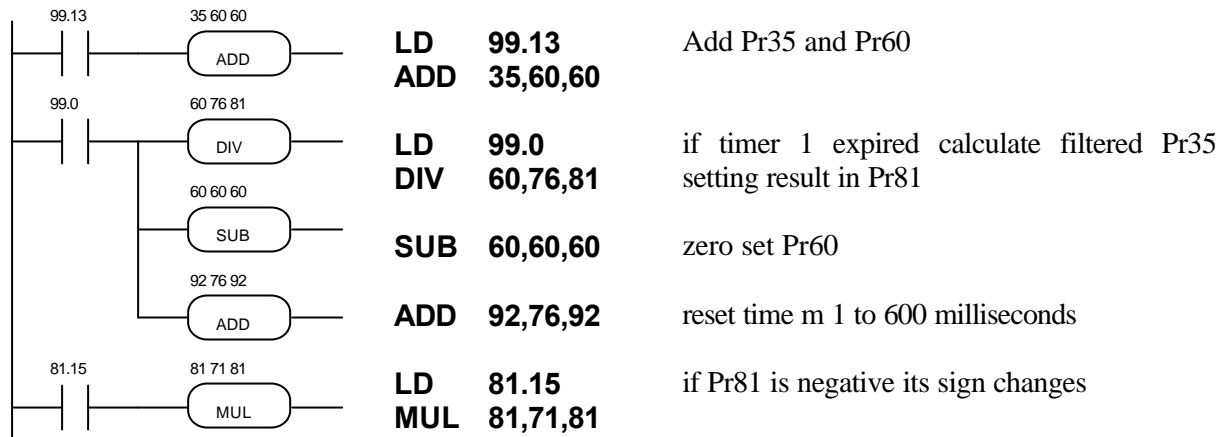

Example 7: homing

If you are using an operating mode with spatial control (9, 10 or 11) and you need to align the motor with a zero position defined by a proximity sensor when the system is powered up. You can use two digital inputs, one for the homing command and one to acquire the proximity sensor signal. The commands are pulse type and the homing command is executed once only.

After setting the default values set up the required operating mode (Pr31=xx, b99.11=1, b40.2=1, and any other settings required) and then set the homing speed for the zero proximity sensor in Pr5 and set b40.12=1 to enable Pr5 when b40.2 reaches zero.

Terminal 13 on X3 = pulse command - execute homing.

Terminal 14 on X3 = PNP axis zero proximity sensor.

Bit b91.10 is utilised to signal that the operation is terminated. Note that bits from b91.8 to b91.15 are at the disposal of the PLC and cannot be stored in the memory.

The program is as follows:

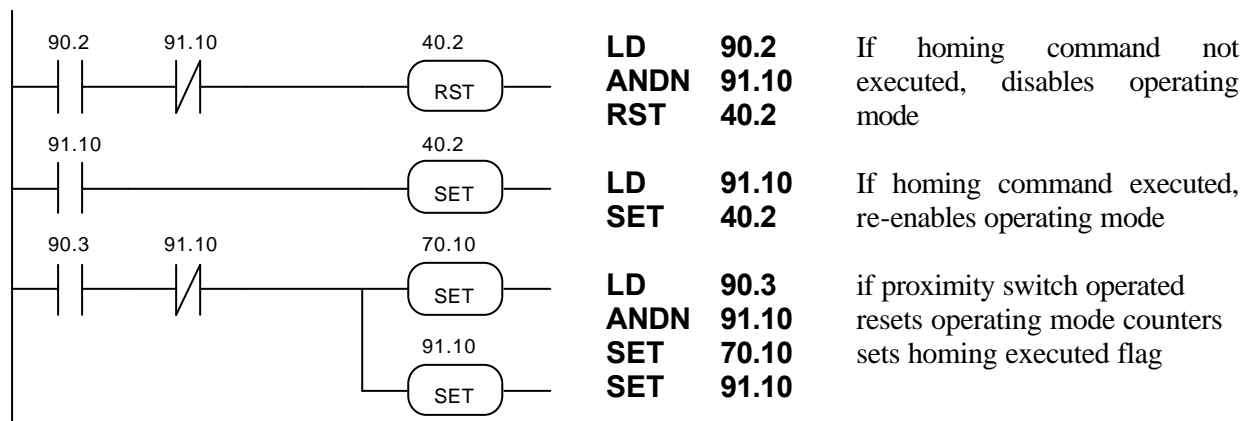

In certain cases a more precise axis zero reference is required; this is achieved using, in addition to the proximity sensor on the machine, also the motor position transducer. In this setup the proximity sensor signal is correlated with the first zero on the motor position transducer.

The following example provides this functionality using operating mode (9) (trapezoidal profile).

After setting default values, set up operating mode 9 (Pr31=9, b99.11=1, b40.2=0, b40.12=1, and any other settings required) and then enter the zero proximity sensor homing speed in Pr5.
 Terminal 13 on X3 = homing pulse command.
 Terminal 14 on X3 = PNP type axis zero proximity sensor.
 Terminal 11 on X2 = digital output. Switches to 1 when the homing phase is terminated.
 The following bits are utilised b91.8, b91.9, b91.11.

The program is as follows:

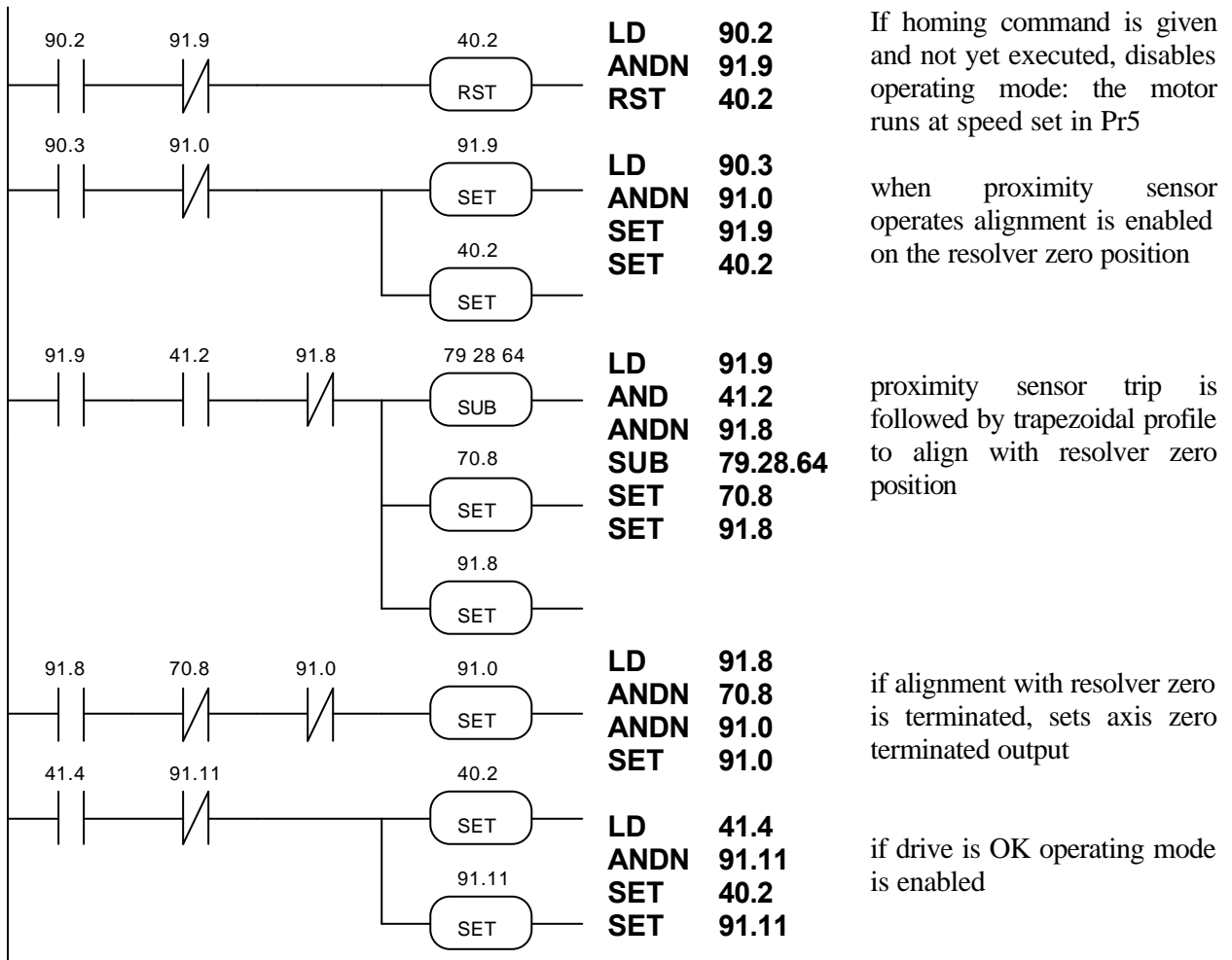

Example 8: execution of modulus in digital locking

(FILE: E001.HPD)

To obtain the following functionality: with reference to the figure assume you have a conveyor transporting product and a blade roller driven by the HPD drive. At start up on an external command the blade roller is aligned with a zero reference (proximity sensor). On receipt of the next pulse command, which is generated by a product detection sensor, the blade roller drive locks onto the conveyor master so that the product is always cut at precisely the same length; when the cut is terminated the blade roller reassumes the starting position awaiting the next cutting command.

In this case the program permits the homing procedure (see chapter 1) and then, on receipt of the command from the product sensor, it assumes digital locked mode and covers a space equal to the value of Pr87:86; when it reaches this distance the drive unlocks and ramps down to the standby position defined by parameter Pr89:88 = modulus. Note that one motor shaft revolution corresponds to 4096 steps so the modulus value to set is equal to the number of steps required by the motor shaft to execute a full revolution of the blade roller. The value of Pr87:86 must be less than the value of the modulus (=Pr89:88).

The master encoder mounted to the conveyor shaft provides the drive with a position reference during the digital locking phase.

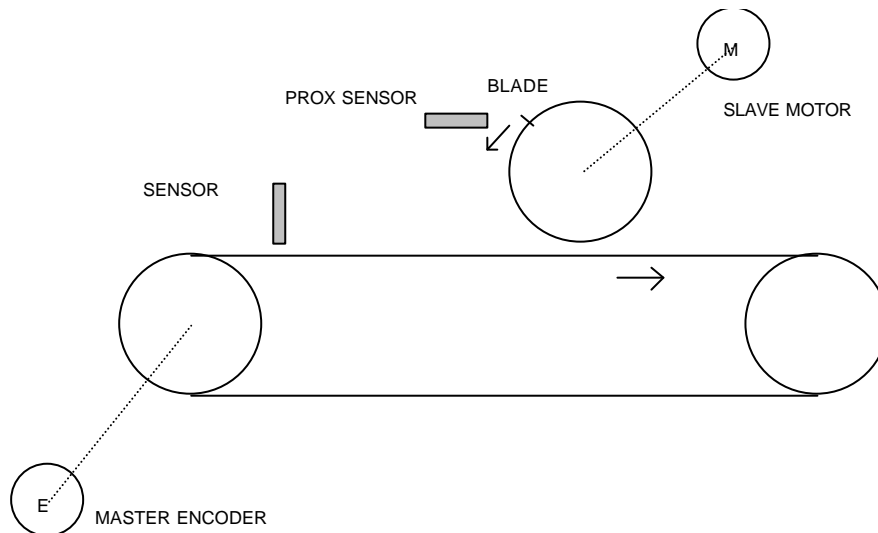

When you have set the default values set the following parameters: Pr5=10 (homing speed), Pr31=10, b99.11=1, b40.2=1, b40.12=1, Pr52=0, b70.3=1, Pr87:86=modulus - ramp, Pr89:88=modulus in which the ramp is expressed in steps, i.e. it is the space that the axis must cover during ramp down. Pay attention when programming Pr89:88 and Pr87:86 because these parameters are utilised as double word format by the PLC but they must be set up as two pairs of single whole words from the keypad. For example, if the modulus is 40960 steps, Pr89 must be set to 0 and Pr88 must be set to 24576.

Terminal 13 on X3 = homing pulse command

Terminal 14 on X3 = NPN type axis zero proximity sensor

Terminal 12 on X3 = pulse command - digital locking engage sensor.

Terminal 12 on X2 = exit - high during modulus execution; if a digital lock command is transmitted during execution of the modulus it will be ignored.

The delay before digital locking varies by up to 2.048 msec max.

The following auxiliary parameters are utilised: Pr83, Pr84, Pr85, b91.10, b91.12.

It is assumed that parameter Pr34 is not used. The program is as follows:

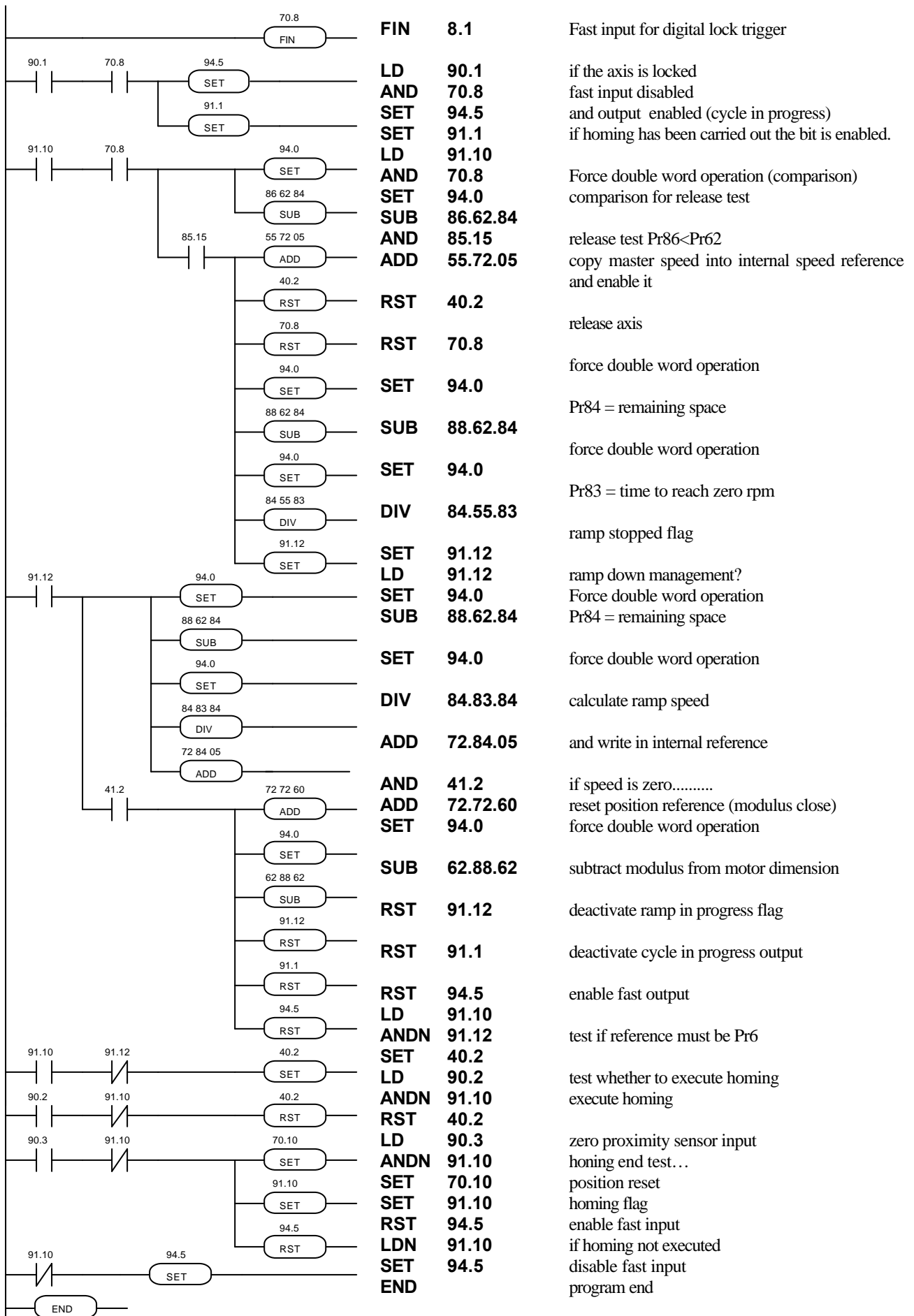

Example 9: movement with digital locking and return to origin

(FILE: E002.HPD)

To obtain the following functionality: with reference to the figure below assume there is a conveyor transporting product and a carriage running parallel to the conveyor and controlled by an HPD drive. On receipt of an external start command the carriage is aligned on a zero reference position (proximity sensor). With a second pulse command, provided by a product detection sensor, the drive locks on to the conveyor in order to perform an operation on the product at a precisely defined position; when this operation is terminated the carriage returns to its starting position.

In this case the program makes it possible to execute homing (see chapter 1) after which, on receipt of the manual command from the sensor, the carriage locks on and covers a distance equal to the value of Pr87:86; when this distance is reached the drive unlocks and stops according to the ramp programmed in parameter Pr83. The motor now automatically returns to the origin position executing a trapezoidal profile with the ramps set in Pr80 and the speed in Pr81. Note that one motor revolution corresponds to 4096 steps so the value to set in Pr87:86 should correspond to the number of steps of the motor shaft needed for the carriage to execute the required translation.

The master encoder on the conveyor shaft provides the drive with the necessary position reference during digital locking.

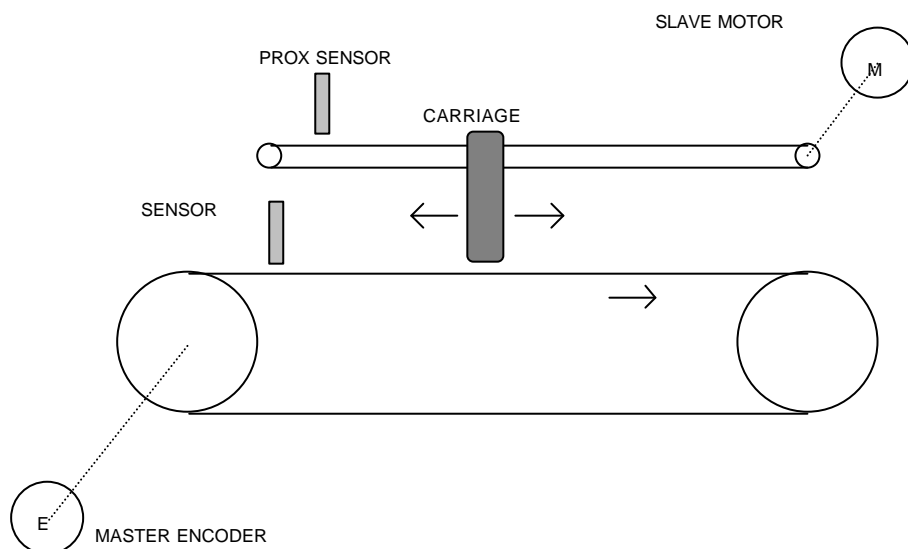

After having set the default values, program the following parameters:

Pr5=10 (homing speed), Pr31=10, b99.11=1, b40.2=1, b40.12=1, Pr80=trapezoidal profile ramp, Pr81=trapezoidal profile speed, Pr82=copy of P.51 in digital locking, Pr83=digital locking release deceleration ramp, Pr84=copy of Pr53 in digital locking, Pr87:86=release dimension in steps
 terminal 13 on X3 = pulse command for homing execution
 terminal 14 on X3 = axis zero position PNP proximity sensor
 terminal 12 on X3 = digital locking sensor pulse command
 terminal 12 on X2 = output; high during cycle execution; digital locking commands received during cycle execution will be disregarded.

The digital locking delay interval can be up to 6.144 msec.

The following auxiliary bits are utilised: b91.10, b91.12.

Program (see on next page) :

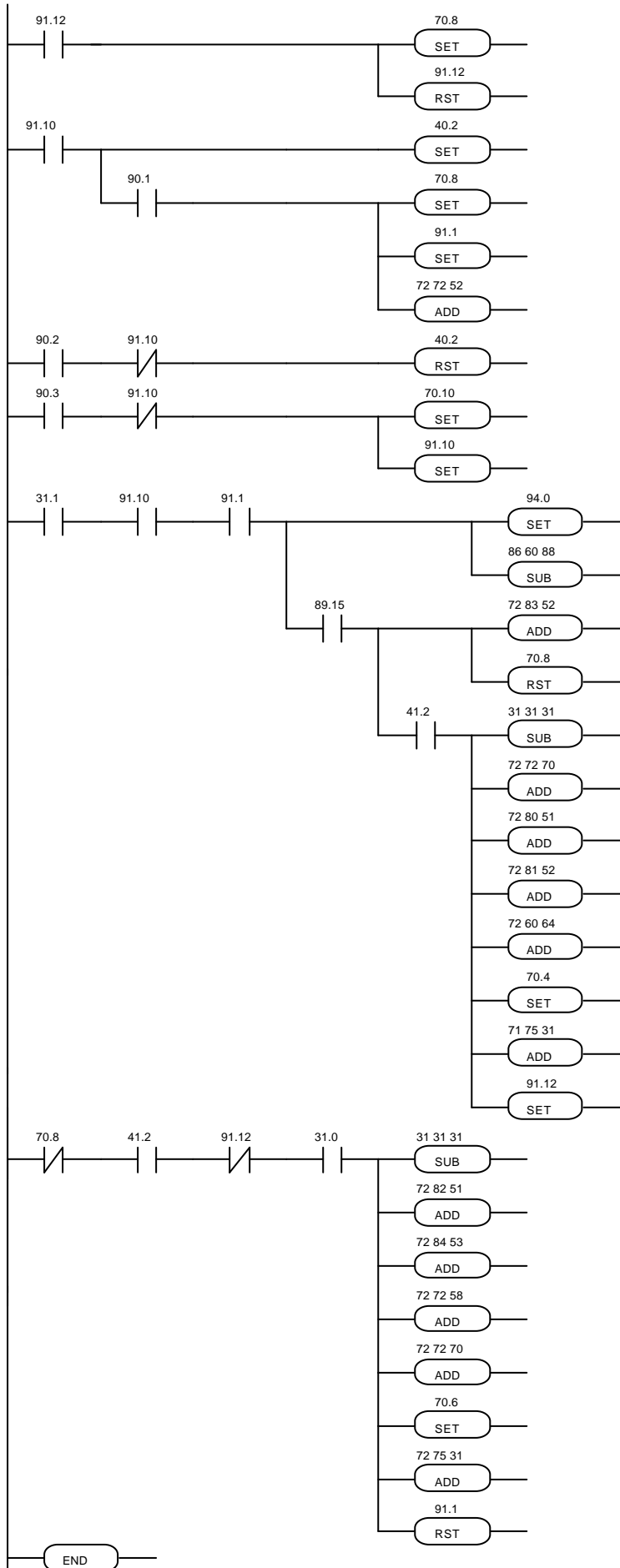

| | | |
|-------------|-----------------|------------------------------|
| LD | 91.12 | |
| SET | 70.8 | return start management |
| RST | 91.12 | with trapezoidal profile |
| LD | 91.10 | |
| SET | 40.2 | if homing exec. ref=pr6 |
| AND | 90.1 | locking start request |
| SET | 70.8 | locking |
| SET | 91.1 | cycle output on |
| ADD | 72.72.52 | no ramp pr52=0 |
| LD | 90.2 | |
| ANDN | 91.10 | homing request |
| RST | 40.2 | |
| LD | 90.3 | |
| ANDN | 91.10 | stand by for proximity |
| SET | 70.10 | reset dimensions |
| SET | 91.10 | homing exec. flag |
| LD | 31.1 | |
| AND | 91.10 | if OPM = 10 |
| AND | 91.1 | if homing is done |
| SET | 94.0 | and locked |
| SUB | 86.60.88 | forces double word |
| AND | 89.15 | release dimension reached ? |
| ADD | 72.83.52 | set release ramp |
| RST | 70.8 | and release axis |
| AND | 41.2 | if speed is zero |
| SUB | 31.31.31 | disable OPM |
| ADD | 72.72.70 | reset all b70 |
| ADD | 72.80.51 | trapezoidal profile ramp |
| ADD | 72.81.52 | trapezoidal profile speed |
| ADD | 72.60.64 | copy position in incremental |
| SET | 70.4 | dimension |
| ADD | 71.75.31 | and reverse for return |
| | | set OPM 9 |
| | | preset start |
| | | profile at next scan |
| SET | 91.12 | if no profile in exec. |
| LDN | 70.8 | Motor stopped |
| AND | 41.2 | no profile preset |
| ANDN | 91.12 | and OPM is 9 |
| AND | 31.0 | disable OPM |
| SUB | 31.31.31 | reset ratio |
| ADD | 72.82.51 | reset ratio |
| ADD | 72.84.53 | zero set slip |
| ADD | 72.72.58 | zero set all bits |
| ADD | 72.72.70 | |
| SET | 70.6 | enable feed forward |
| ADD | 72.75.31 | set OPM 10 |
| RST | 91.1 | zero set current cycle |
| END | | program end |

Example 10: Inter-Drive Communication

IDC (Inter Drive Communication) refers to a specific configuration of the serial port of the HPD drive that makes it possible to interchange parameters between two or more units.

With IDC enabled (Pr26=10) if bit b99.5 is set to 1 the HPD activates a broadcast command by sending the value of Pr81 to the address of Pr80. HPDs that receive broadcast commands with Pr26=10 automatically set b99.5 to 1 causing automatic transmission of Pr81 to the address of Pr80 in broadcast mode. Using this potential, it is extremely simple to connect two HPD drives in a loop via the serial ports, and a short program on the internal PLC will suffice to start transmission at power-on and restore it in the event of communication errors. The following example describes the PLC program required to copy Pr81 from the two drives in parameters Pr80.

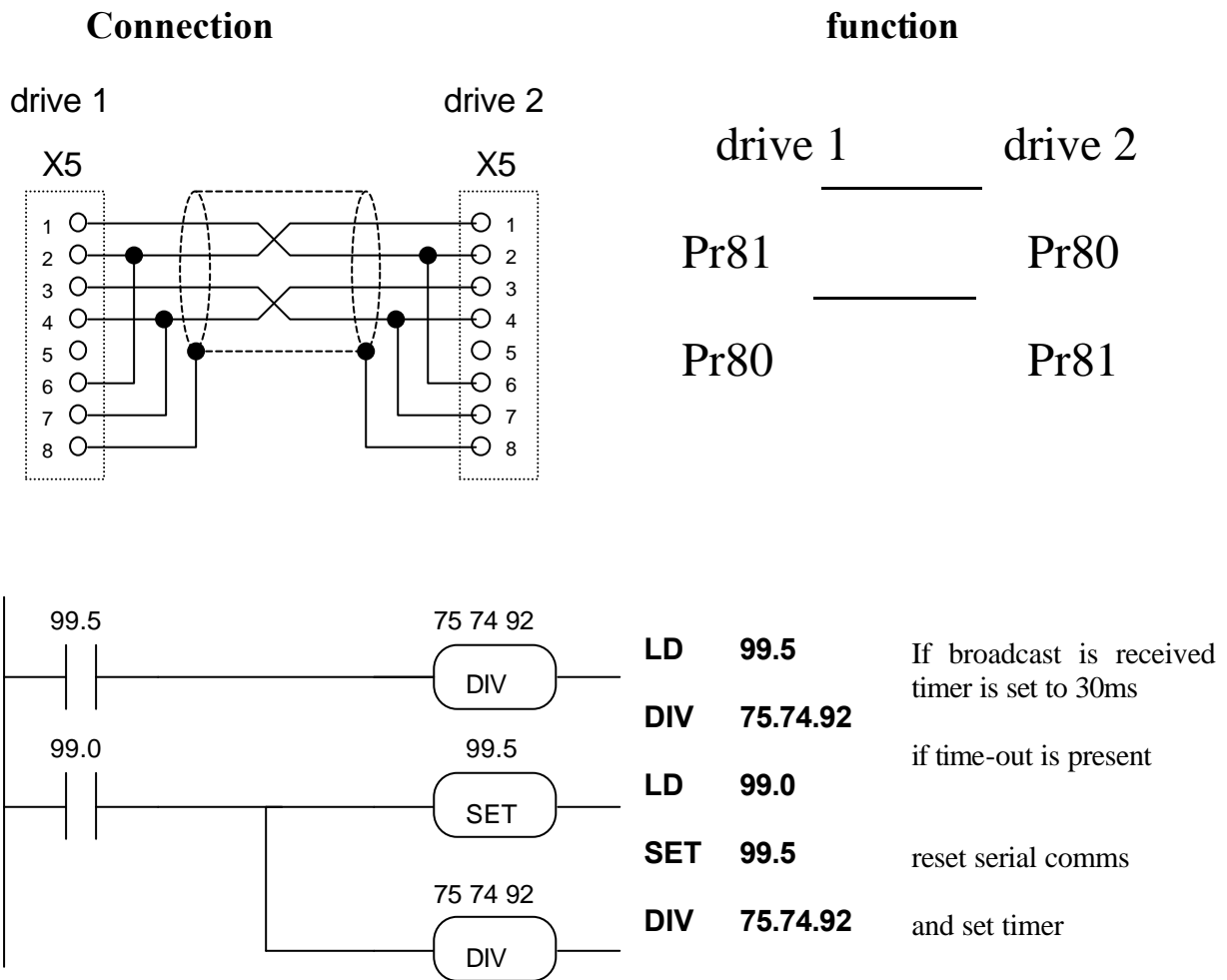

These PLC instructions must be entered on only one of the drives; both drives must have parameter Pr26=10 to enable the IDC function.

Example 11: automatic undervoltage alarm reset

In applications in which the auxiliary backup power supply is utilised it may be necessary to reset the undervoltage alarm automatically after power has been lost and restored. Simply set the following instructions in the PLC program:

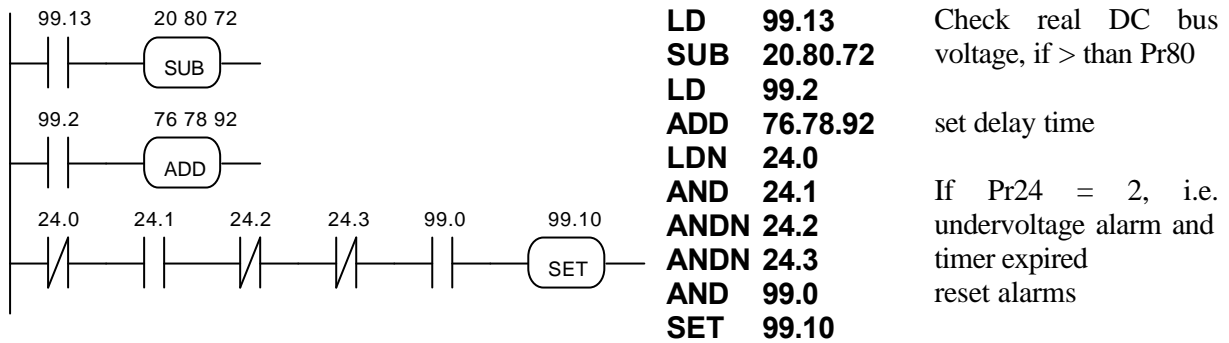

Only the undervoltage alarm (Pr24=2) is reset automatically; the nominal DC bus voltage -10% must be set in parameter Pr80 (for 380V~ power supplies Pr80=500); timer 1 must not be utilised in any other section of the pico-PLC program.

Example 12: 5 positioning with teach-in

(FILE: E003.HPD)

To obtain the following functionality: with reference to the figure, assume you need to acquire 5 different machine positions and then execute them automatically.

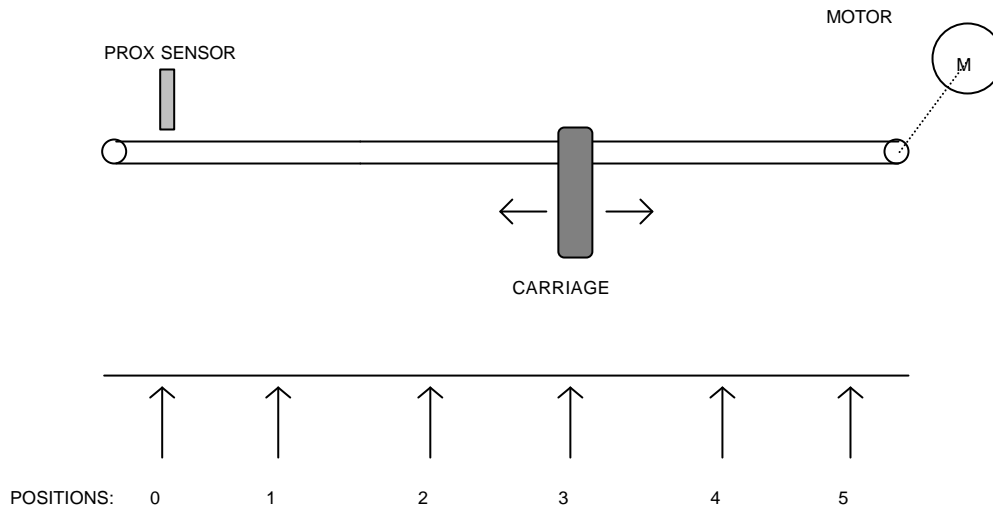

This can be achieved using a smart keypad module (see appendix L, SBC1 program) connected on the serial communications line with the drive and with the internal PLC. When the machine is powered up the drive will stand by to receive the homing exec command and the keypad will show the message “axis zero (F4)”. By pressing [F4] or sending a pulse command to digital input 2 of the drive, the motor shaft will turn at the speed established by parameter Pr5 until the intervention of the proximity sensor at digital input 3. The keypad display will now present the message “automatic dimension 1”; digital inputs 4, 5 and 6 select the position to be reached, while a pulse supplied to digital input 1 provides a trapezoidal profile to reach the selected position. The following table shows the relationship between parameters Pr80...Pr89 and the encoding of the 3 digital inputs; for example, input 4 on one selects position 1 and the distance in steps between the zero axis point and position 1 is set in Pr81:80, bearing in mind that one revolution of the motor shaft is equivalent to 4096 steps.

| Input 6 | Input 5 | Input 4 | position | dimension |
|--------------------|---------|---------|----------|-----------|
| 0 | 0 | 1 | 1 | Pr81:80 |
| 0 | 1 | 0 | 2 | Pr83:82 |
| 0 | 1 | 1 | 3 | Pr85:84 |
| 1 | 0 | 0 | 4 | Pr87:86 |
| 1 | 0 | 1 | 5 | Pr89:88 |
| other combinations | | | 0 | axis zero |

If you want to set the dimension from the keypad, press [F3] and the display will show the message “dimension xx yyyy” where xx defines the dimension in question and yyyy determines the relative value. The [+] and [-] keys are used to modify the value yyyy while [F3] changes the value xx.

If you wish to acquire the required position by moving the carriage, press [F1]: the display will show the message “manual dimension xx “; [F1] selects the xx dimension to be programmed while

[+] and [-] are used to move the carriage. The [+] key provides the motor start/stop in the positive direction, while [-] provides the start/stop in a negative direction; the translation speed in this case must be set in parameter Pr4. Once the required position has been reached, press [C] to confirm the dimension. Press [F2] to set automatic mode.

To store the parameters you have programmed press [S].

After having set the default values, set the following parameters on the HPD drive:

Pr4=10 manual translation speed

Pr5=5 homing speed

Pr31=9, b99.11=1, b40.2=1, b40.12=1

Pr81:80=dimension 1

Pr83:82=dimension 2

Pr85:84=dimension 3

Pr87:86=dimension 4

Pr89:88=dimension 5

terminal 12 on X3 = pulse command - execute positioning

terminal 13 on X3 = pulse command - execute homing

terminal 14 on X3 = PNP zero axis proximity sensor

terminal 15 on X3 = select position

terminal 16 on X3 = select position

terminal 17 on X3 = select position

terminal 11 on X2 = output: high during homing

terminal 12 on X2 = output, high during positioning

terminal 13 on X2 = output, high during manual translation

The following auxiliary bits are utilised: b91.10, b91.11.

The program is as follows:

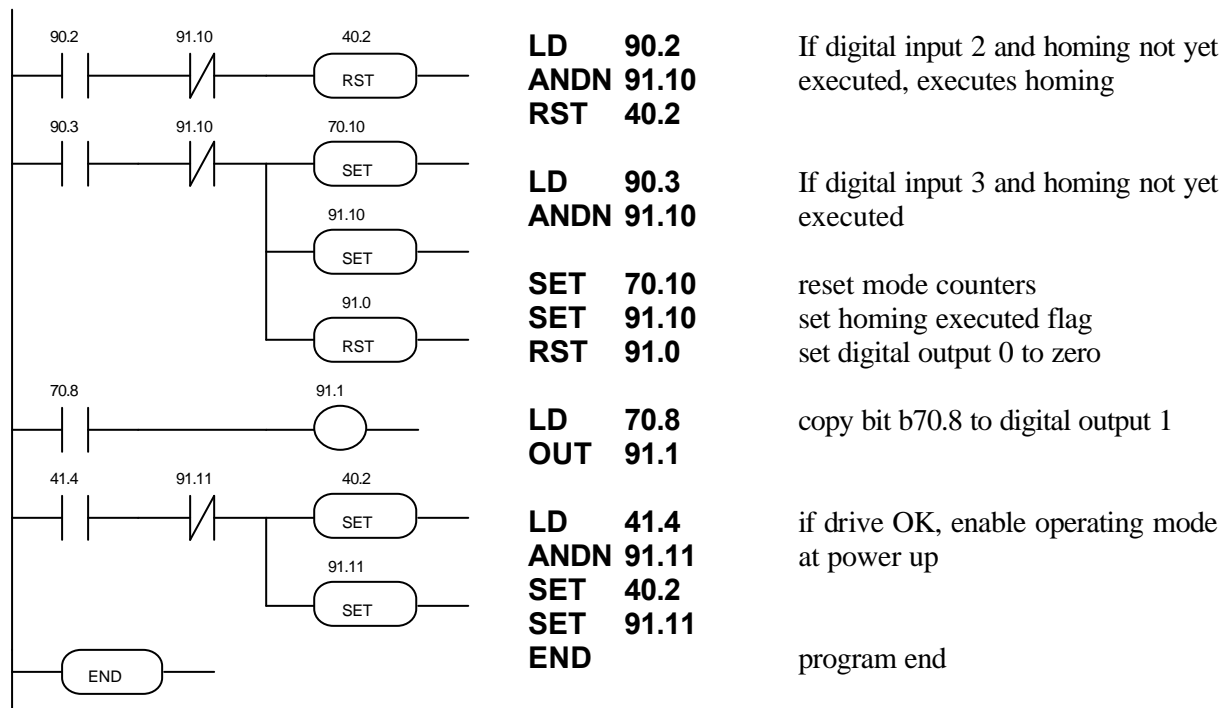

Inputs and outputs can be read and written directly via the serial communications line so there is no need to use the pico-PLC if you have an intelligent unit connected to the drive via the serial line. For more information regarding the serial line, refer to the HPD user manual.

Example 13: 5 positioning

(FILE: E004.HPD)

Referring to the figure below, assume you need to move the carriage to 5 different positions selected by means of three digital signals.

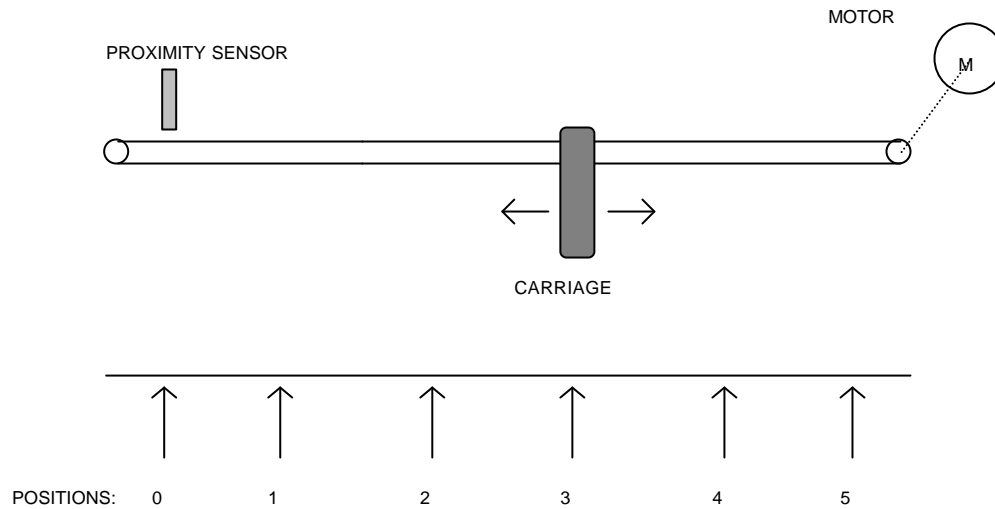

The positions are set in parameters Pr80...Pr89 in resolver steps taking the position of the proximity sensor as the zero value. When the machine is powered up the drive remains in standby mode awaiting the homing execution command: when a pulse command is supplied to digital input 2 of the HPD drive the motor shaft will turn at the speed set in parameter Pr5 until the proximity switch provides a signal at digital input 3. At this point digital inputs 4, 5 and 6 select the position to be reached, while a pulse on digital input 1 makes it possible to perform positioning on a trapezoidal profile. The following table shows the relationship between parameters Pr80...Pr89 and the encoding on the 3 digital inputs; for example, only input 4 on one selects position 1 and the distance in steps between the zero axis point and position 1 is set in steps, bearing in mind that one revolution of the motor shaft corresponds to 4096 steps.

| Input 6 | Input 5 | Input 4 | Position | Dimension |
|--------------------|---------|---------|----------|-----------|
| 0 | 0 | 1 | 1 | Pr81:80 |
| 0 | 1 | 0 | 2 | Pr83:82 |
| 0 | 1 | 1 | 3 | Pr85:84 |
| 1 | 0 | 0 | 4 | Pr87:86 |
| 1 | 0 | 1 | 5 | Pr89:88 |
| other combinations | | | 0 | axis zero |

After having set the default values, set the following parameters on the HPD unit:

Pr5=5 homing speed

Pr31=9, b99.11=1, b40.2=1, b40.12=1

Pr81:80= dimension 1

Pr83:82= dimension 2

Pr85:84= dimension 3

Pr87:86= dimension 4

Pr89:88= dimension 5

terminal 12 on X3 = execute positioning - pulse command
 terminal 13 on X3 = execute homing - pulse command
 terminal 14 on X3 = PNP axis zero proximity sensor
 terminal 15 on X3 = position selection
 terminal 16 on X3 = position selection
 terminal 17 on X3 = position selection
 terminal 12 on X2 = output, high during positioning
 The following auxiliary bits are utilised: b91.10, b91.11.
 Program:

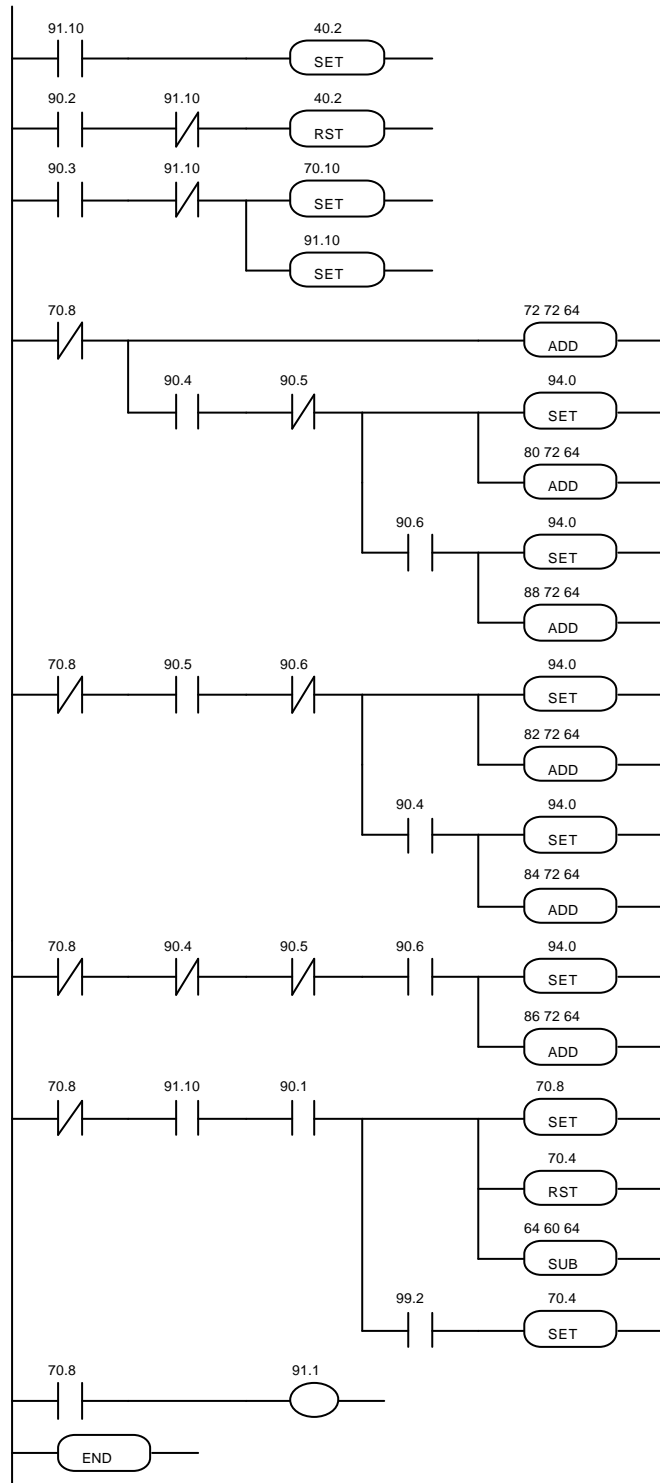

```

LD 91.10      If homing already
SET 40.2      executed enable operating
              mode

LD 90.2
ANDN 91.10   If digital input 2 execute
SET 40.2     homing if not yet done
LD 90.3
ANDN 91.10   if digital input 3 and
SET 70.10    homing not executed:
SET 91.10    reset counters
              homing exec flag
              digital output 0 at zero

LDN 70.8
ADD 72.72.64
AND 90.4     if profile terminated,
ANDN 90.5    select dimension
SET 94.0     according to the three
ADD 80.72.64 digital inputs
AND 90.6
SET 94.0
ADD 88.72.64
LDN 70.8
AND 90.5
ANDN 90.6
SET 94.0
ADD 82.72.64
AND 90.4
SET 94.0
ADD 84.72.64
LDN 70.8
ANDN 90.4
ANDN 90.5
AND 90.6
SET 94.0
ADD 86.72.64

LDN 70.8
AND 91.10
AND 90.1
SET 70.8
RST 70.4
SUB 64.60.64
AND 99.2
SET 70.4

LD 70.8
OUT 91.1
END
    
```

Example 14: reading 4-digit preselector (BCD Thumbwheels)

(FILE: E005.HPD)

To change the value of parameter Pr82 by means of a 4-digit preselector. This procedure involves the use of four digital outputs and four digital inputs:

terminal 12 on X2 = output for selection of first preselector digit (least significant)

terminal 13 on X2 = output for selection of second preselector digit

terminal 14 on X2 = output for selection of third preselector digit

terminal 15 on X2 = output for selection of fourth preselector digit

terminals 12...15 on X3 = inputs for reading digit in BCD (terminal 12 is least significant bit; connection diagram shown on next page).

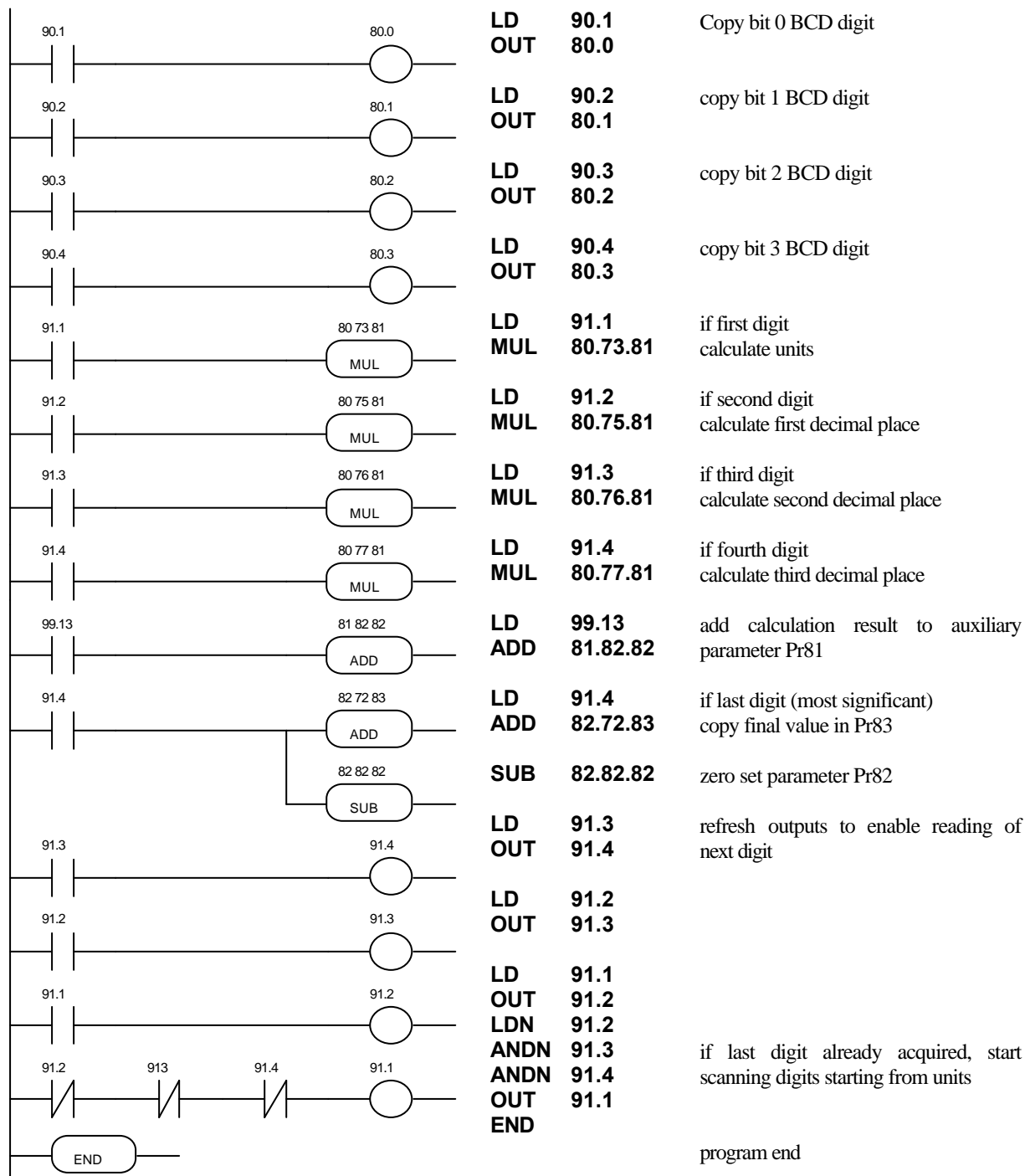

CONNECTION OF 4-DIGIT PRESELECTOR

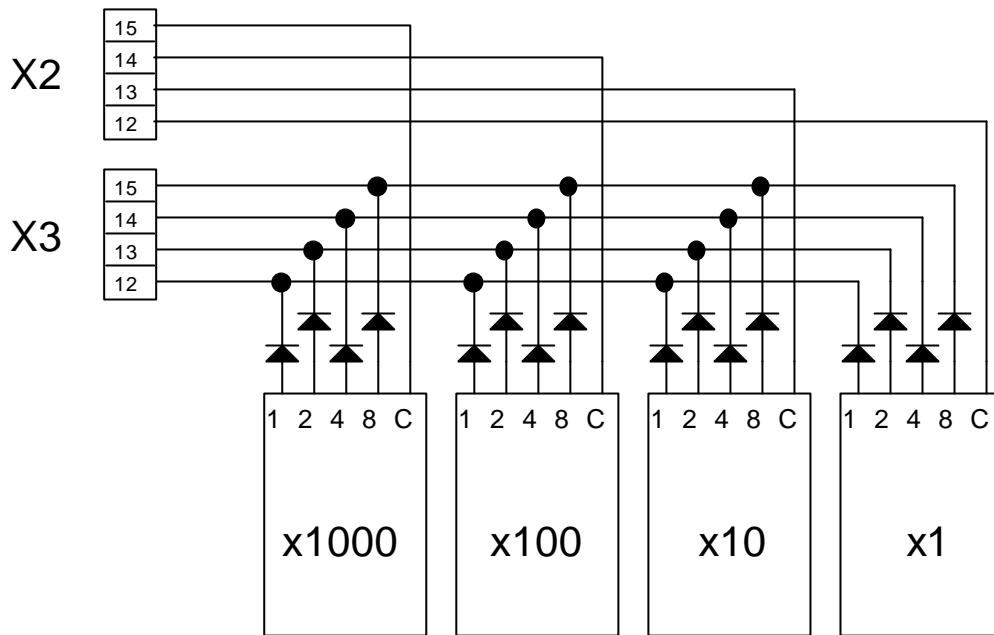

Example 15: programmable zero speed window

Assume you want the value of the main analogue reference to remain below a programmable threshold when it is cancelled. In practice, a speed window around zero rpm is defined within which speed is set to zero. The value of the threshold is set in parameter Pr88 in rpm; parameter Pr89 is used as an auxiliary memory area.

The required pico-PLC program is as follows:

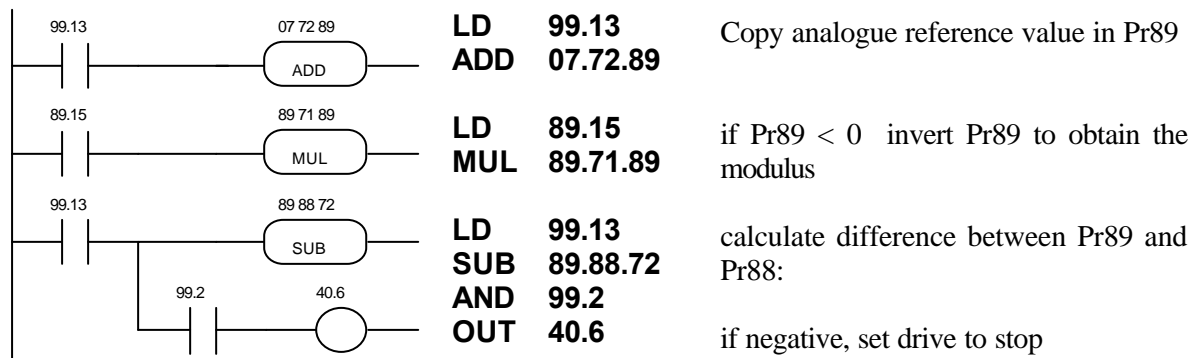



3.9 Programming with Pcbrush

The **HPD serial kit** is supplied to enable communication between a PC and the drive. The kit includes an RS-422/RS-232 converter, relative 230V~ power supply and serial connection cable. The enclosed communication software (supplied free of charge) designated **Pcbrush** has the following HW/SW requirements: 486 microprocessor or higher, *Windows* 3.1* or more recent version, mouse and serial port for drive connections. The main features of Pcbrush are:

- serial connection of up to 32 drives
- reading and setting of basic parameters and drive commands
- reading and setting of commands and parameters of operating modes
- functional block diagrams
- pico-PLC program displayed as ladder diagrams
- display of pico-PLC program status during operation
- I/O status
- file storage of parameterisation including pico-PLC program
- uploading of parameterisation including pico-PLC program from a file that can be selected from among those previously stored
- speed regulator and position controller simulation

PC - HPD connection layout (HPD serial kit):

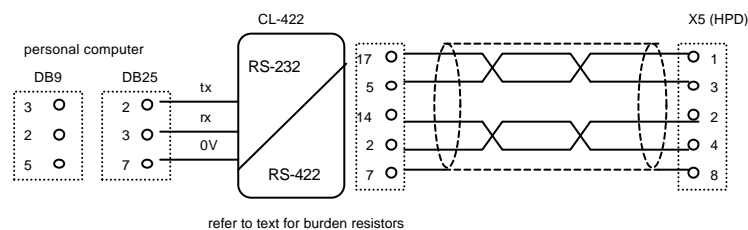

To create line load (burden) resistances, jumper pins 2 and 6, and pins 4 and 7 on connector X5 of the last drive on the serial line.

If the PC is a battery powered laptop (i.e. not connected to ground) use the following connection layout:

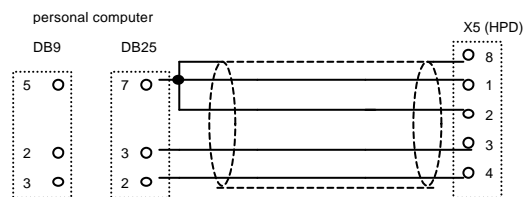

To install Pcbrush open *WINDOWS**, insert the diskette in drive A, select the *File* menu in Program Manager and then the *Run*.option. Now run Setup.exe on [A:] by typing the following string on the *Command line*: *A:\setup.exe* or by selecting the file with the *Browse...*button. The following installation procedure automatically creates a new icon for Pcbrush. Once the program is installed, launch it by double clicking the relative icon (or select the icon and then press ENTER). Set the following parameters on the drive: Pr26=6, Pr27=0, b40.14=1, b42.3=1.

* *Windows* and the Windows logo are registered trade marks or trade marks owned by Microsoft Corporation in the United States of America and/or other countries.

4 - SERIAL INTERFACE

The drive communication protocol is “master-slave” half-duplex type on an asynchronous RS-485/RS-422 line. The drives assume control of the line only following interrogation by the master.

Up to 32 drives can be connected on the same serial line, allocating each a different serial address in parameter Pr27. It is also possible to set transmission speed in parameter Pr26 as specified in the table:

| Pr26 (decimal base) | b/s | time-out (ms) |
|---------------------|------------|---------------|
| 0 | 600 | 512 |
| 1 | 1200 | 256 |
| 2 | 2400 | 128 |
| 3 | 4800 | 64 |
| 4 | 9600 (*) | 32 |
| 5 | 9600 | 32 |
| 6 | 19200 | 16 |
| 7 | 38400 | 12 |
| 8 | 57600 | 8 |
| 9 | 125000 | 4 |
| 10 | 57600 (**) | 8 |

(*) The version with code Pr26=4 differs from Pr26=5 because of the 25 ms response delay. This version was developed to interface with PLCs that require this characteristic.

(**) The version with code Pr26=10 was developed to allow data communication between two HPD drives.

Refer to the heading *Serial line connection* for connection diagrams.

4.1 Communication protocol

The right hand column in the table shows the time-out value in milliseconds for each communication speed; this is the time, starting from the beginning of each message (STX) within which the transmission of the message must terminate. Therefore, if the message is interrupted, after the time-out the drive will ignore the information already received and stand by to receive a new message.

Messages are made up of several consecutive data in the following format:

- 1 start bit
- 8 data bits following one byte between square brackets
- 1 parity bit (even)
- 1 stop bit

The message structure is:

[STX] [CMD+ADDR] [LUN] [PAR] [D0] ... [Dn] [CHK]

where:

[STX] = \$7E transmission start indicator. If a field other than STX should assume the value \$7E in the message, this field is followed by a (\$00) to ensure that it cannot be interpreted as an [STX].

[CMD+ADDR] = command and address of peripheral device, always different to zero. This datum is composed as follows: the first 5 bits (from 0 to 4) define the drive address (from 0 to 31); the remaining 3 bits (from 5 to 7) define the type of message, as described in the following table:

| CMD | bit 7 | bit 6 | bit 5 | message type |
|-----|-------|-------|-------|------------------------------------|
| 1 | 0 | 0 | 1 | drive response |
| 2 | 0 | 1 | 0 | read PLC instruction |
| 3 | 0 | 1 | 1 | write PLC instruction |
| 4 | 1 | 0 | 0 | read parameter |
| 5 | 1 | 0 | 1 | write parameter |
| 6 | 1 | 1 | 0 | bit change |
| 7 | 1 | 1 | 1 | broadcast parameters to all drives |

[LUN] = total number of bytes transmitted (parameter or PLC instruction); can assume values from 1 to 4. This value must not hold zero characters (\$00) after values that coincide with the initial transmission character (\$7E).

[PAR] = parameter or PLC instruction read/write address

[D0] ... [Dn] = datum transmitted.

[CHK] = 256 modulus sum of all fields except [STX] (checksum).

Message types

[CMD1] = drive response to data request, format:

[STX] [001+ADDR] [LUN] [PAR] [D0] ... [Dn] [CHK]

or confirm message in response to data entry or update, format:

[STX] [001+ADDR]

where ADDR identifies the answering drive.

[CMD2] = read message of PLC area instruction; format:

[STX] [010+ADDR] [LUN] [PAR] [CHK]

[CMD3] = write message of PLC area instruction; format:

[STX] [011+ADDR] [LUN] [PAR] [D0] ... [Dn] [CHK]

[CMD4] = parameter read message; format:

[STX] [100+ADDR] [LUN] [PAR] [CHK]

[CMD5] = parameter write message; format:

[STX] [101+ADDR] [LUN] [PAR] [D0] ... [Dn] [CHK]

[CMD6] = byte parameter bit change message; format:

[STX] [110+ADDR] [LUN] [PAR] [D0] [D1] [CHK]

In this case (LUN=2) two bytes are transmitted for the data: the first byte is the mask containing 0 in the positions of the bits to change and 1 in the other positions; the second byte contains 1 in bit positions to be set to 1 and 0 in the other positions. The address PAR corresponds to the parameter

(byte) in which one or more bits is to be modified. If the parameter is a word and the bit to be modified is among the first 8 (b0...b7): PAR = parameter address; otherwise if the bit to modify is one of the upper 8 (b8...b15): PAR = parameter address + 1.

[CMD7] = parameter write broadcast message to all drives connected to the serial line; format:

[STX] [11100000] [LUN] [PAR] [D0] ... [Dn] [CHK]

The address of peripheral device (ADDR) must be zero.

Notes:

- Parameters shown on the display with decimals must be treated as integer values, e.g. 978.5 will be read, and written, as 9785.
- All values preceded by the symbol \$ are hexadecimal numbers.
- The value in square brackets is the basic unit (byte) of the message.
- To be considered valid all messages must be terminated within a clearly defined time interval (time-out) which is a function of speed, and they must have correct parity and checksum.
- The drive responds to data requests or transmission only if the message is received correctly; if the message contains an error, no answer will be transmitted. The only exception is message type 7, with which a datum is transmitted with a single message addressed to all drives connected to the serial line.

Serial line initialisation and management

Drive serial communication can be enabled or disabled by means of bit b40.14.

The drive is factory set with b40.14=0, i.e. serial line disabled (default).

If you want to use the serial line first set the baud-rate in Pr.26; now set the serial address in Pr.27; finally, enable serial communication by setting b40.14=1 and initialise using b42.3. At this point you must save the configuration using command b99.15.

For parameter addresses and lengths refer to the relative table.

In the case of PLC instructions, each one occupies 2 or 4 bytes, the format of which is described below.

| | Instruction | code | length (bytes) |
|------|--------------------|-------------|-----------------------|
| LD | Pa.y | 0 | 2 |
| LDN | Pa.y | 1 | 2 |
| OUT | Pa.y | 2 | 2 |
| OUTN | Pa.y | 3 | 2 |
| AND | Pa.y | 4 | 2 |
| ANDN | Pa.y | 5 | 2 |
| OR | Pa.y | 6 | 2 |
| ORN | Pa.y | 7 | 2 |
| ADD | Pa, Pb, Pc | 8 | 4 |
| SUB | Pa, Pb, Pc | 9 | 4 |
| MUL | Pa, Pb, Pc | 10 | 4 |
| DIV | Pa, Pb, Pc | 11 | 4 |
| SET | Pa.y | 12 | 2 |
| RES | Pa.y | 13 | 2 |
| FIN | Pb40.y/Pb70.y | 14 | 2 |
| END | | 15 | 2 |

The memory area available for PLC instructions is 128 bytes, with addresses from 0h to 7Fh.

As the minimum length for each instruction is 2 bytes, the PLC program can hold a maximum of 64 instructions.

The first four bits of the first byte in each instruction (b0..b3) contain the instruction **code**.

For the first 8 instructions in the table (LD...ORN) and the SET and RES instructions, the remaining 4 bits of the first byte (b4..b7) contain the value **y**, while the second byte contains the value **Pa**.

For instructions ADD, SUB, MUL and DIV, the second byte contains the value **Pa**, the third **Pb**, and the fourth **Pc**.

The second byte is not utilised for the END instruction.

For the FIN instruction the fifth bit (b4) of the first byte selects the parameter: b4=0 refers to Pr.40, b4=1 refers to Pr.70; the sixth bit (b5) of the first byte is used for negative logic if required: b5=0 the bit is copied; b5=1 the bit is inverted and then copied. The second byte of the FIN instruction contains the value of **y**.

If FIN instructions are used they must be the first of the program and there must be no more than 3 so they will occupy addresses from 0h to 5h. If a FIN instruction is included from address 6h forward or, anyway, after any other instruction, it will be ignored (NOP).

The instructions must be one after the other starting from address 0h, without any free bytes.

There is just one program and it terminates with the END instruction.

Serial line application examples

For a better understanding of how to implement the serial line communication protocol, we have provided a few examples for each type of message.

The values are entered simply by way of example.

Case 1: reading a 1 byte parameter

Assume you want to read the value of parameter Pr.31 (operating mode), and that the value of this parameter is 9; assume the drive serial address is 0. The message to transmit is:

[7E][80][01][54][D5]

The drive answers with the message:

[7E][20][01][54][09][7E][00]

Case 2: reading a 2 byte parameter

Assume you wish to read the reference speed (Pr.7) and that the relative value is 2000; assume also that the drive serial address is 1. The message to transmit is:

[7E][81][02][42][C5]

The drive answers with:

[7E][21][02][42][D0][07][3C]

Case 3: writing a 1 byte parameter

Assume you want to select operating mode 1 (Pr.31); assume also that the drive serial address is 3. The message to transmit is:

[7E][A3][01][54][01][F9]

The drive answers with:

[7E][23]

Case 4: writing a 2 byte parameter

Assume you intend to set rated current at 25.3% (Pr.33); assume also that the drive serial address is 3. The message to transmit is:

[7E][A3][02][C6][FD][00][68]

The drive answers with:

[7E][23]

Case 5: setting a bit to 1

Assume you want to enter the command to save the PLC program (b99.14=1); assume also that the drive serial address is 0. The message to transmit is:

[7E][C0][02][93][BF][40][54]

The drive answers with:

[7E][20]

Case 6: setting a bit to 0

Assume you want to disable the drive by software (b40.9=0); assume that drive serial address is 0. The message to transmit is:

[7E][C0][02][5D][FD][00][1C]

The drive answers with:

[7E][20]

Case 7: writing a PLC instruction

Assume you want to set the first PLC instruction as: LD 90.4; assume the drive serial address is 0. The message to transmit is:

[7E][60][02][00][40][5A][FC]

The drive answers with:

[7E][20]

Case 8: reading the first PLC instructions

Assume you want to read the first instructions of the PLC default program; assume the serial address of the drive is 0. The message to transmit is:

[7E][40][04][00][44]

The drive answers with the message:

[7E][20][04][00][10][5A][A7][5A][8F]

which corresponds to the acquisition of the following instructions: LD 90.1, ORN 90.10.

4.2 Serial addresses and parameter lengths

| Parameter | Address | Length | Meaning |
|-----------|---------|--------|----------------------------------|
| Pr0 | 038h | 2 | motor speed in rpm |
| Pr1 | 034h | 2 | analogue reference |
| Pr2 | 03Ah | 2 | full scale 1 |
| Pr3 | 03Ch | 2 | full scale 2 |
| Pr4 | 036h | 2 | frequency full scale |
| Pr5 | 03Eh | 2 | internal reference |
| Pr6 | 040h | 2 | reserved reference |
| Pr7 | 042h | 2 | chosen reference |
| Pr8 | 0AEh | 2 | positive acceleration in seconds |
| Pr9 | 0B0h | 2 | positive deceleration in seconds |
| Pr10 | 0B2h | 2 | negative acceleration in seconds |
| Pr11 | 0B4h | 2 | negative deceleration in seconds |
| Pr12 | 0B6h | 2 | limit switch deceleration |
| Pr13 | 0B8h | 2 | overspeed threshold |
| Pr14 | 044h | 2 | top speed limit |
| Pr15 | 046h | 2 | lower speed limit |
| Pr16 | 048h | 2 | integral gain |
| Pr17 | 0BAh | 2 | damping factor |
| Pr18 | 0BCh | 2 | filter time constant |
| Pr19 | 0BEh | 2 | user current limit |
| Pr20 | 04Ah | 2 | DC bus voltage |
| Pr21 | 04Ch | 2 | reserved torque limit |
| Pr22 | 04Eh | 2 | auxiliary reference |
| Pr23 | 051h | 1 | current alarm code |
| Pr24 | 052h | 1 | previous alarm code |
| Pr25 | 053h | 1 | software version code |
| Pr26 | 05Eh | 1 | baud rate |
| Pr27 | 05Fh | 1 | serial address |
| Pr28 | 0C0h | 2 | shaft position (0..4095) |
| Pr29 | 061h | 1 | motor poles |
| Pr30 | 0C2h | 2 | resolver offset |
| Pr31 | 054h | 1 | operating mode |
| Pr32 | 0C4h | 2 | rated motor speed |
| Pr33 | 0C6h | 2 | rated current |
| Pr34 | 055h | 1 | scale factor for tacho generator |
| Pr35 | 0C8h | 2 | filtered torque request |
| Pr36 | 058h | 2 | i ² t accumulation |
| Pr37 | 05Ah | 2 | thermal image for braking |
| Pr38 | 0CAh | 2 | auxiliary analogue output |
| Pr39 | 0CCh | 2 | K for phase advance |
| Pb40 | 05Ch | 2 | flags used by main block |
| Pb41 | 056h | 2 | flags used by main block |
| Pb42 | 060h | 1 | flags used by main block |
| Pr50 | 064h | 2 | |

| | | | |
|------|------|---|---------------------------------|
| Pr51 | 066h | 2 | |
| Pr52 | 068h | 2 | |
| Pr53 | 06Ah | 2 | |
| Pr54 | 06Ch | 2 | |
| Pr55 | 06Eh | 2 | |
| Pr56 | 070h | 2 | |
| Pr57 | 072h | 2 | |
| Pr58 | 074h | 2 | |
| Pr59 | 076h | 2 | |
| Pr60 | 078h | 2 | |
| Pr61 | 07Ah | 2 | |
| Pr62 | 07Ch | 2 | |
| Pr63 | 07Eh | 2 | |
| Pr64 | 080h | 2 | |
| Pr65 | 082h | 2 | |
| Pr66 | 084h | 2 | |
| Pr67 | 086h | 2 | |
| Pr68 | 088h | 2 | |
| Pr69 | 08Ah | 2 | |
| Pb70 | 062h | 2 | flags used by operating mode |
| Pr80 | 0CEh | 2 | |
| Pr81 | 0D0h | 2 | |
| Pr82 | 0D2h | 2 | |
| Pr83 | 0D4h | 2 | |
| Pr84 | 0D6h | 2 | |
| Pr85 | 0D8h | 2 | |
| Pr86 | 0DAh | 2 | |
| Pr87 | 0DCh | 2 | |
| Pr88 | 0DEh | 2 | |
| Pr89 | 0E0h | 2 | |
| Pb90 | 0E2h | 2 | inputs |
| Pb91 | 08Ch | 2 | outputs |
| Pr92 | 08Eh | 2 | timer 1 |
| Pr93 | 090h | 2 | timer 2 |
| Pb94 | 032h | 1 | flags used by PLC |
| Pb99 | 092h | 2 | flags used for PLC and commands |

PLC area length: 128 bytes, addresses 00h to 7Fh.

Appendix A: HPD drive mechanical dimensions

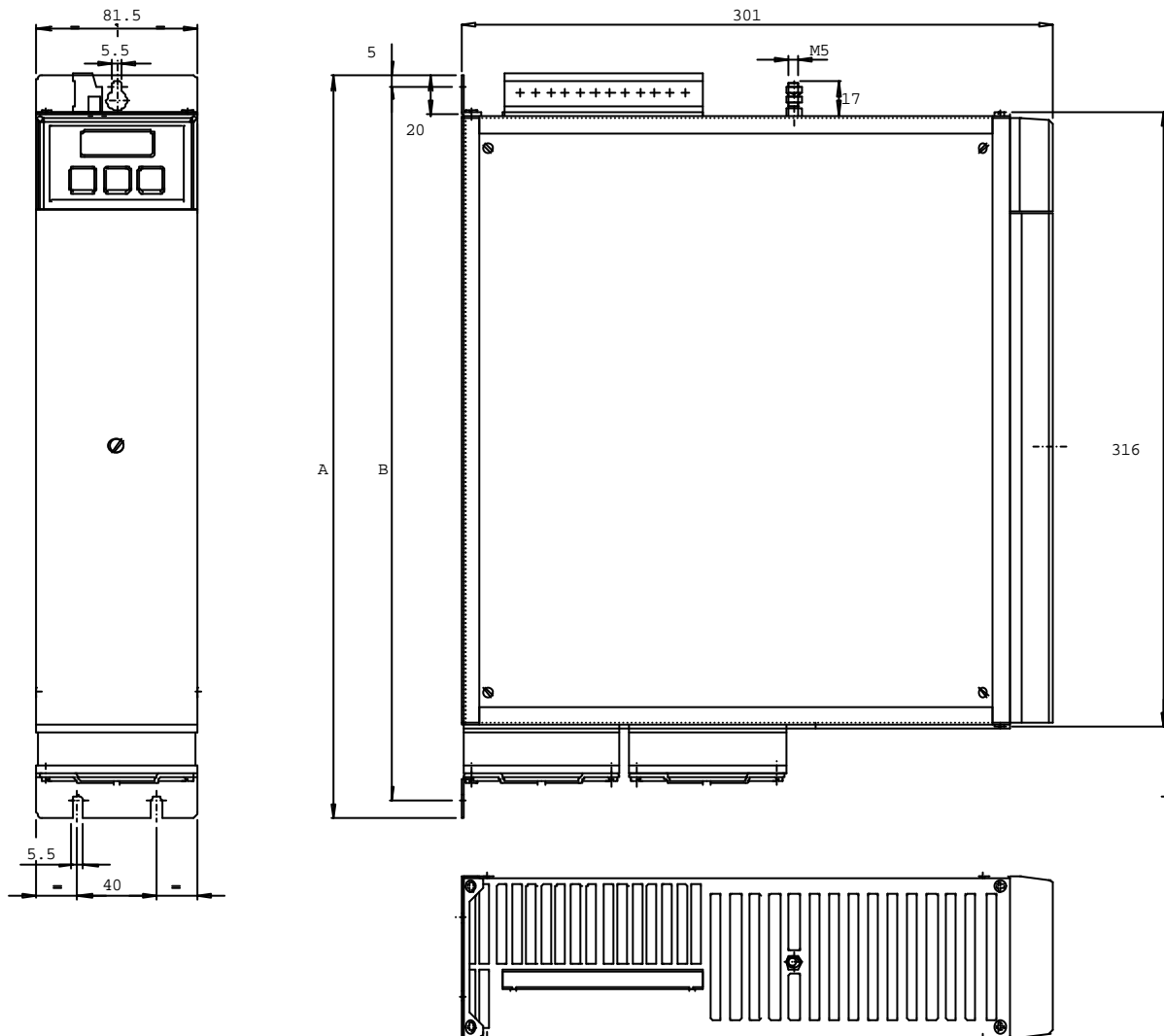

Dimensions can be changed at discretion of the manufacturer.

| drive type | A | B | weight kg |
|-------------------|-----|-----|-----------|
| HPD2 | 348 | 335 | 5.1 |
| HPD5, HPD8, HPD16 | 377 | 364 | 5.5 |

Appendix B: MB series motor connectors

CONNECTIONS FOR MBmax BRUSHLESS MOTORS

resolver

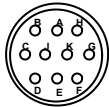

A= white-red = EXCT +
 B= white-yellow = EXCT -
 C= blue = Cos -
 D= yellow = Cos +
 E= black = Sin -
 F= red = Sin +
 G= Gnd (shield of cable)
 H= Gnd (shield of cable)
 K= PTC
 J= PTC

FAN MOTOR CONNECTOR FOR MBmax 105

CONNECTOR (Male)

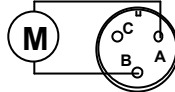

CONNECTOR (Female)

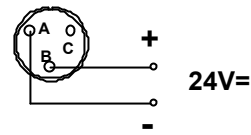

motor

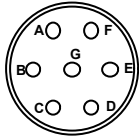

A = (white)
 B = (green) } motor
 C = (blue)
 D= Gnd
 E= Gnd
 F= Brake } 24V= ±10%
 G= Brake

FAN MOTOR CONNECTOR FOR MBmax 145 and 205

CONNECTOR (Male)

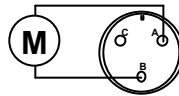

CONNECTOR (Female)

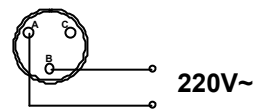

alternatively

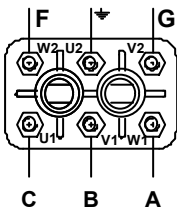

F - G = BRAKE

C-B-A = MOTOR



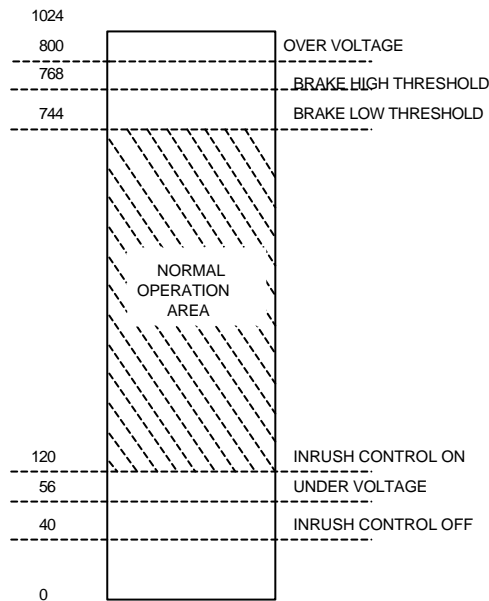

Appendix C: hardware characteristics

| digital input | | | |
|--|--|--------------------|------|
| input impedance | | 7 | Kohm |
| VH | | 15..30 | V |
| VL | | 0..3 | V |
| digital output | | | |
| type | | PNP open collector | |
| VH using internal supply | | 20..26 | V |
| IO for single output | | 100 | mA |
| IT current for all outputs using internal supply | | 200 | mA |
| IT current for all outputs using ext. supply +24 VIN | | 500 | mA |
| VSW max. voltage between out 6 A and out 6 B | | 110 | V~ |
| ISW max. current trough out 6 A and out 6 B | | 600 | mA |
| analogue reference | | | |
| type | | differential | |
| impedance | | 20 | Kohm |
| range | | ± 10 | V |
| CMMR | | > 60 | dB |
| resolution | | 15 | bits |
| aux. analogue input | | | |
| type | | differential | |
| impedance | | 250 | Kohm |
| range | | ± 10 | V |
| CMMR | | > 40 | dB |
| resolution | | 10 | bits |
| analogue output | | | |
| type | | single ended | |
| IO max. | | 1.5 | mA |
| range | | ± 10 | V |
| resolution | | 8 | bits |

Appendix D: DC bus voltage thresholds

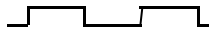

Appendix E: Standard settings

| | |
|--|--|
| Reference | Positive |
| Shaft moving | (motor shaft view) : clockwise |
| Torque monitor | Positive |
| R/D Counter | UP |
| Encoder out | A  B  |
| tacho signal | positive |
| Iu | $torque \cdot \sin(J)$ |
| Iv | $torque \cdot \sin\left(J + \frac{2 \cdot p}{3}\right)$ |
| IN AUX positive | Pr22 positive |
| Pr38 positive | OUT AUX. Positive |
| Encoder In. A  B  | Counter Up |

Appendix F: Software timers

| Time slot | Task running |
|------------------|-------------------------------|
| 256 μ s | Torque vector generation |
| 512 μ s | Speed loop |
| | Fast operating mode manager |
| | Torque limit evaluation |
| | Speed reference manager |
| | Brake resistor manager |
| | Fast input |
| 2.048 ms | Slow operating mode |
| 6.144 ms | Motor thermal image algorithm |
| | Digital input |
| | PLC instruction scan |
| | Digital output |
| 49.152 ms | Speed windows manager |

Appendix G: pico-PLC default program

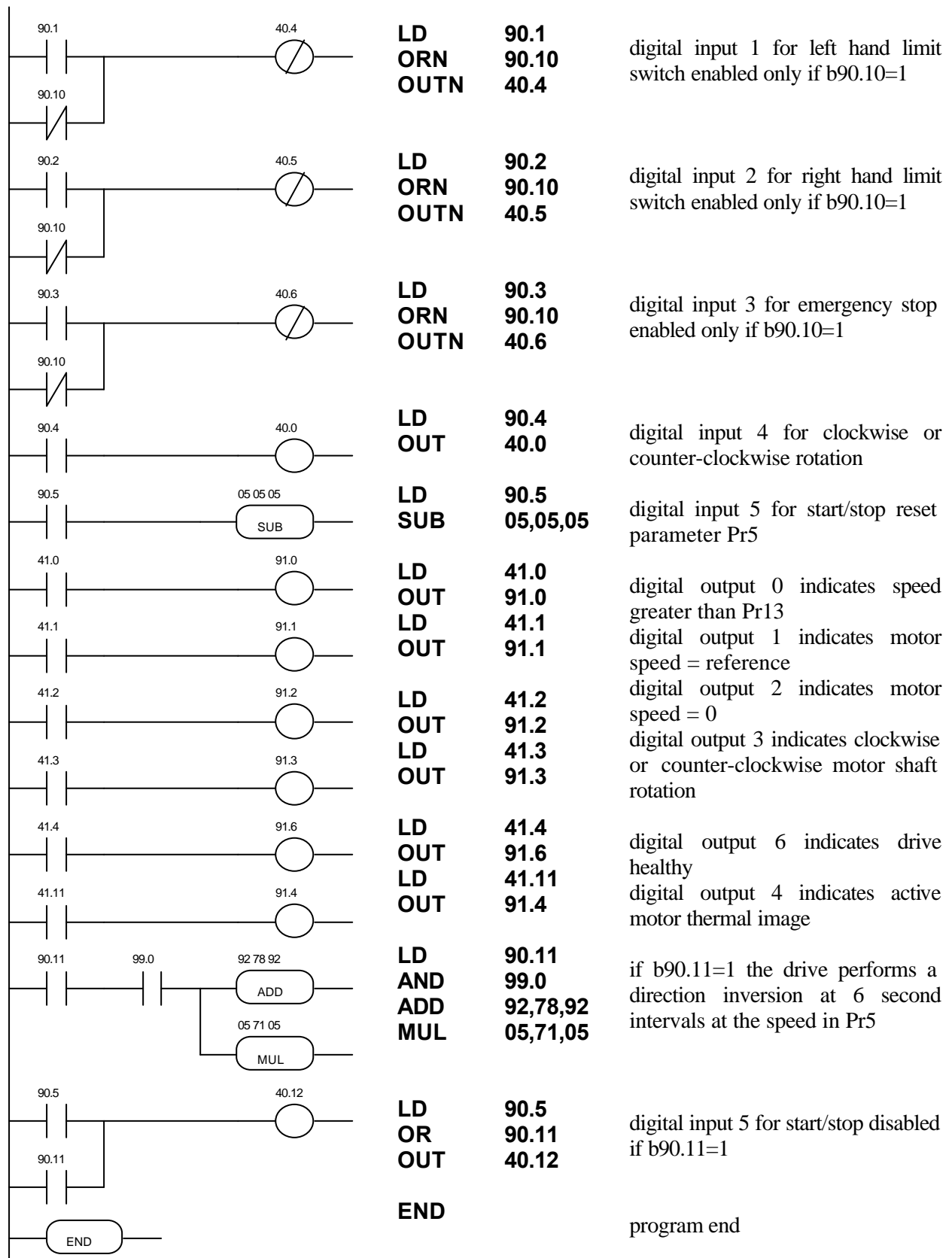

Appendix H: flash information

- USE b99.15 TO SAVE PARAMETERS
- USE b99.14 TO SAVE PLC PROGRAM
- TO CHANGE PLC INSTRUCTIONS b99.13 MUST BE AT 0
- WHEN CHANGING OPERATING MODE USE b99.11 TO LOAD DEFAULT PARAMETERS (b40.2=0)
- WARNING, BEFORE CHANGING Pr31 MAKE SURE b40.2=0
- SPEED REFERENCE IS LIMITED TO THE VALUE IN Pr32
- IN TORQUE CONTROL Pr2 AND Pr3 MUST BE SET TO 1000
- TO USE THE ACTIVE OPERATING MODE b40.2 MUST BE SET TO 1
- TO USE Pr32 TO CHANGE FEEDBACK RESOLUTION ON THE FLY, DISABLE TORQUE COMPENSATION (b42.6=0)
- IF YOU CANNOT UPDATE READ/WRITE PARAMETERS FROM THE KEYPAD, MAKE SURE b99.7=0. IF b99.7=0, THE PARAMETERS ARE PROBABLY MANAGED BY THE PLC PROGRAM.

Appendix I: S.B.C. filter mechanical dimensions

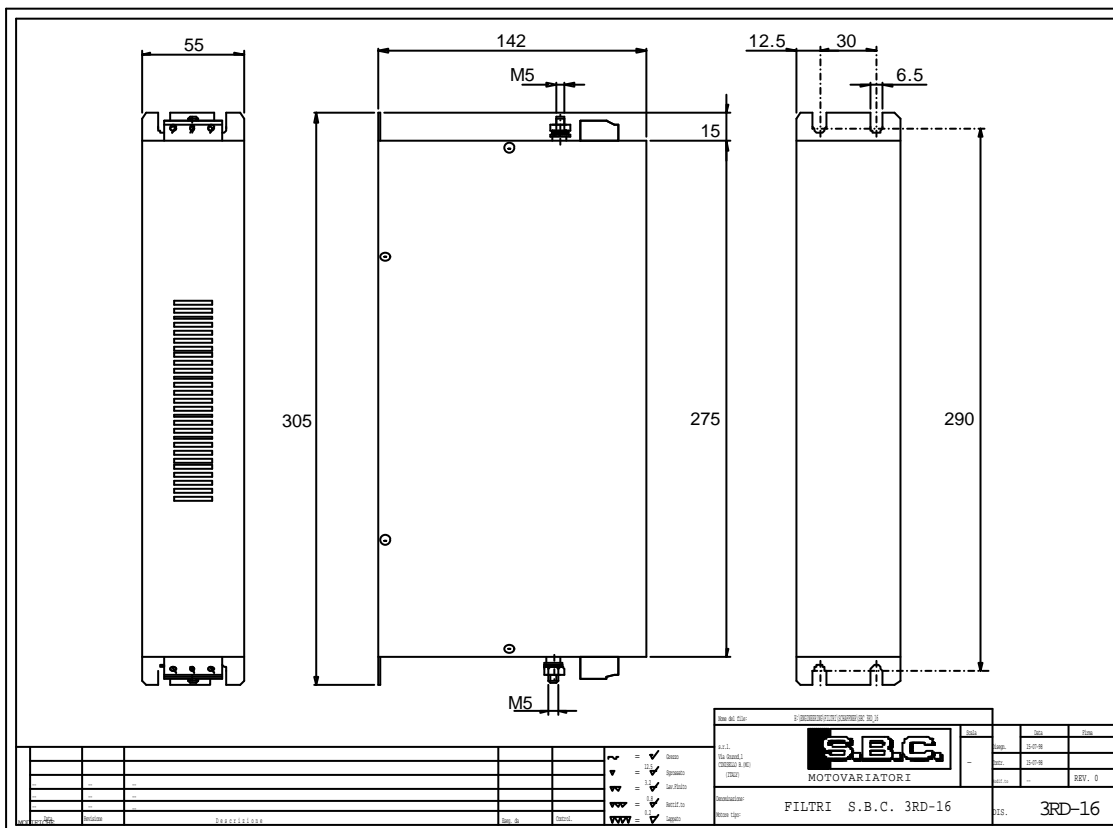
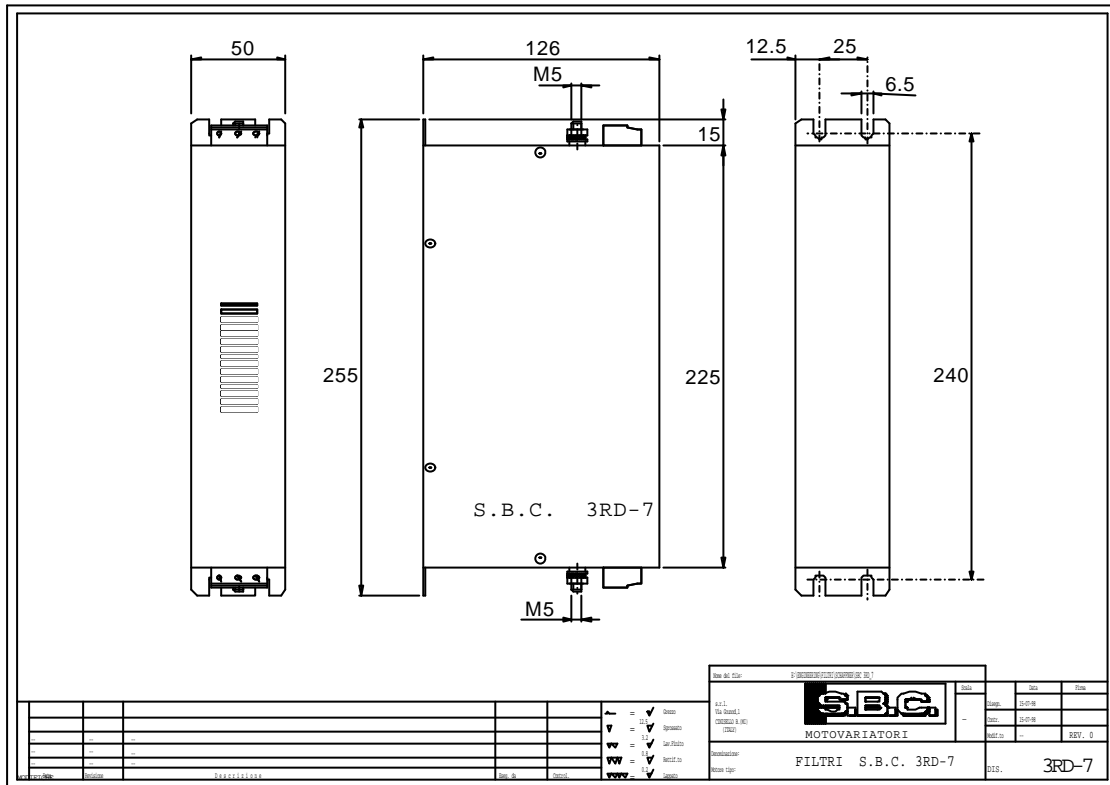

Appendix L: remote communications interface

If the application calls for a simple operator interface, use console 048+049+064. The console is connected to the drive by means of the serial line; it does not provide I/O capabilities and it does not have buffered memory. The connection cable is not part of the standard supply and the software must be generated by Parker, Divisione S.B.C. to client specifications.

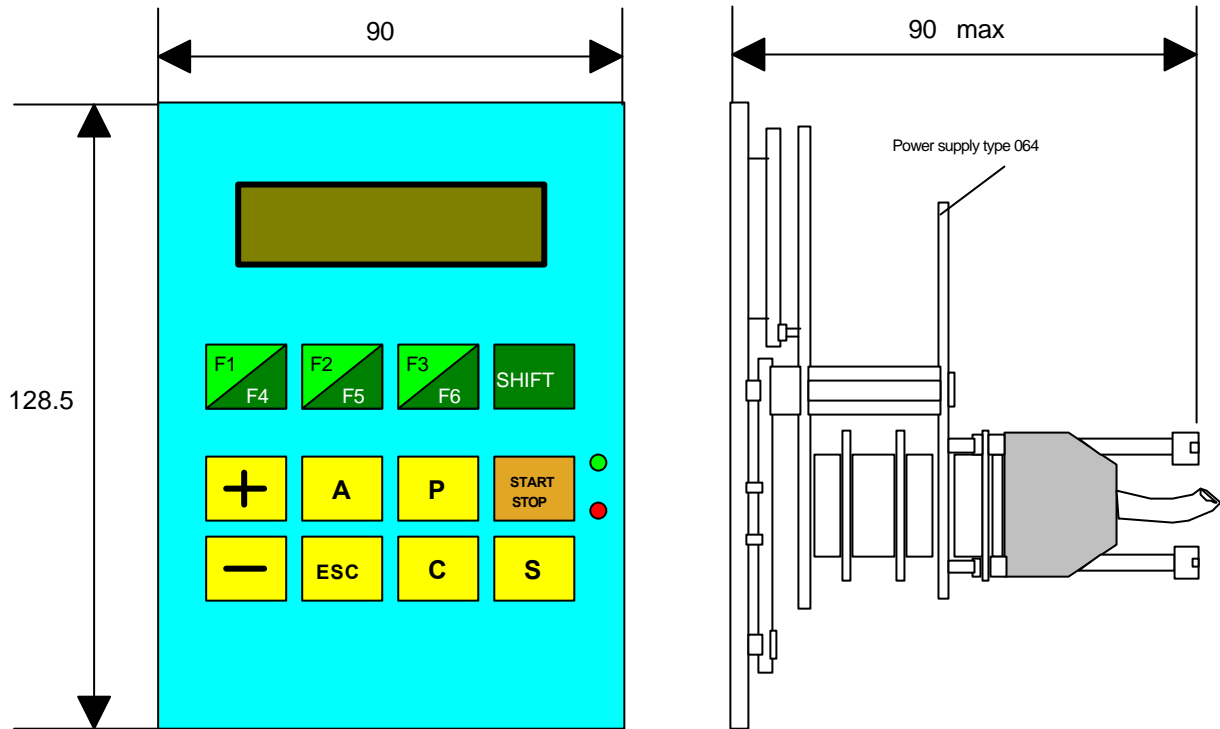

Rear panel view

HPD

X5

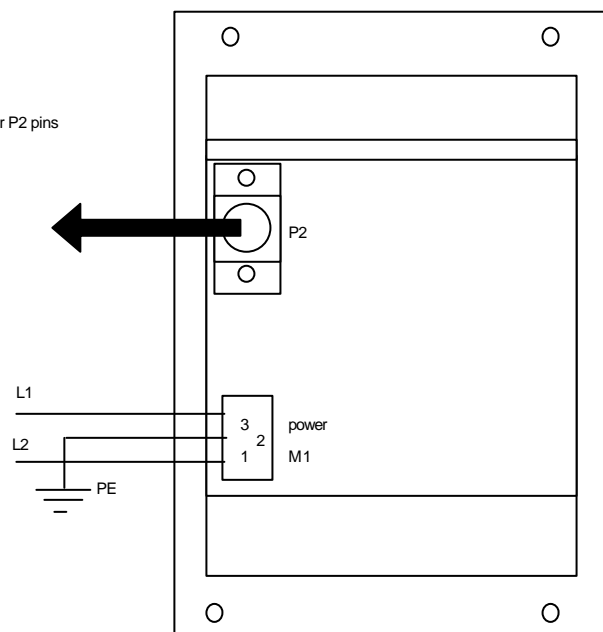
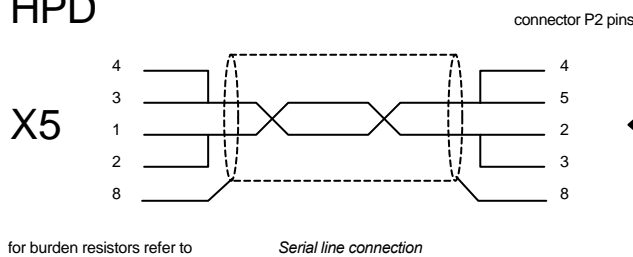

Appendix M: application description form

In order to develop our products in co-ordination with user's needs, we are most interested to learn about your HPD application. Please fill in this form and return it to us. This will also enable us to tailor our technical support to your individual requirements.

Fill in these forms in full and keep them with the machine technical documentation to facilitate maintenance.

to: *Parker Hannifin S.p.A. - Divisione S.B.C. / ITALY*
R & D department
 fax: +39-2-66016116

CUSTOMER name
 Contact name
 Tel.
 Fax.
 MODEL

- HPD 2
- HPD 5
- HPD 8
- HPD 16

SERIAL NUMBER
 MOTOR MODEL
 MOTOR SERIAL NUMBER
 OPERATING VOLTAGE V
 FIRST HPD APPLICATION? YES NO
 MACHINE TYPE
 TASK PERFORMED BY AMPLIFIER.....

COMMENTS

.....

FUNCTIONS USED

- | | | | |
|--|--|---|--|
| EXTERNAL BRAKING BACK-UP PARALLEL BUS MOTOR COILS | <input type="checkbox"/> MAINS FILTERS <input type="checkbox"/> LOW VOLTAGE FUNCTION <input type="checkbox"/> INTERNAL PLC <input type="checkbox"/> SERIAL LINE | <input type="checkbox"/> ENCODER IN <input type="checkbox"/> ENCODER OUT | <input type="checkbox"/> <input type="checkbox"/> <input type="checkbox"/> <input type="checkbox"/> |
|--|--|---|--|

AMPLIFIER CONTROLLED BY

| | MAKE | MODEL |
|-------------------|------|-------|
| NUMERICAL CONTROL | | |
| PLC | | |
| SINGLE AXIS CARD | | |
| MASTER/SLAVE CARD | | |
| OTHER..... | | |

| AMPLIFIER PROGRAMMING | | | | | | | |
|-----------------------|-------|-------|-------|-------|-------|-------|-------|
| Pr | value | Pr | value | Pr | value | Pr | value |
| 1 | | 31 | | 42.5 | | 70.6 | |
| 2 | | 32 | | 42.6 | | 70.7 | |
| 3 | | 33 | | 42.7 | | 70.8 | |
| 4 | | 34 | | 50 | | 70.9 | |
| 5 | | 39 | | 51 | | 70.10 | |
| 8 | | 40.0 | | 52 | | 70.11 | |
| 9 | | 40.1 | | 53 | | 70.12 | |
| 10 | | 40.2 | | 54 | | 70.13 | |
| 11 | | 40.3 | | 55 | | 70.14 | |
| 12 | | 40.4 | | 56 | | 70.15 | |
| 13 | | 40.5 | | 57 | | 80 | |
| 14 | | 40.6 | | 58 | | 81 | |
| 15 | | 40.7 | | 59 | | 82 | |
| 16 | | 40.8 | | 60:61 | | 83 | |
| 17 | | 40.9 | | 62:63 | | 84 | |
| 18 | | 40.10 | | 64:65 | | 85 | |
| 19 | | 40.11 | | 66:67 | | 86 | |
| 23 | | 40.12 | | 68:69 | | 87 | |
| 24 | | 40.13 | | 70.0 | | 88 | |
| 25 | | 40.14 | | 70.1 | | 89 | |
| 26 | | 40.15 | | 70.2 | | 99.5 | |
| 27 | | 42.0 | | 70.3 | | 99.6 | |
| 29 | | 42.1 | | 70.4 | | 99.7 | |
| 30 | | 42.2 | | 70.5 | | 99.13 | |

IF YOU USE AN INTERNAL PLC PROGRAM OTHER THAN THE DEFAULT PROGRAM, PLEASE ENCLOSE THE LISTING.

| | | | | | | | |
|-------|--|-------|--|-------|--|-------|--|
| In 0 | | In 16 | | In 32 | | In 48 | |
| In 1 | | In 17 | | In 33 | | In 49 | |
| In 2 | | In 18 | | In 34 | | In 50 | |
| In 3 | | In 19 | | In 35 | | In 51 | |
| In 4 | | In 20 | | In 36 | | In 52 | |
| In 5 | | In 21 | | In 37 | | In 53 | |
| In 6 | | In 22 | | In 38 | | In 54 | |
| In 7 | | In 23 | | In 39 | | In 55 | |
| In 8 | | In 24 | | In 40 | | In 56 | |
| In 9 | | In 25 | | In 41 | | In 57 | |
| In 10 | | In 26 | | In 42 | | In 58 | |
| In 11 | | In 27 | | In 43 | | In 59 | |
| In 12 | | In 28 | | In 44 | | In 60 | |
| In 13 | | In 29 | | In 45 | | In 61 | |
| In 14 | | In 30 | | In 46 | | In 62 | |
| In 15 | | In 31 | | In 47 | | In 63 | |