

## Hardware Reference

### Chapter Objectives

The information in this chapter will enable you to:

- Use this chapter as a quick-reference tool for most system specifications (environmental, I/O, pin outs, etc.)

### Environmental

- Operating Temperature: 36°F to 122°F (5°C to 50°C)
- Storage Temperature: -22°F to 185°F (-30°C to 85°C)
- Humidity: 0% to 95% non-condensing

### Electrical Specifications

#### RP240 Connector

The table below contains pin outs for the RP240's 4-pin Power and RS-232C connector on the back of the RP240. The pin out is listed from top to bottom.

Pin	Input/Output	Description
1	IN	Ground
2	IN	Receive (Rx)
3	OUT	Transmit (Tx)
4	IN	+5VDC

#### Power

You must supply 5 VDC  $\pm$ 2% to pin 1 of the RP240. The power supply must be capable of providing 100 mA of current. You can use the 5 VDC power supplies on board the SX, ZX, or 500 Indexer provided there is enough current remaining. The 6000 Series products have no current restrictions. Current levels are shown in the table below.

	Current Requirements			
	Available	Encoder	I/O	RP240
<b>SX</b>	250 mA	150 mA	10 mA each	100 mA
<b>ZX</b>	500 mA	150 mA	0 mA	100 mA
<b>500</b>	500 mA	150 mA	0 mA	100 mA

#### **CAUTION**

The SX's on-board power supply may not provide adequate current for the RP240 if the power supply is also providing power to an encoder and/or I/O.

#### RS-232C Communication

Refer to *Chapter ③ Installation* for RS-232C wiring instructions. RS-232C communication parameters for all Compumotor Controllers are fixed at:

- 9600 Baud Rate
- 8 Data Bits
- 1 Stop Bit
- No Parity

# Troubleshooting

## Chapter Objectives

The information in this chapter will enable you to:

- Isolate and resolve system hardware problems
- Isolate and resolve system software problems

## PROM Table

In order to use the RP240, the Extended X product must have a PROM with a revision greater than or equal to the ones shown in the table below. If your unit does not have the correct PROM, call the Compumotor Applications Department at 1-800-358-9070 for more information.

Description	PROM Number and Revision
Model 500	92-011512-01 C
Model 500-FOL	92-011513-01 C
SX Indexer/Drive	92-011640-01 C2
SXF Indexer/Drive	92-012039-01 C2
ZX/ZXF Indexer Drive	92-011492-01 D

## Troubleshooting

When your system does not function properly (or as you expect it to operate), the first thing that you must do is identify and isolate the problem. When you have accomplished this, you can effectively begin to resolve the problem.

The first step is to isolate each system component and ensure that each component functions properly when it is run independently. You may have to dismantle your system to detect the problem. If you have additional units available, you may want to exchange them with existing components in your system to help identify the source of the problem.

Determine if the problem is mechanical, electrical, or software-related. Can you repeat or re-create the problem? Do not make quick rationalizations about problems. Random events may appear to be related, but they are not necessarily contributing factors to your problem. Carefully investigate and decipher the events that occur before the subsequent system problem.

You may be experiencing more than one problem. You must isolate and solve one problem at a time. Log (document) all testing and problem isolation procedures. You may need to review and consult these notes later. This will also prevent you from duplicating your testing efforts.

If you are having difficulty isolating a problem, be sure to document all occurrences of the problem with specific information (time of occurrence, RP240 status, and anything else that was happening when the problem occurred).

Refer to the problem solutions contained in this chapter. If your system's problem persists, contact Parker Compumotor's Applications Department at (800) 358-9070.

## Reducing Electrical Noise

For detailed information on reducing electrical noise in your system, refer to the current Compumotor Catalog.

## Diagnostic LEDs

### RP240 Power LED

The RP240 has one LED indicator that can assist your troubleshooting efforts.

The power LED on the RP240 Main Unit indicates that the internal microprocessor is functioning properly. This two-color LED will be *green, red, or off.*

- GREEN The LED will be green if power is applied and the RP240 is functioning properly.
- RED The LED will be red if the microprocessor has failed.
- OFF The LED will be off if power is not applied to the RP240.

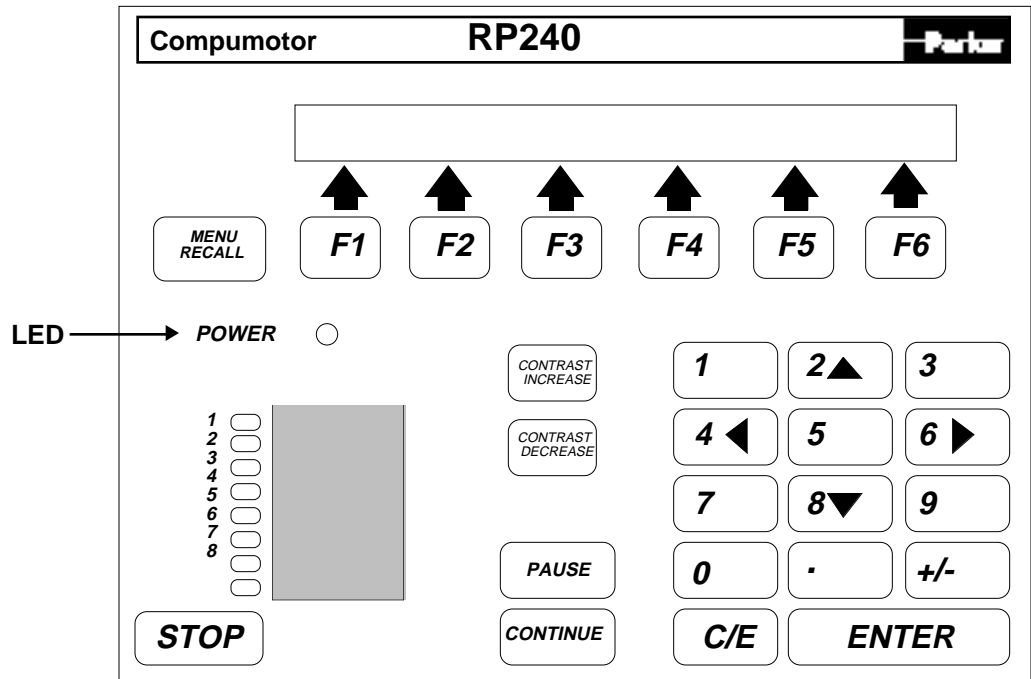

## Basic Troubleshooting Procedure

Answer the following questions when troubleshooting the RP240.

- ① Is the RP240 Status LED on and **green**? If it is off, the RP240 is not receiving the proper DC input voltage. Check the +5VDC power source to make sure it has the proper voltage. The input voltage should be between +5VDC  $\pm$  2%. The RP240 requires at least 100 mA of current to operate reliably. If the voltage is correct and the LED is off, call Compumotor's Applications Engineering Department (800-358-9070).

If Power LED is on and **red**, the internal microprocessor has failed. If possible, document what was happening when it failed (it may be helpful when you attempt to isolate the cause). Cycle power to the RP240. If the LED is still red, there is an internal failure in the unit. If the LED is green, the fault may have been caused by electrical noise.

## Common Problems & Solutions

The following table presents some guidelines to help you isolate problems with your motion control system.

- ❑ Look for the symptom that most closely resembles what you are experiencing.
- ❑ Look through the list of possible causes so that you better understand what may be preventing proper operation.
- ❑ Start from the top of the list of remedies and use the suggested procedures to try and isolate the problem.
- ❑ Refer to other sections of the user guide for more information on wiring, software commands, etc.

### Extended X

Symptom	Cause	Remedy
STOP key does not work.	STOP key is not enabled.	Enable STOP key with DSTP command.
	Two units daisy chained.	No remedy. STOP key only affects master unit in daisy chain.
When you press the STOP key, your program quits.	STOP key sends a K command.	This is correct.
PAUSE key does not work.	PAUSE key is not enabled.	Enable PAUSE key with DCNT command.
	Two units daisy chained.	No remedy. PAUSE key only affects master unit in daisy chain.
When you press the PAUSE key, your program quits.	Have not enabled Save Command Buffer on Stop (SSB) command.	Enable (SSH1) command.
	Have not enabled Save Command Buffer on Stop (SSH) command.	Enable command (SSH1).
PAUSE key does not pause motion.	Resume Execution (SSL) command has not been enabled.	Enable command (SSL1).
CONTINUE key does not resume program.	Save Command Buffer on Stop (SSH) and Resume Execution (SSL) commands are not enabled.	Enable commands (SSH1, SSL1).
DTEXT command does not display anything on the RP240.	RS-232C connection reversed or not connected.	Verify RS-232C connection.
	A space has been inserted between DTEXT and the text to be displayed.	Remove the space between command and the text.
After running a program with the RP240, cannot communicate with SX,ZX, or 500.	SX, ZX, or 500 is still running the program for the RP240.	Issue a K command, a SSAØ command, and an SSIØ command.
Function keys are not being read (No beeping).	Function keys are not enabled.	Enter a VARn=FUN statement before function key prompt in program.
Numeric keypad is not being read (No beeping).	Numeric keypad is not enabled.	Enter a VARn=NUM statement before keypad entry prompt in program.

### 6000 Series

Symptom	Cause	Remedy
When you press the STOP key, your program quits.	STOP key sends an !S command.	This is correct. If you would like the stop key to pause motion, refer to the COMEXS command.
PAUSE key does not pause motion.	PAUSE key sends !PS command.	This is correct. If you want to pause motion, use the STOP key in combination with the COMEXS command..
DWRITE command does not display anything on the RP240.	RS-232C connection reversed or not connected.	Verify RS-232C connection
After running a program with the RP240, cannot communicate with 6200 or 6250.	6200 or 6250 is still running the program for the RP240.	Issue an !K command, or press the STOP key.

## RS-232C Communications

👉 Helpful Hint: If you are having problems communicating with the RP240, use the following procedure to troubleshoot the communications interface.

- ① Make certain the transmit (Tx) of the host is wired to the receive (Rx) of the RP240 and the receive (Rx) of the host (SX, ZX, Model 500, 6200, 6250 or computer) is wired to the transmit (Tx) of the RP240.
- ② Make certain that the ground on the SX, ZX, Model 500, or other device is wired to the ground on the RP240.
- ③ Configure the host to the same baud rate (9600), number of data bits (8), number of stop bits (1), and parity (none) as the RP240.
- ⑤ Use DC common or signal ground as your reference, *not* earth ground.
- ⑥ Cable lengths should not exceed 50 ft. unless you are using some form of line driver, optical coupler, or shield. As with any control signal, be sure to shield the cable to earth ground at one end only.

## Editing Sequences—Extended X

If you wish to edit sequences in your SX, ZX, or Model 500 controller, you must re-establish RS-232C communication **before** downloading the new sequences to the controller. Compumotor recommends using the following procedure.

- ① Remove power from your controller and the RP240.
- ② Remove connections between the controller and the RP240.
- ③ Connect Rx, Tx, and Ground between the controller and your RS-232C port.
- ④ Apply power to your controller.
- ⑤ Enter the TERMINAL EMULATOR portion of your communication software (Compumotor's X-Ware is recommended).

Initially, you will not be able to establish communication if you have turned the echo (*SSA1*) command off in your power-up sequence.

- ⑥ If you are using X-Ware, *Device Not Ready* will appear on your screen (if you have disabled the command echo). Press the <ENTER> key. Next, press the **Y** key to enter Terminal Emulator.
- ⑦ To terminate the power-up sequence, and turn on the command echo as well as the interactive mode, issue the following commands:  

```
K <cr>  
SSA0 <cr>  
SSI0 <cr>
```
- ⑧ Check the controller's status by issuing an (*aR*) command, where the device address is *1R* <cr>. The controller should respond with a *\*R*. If you do not receive a *\*R*, consult the RS-232C Troubleshooting section of your controller user guide.
- ⑨ Edit the sequence as usual. If you are using X-Ware, press the <ESC> key, then use arrow keys to select the Editor menu.