

C H A P T E R 5

Hall Effect Sensors

The OEM770X works with three-phase brushless motors equipped with Hall effect sensors or equivalent feedback signals. In this chapter we will explain how Hall effect sensors are used in brushless motors, and how the OEM770X uses Hall effect outputs from Compumotor servo motors for commutation.

If you are using a motor from another vendor, obtain information about your motor's Hall signals and commutation sequence. Then use the information in this chapter to help you connect your motor to the OEM770X.

Hall Effect Sensors and Commutation

To move the rotor in the commanded direction, the drive will send current through two of the motor's stator coils. This current produces electromagnetic fields that develop a torque on the rotor, and the rotor turns. The rotor will stop if it can reach a position where its permanent magnets are next to the magnetic fields that attract them. Before the rotor can get to this position, though, the drive switches the current to a new combination of stator coils, and creates a new set of electromagnetic fields that cause the rotor to continue its movement.

The process of continually switching current to different motor coils to produce torque on the rotor is called *commutation*.

If the drive knows the position of the rotor's permanent magnets, it can set up magnetic fields in the stator that have the correct location and polarity to cause the rotor to turn. How can the drive know rotor position? Three Hall effect sensors located in the motor are affected by the rotor's permanent magnets. The three sensors transmit a unique pattern of signals for each rotor position. The drive uses these signals to determine the position of the rotor.

THE HALL EFFECT

Electrically charged particles moving through a magnetic field experience a deflecting force perpendicular to both the direction of their motion and the direction of the magnetic field.

The *Hall effect* is a phenomenon which shows that if a magnetic field is perpendicular to a thin strip of conductive material, and an electric current flows lengthwise through the strip, the mobile charges that carry the current will drift to one edge as they move along the strip.

In the example shown in the next drawing, assume that the conductive strip is metal. Electrons are the mobile charges. With a current i as shown in the drawing, the electrons will move upwards through the strip. In the presence of the magnetic field B , shown in the drawing, the electrons will drift toward the right edge of the strip.

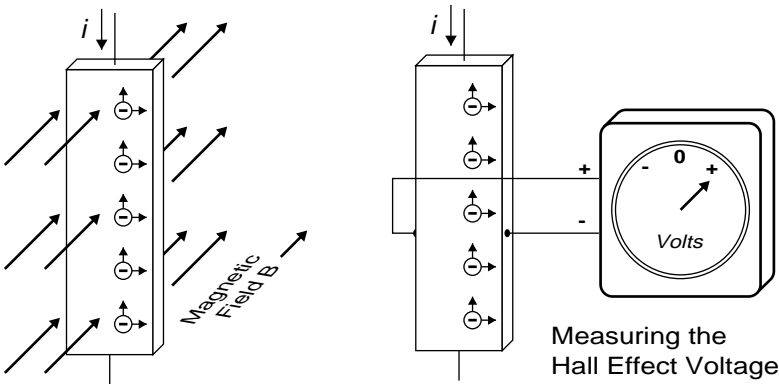

The Hall Effect

Because electrons are concentrated along one edge, there is a potential voltage difference across the strip. This voltage is known as the *Hall effect voltage*. The drawing shows a voltmeter connected across the strip to measure Hall effect voltage.

If the magnetic field is removed, the Hall effect voltage disappears. If the magnetic field is reversed, the Hall effect voltage will also be reversed.

HALL EFFECT SENSORS

Many types of sensors use the Hall effect to sense the presence of magnetic fields. The next figure is a conceptual drawing of a Hall effect sensor.

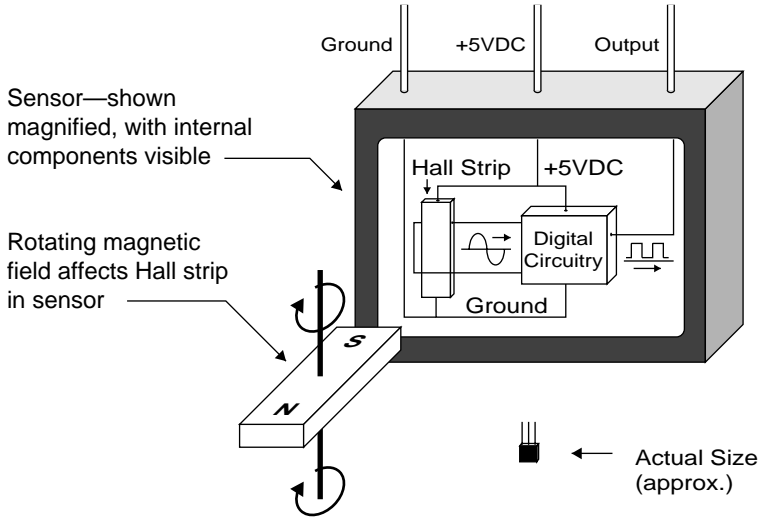

Hall Effect Sensor

A constant current runs through a conductive Hall strip inside the sensor. The drawing shows a rotating magnet near the sensor. The alternating field from this rotating magnet will cause an alternating Hall effect voltage to be generated across the strip.

This alternating voltage waveform is fed into circuitry that shapes the waveform. The output of the circuitry is a digital signal that is either +5VDC or 0VDC.

Sensors are available with a variety of output voltages and polarities. In the following discussion, we assume that the sensor is turned ON by a south magnetic pole, and remains on after the south pole is removed. When a north magnetic pole approaches, the north pole will turn the sensor OFF.

Note from the drawing that the sensor requires power connections for its internal circuitry (+5VDC and Ground). Also note that although the actual Hall effect voltage generated inside the sensor is an analog signal, the *output* from the sensor is a digital signal that is either ON or OFF.

HALL EFFECT SENSORS USED INSIDE BRUSHLESS MOTORS

There are three Hall effect sensors inside a motor. The next figure shows a conceptual drawing of the inside of the motor, and the three sensors.

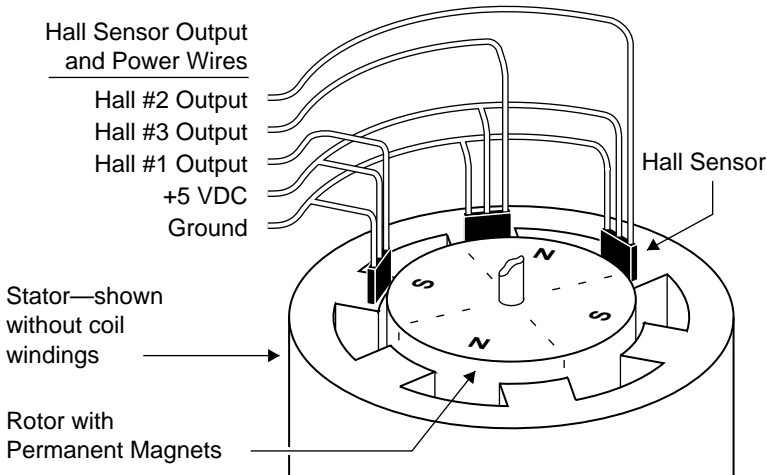

Hall Sensor Location (Shown Mounted Above Stator Pole Faces)

For clarity, the stator is depicted in simplified form, without its coil windings. The Hall effect sensors are located at one end of the stator, near the pole faces of the rotor. They are positioned approximately as shown in the figure.

Five wires are shown for making connections to the Hall sensors. Three wires are for individual outputs. The fourth and fifth wires are for +5VDC and Ground, which are internally connected to all three sensors.

Note that Hall #3 is positioned between Hall #1 and Hall #2.

Do Compumotor Motors Have Hall Effect Sensors?

Most Compumotor servo motors do not use Hall effect sensors. Instead, the motor's encoder has an extra *commutation track*, with three outputs. These outputs mimic signals that would be obtained from Hall sensors; in fact, the outputs are called *Hall outputs*. For conceptual reasons, in the discussion that follows we assume the motor contains Hall sensors. Keep in mind that no matter how the original signals are generated—from sensors or from an encoder—the result is the same: three output wires that deliver commutation information to the drive.

WINDINGS IN A THREE PHASE BRUSHLESS MOTOR

The next drawing depicts an end view of the motor, with the separate phase windings shown in their relative positions around the stator. The three phases share a center connection, as the detail within the dotted line shows.

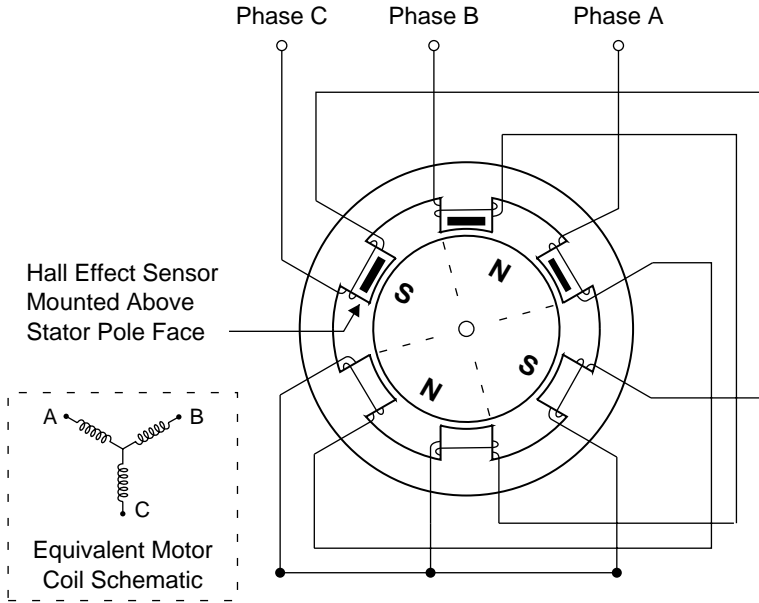

3-Phase Servo Motor with Hall Effect Sensors

The physical spacing of the Hall effect sensors is very important. Notice that one pole of the rotor can affect two sensors at the same time. In this drawing, the rotor's north pole is adjacent to both Hall 2 and Hall 3. Since south turns a sensor ON and north turns it OFF, the Hall outputs in this drawing would be 100. (In this example, 1 = ON and 0 = OFF. 100, therefore, means that Hall 1 is ON, Hall 2 is OFF, and Hall 3 is OFF.)

The OEM770X will send current into one phase and out of another—the third phase receives no current. When current flows through a phase, two magnetic poles of the same sign are formed on opposite sides of the motor. We will use the convention in these drawings that when current flows from the drive into a coil, it will produce a north pole. When it flows from a coil to the drive, it will form a south pole.

For example, suppose current goes into the motor through Phase A, and exits through Phase B. (Phase C has no current in it.) The current will flow

5 Hall Effect Sensors • OEM770X

through the windings in A and form north magnetic poles on opposite sides of the stator. The current flows through the center connection, and enters B's windings, where, because of the direction of the current, south magnetic poles are formed on opposite sides of the stator. (Refer to the previous drawing.)

From this example, notice that, although the stator has six locations for pole faces, there are only four poles at any one time. The other two pole faces have windings that carry no current—therefore no magnetic poles are formed by those windings.

THE SIX POSSIBLE HALL STATES

The next figure illustrates that, as the rotor turns, six different Hall states will be produced in a predictable and repeatable sequence.

This drawing shows the rotor, stator, phase coils, and Hall sensors. A small black dot has been drawn next to one of the south poles, to help show the motion of the rotor as it turns. (The two south poles in the rotor are actually indistinguishable from each other, as are the north poles.)

OEM770X • 5 Hall Effect Sensors

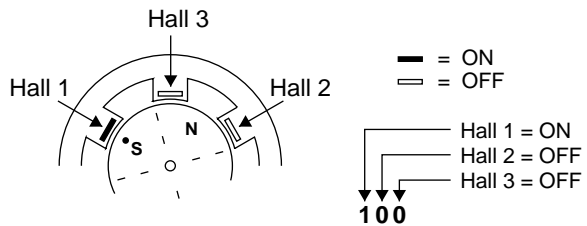
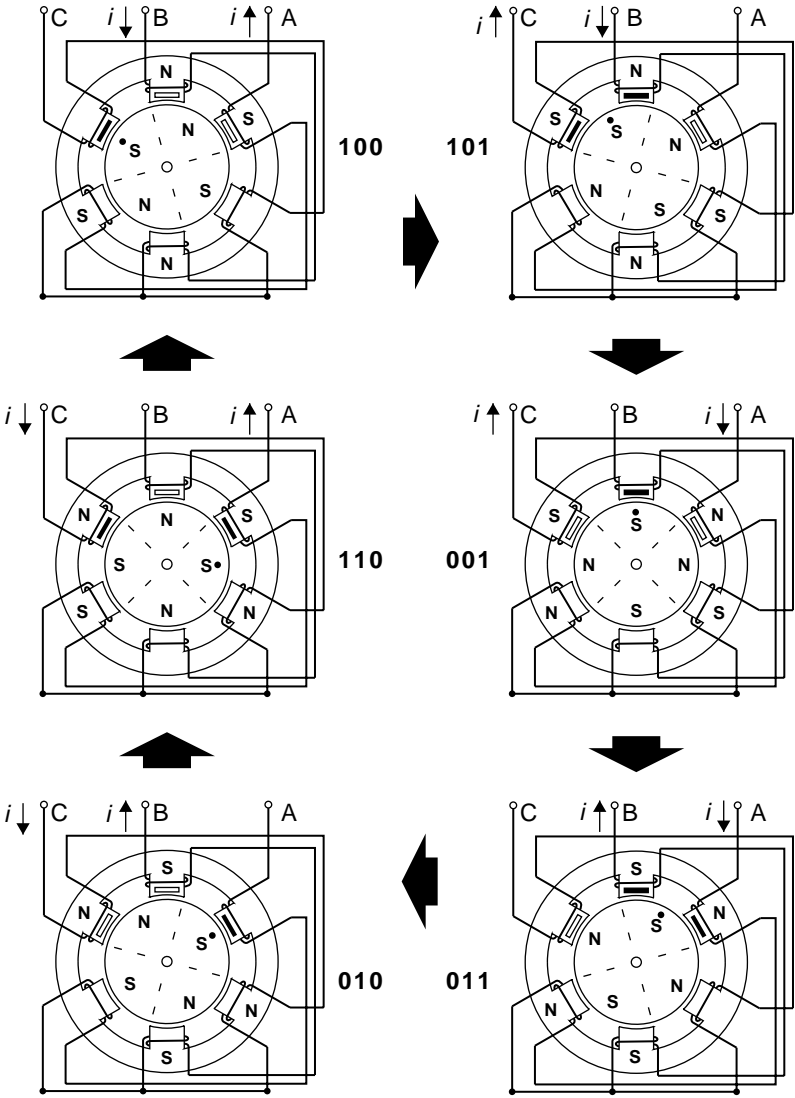

Hall Sensor States

5 Hall Effect Sensors • OEM770X

For each of the six different rotor positions in the drawing, a current is shown that will cause the rotor to rotate in a clockwise direction. The stator is labeled with N or S, to show the magnetic fields the current produces. These fields exert the torque on the rotor that causes it to move.

Each rotor position is labeled with its corresponding Hall state (100, 101, 001, etc.). These numbers represent the three Hall sensors, and whether they are on or off. The first digit corresponds to Hall 1, the second to Hall 2, and the third to Hall 3.

What voltage levels correspond to on and off? We use this convention:

- 1 = ON = +5VDC
- \emptyset = OFF = \emptyset VDC
- Voltage is measured at the OEM770X's Hall input, with the Hall wire connected to the input, and the drive turned on.
- If no drive is available, connect the Hall wire to a 1K Ω pullup resistor. Connect the resistor to +5VDC. Connect Hall +5 and Hall Gnd to your power supply. Measure the voltage at the point where the Hall wire is connected to the resistor.

To understand this drawing, examine the rotor position at Hall state 100. The south pole turns Hall 1 on. The north pole turns off Hall 2 and Hall 3. The Hall state, therefore, is 100. (Hall 1 = ON, Hall 2 = OFF, Hall 3 = OFF)

If current flows into phase B and out of phase A, north and south poles form in the stator. These poles exert a strong torque on the rotor's north pole, and it will turn clockwise.

If the rotor could turn far enough so that its north pole was aligned with the south pole in the stator, the rotor would stop. However, immediately before the rotor reaches this position, the Hall state changes. The south pole (with a dot on it, in this figure) moves into position next to Hall 3 and turns it on. The Hall state is now 101 (Hall 1 = ON, Hall 2 = OFF, Hall 3 = ON). Remember, Hall 3 is located between Hall 1 and Hall 2. See the detail at the bottom of the drawing.)

If current is now directed into phase B and out of phase C, a new set of magnetic fields forms in the stator that exert a strong torque on the rotor's south pole. The rotor moves further in a clockwise direction, and when it turns far enough, the Hall state changes to 001. At this point, directing current into phase A and out of phase C will keep the rotor turning to state 001.

The next Hall states the rotor will pass through are 010 and 110. When the south pole *without* the dot reaches state 100, a complete electrical cycle has occurred, and the rotor has rotated through 360 *electrical* degrees. (Physically, it has rotated through 180 *mechanical* degrees.) At this point, the same sequence of Hall states begins again.

Notice that the Hall states are not determined by the current flowing in the stator. They simply report information about the position of the rotor. Whether you turn the rotor by hand, or cause it to turn by directing current through the motor's coils, the Hall effect sensors are influenced only by the magnetic fields of the rotor.

The Hall effect outputs in Compumotor servo motors divide the electrical cycle into three equal segments of 120° (*electrical* degrees, not *mechanical* degrees). Outputs used in this arrangement are called 120° Hall effect outputs. The Hall states 111 and 000 never occur in this configuration.

Another arrangement, rarely used in modern servo motors, uses a 60° Hall effect sensor configuration, in which the states 111 and 000 can occur. Do not attempt to use such a motor with the OEM770X. It will not operate properly.

COMMUTATION BASED ON HALL STATES

The OEM770X monitors its three Hall inputs. It uses internal logic circuitry to assign a rotor position to each of the six Hall states, and then direct a motor current that results in rotor movement in the commanded direction.

The three Hall signals produced by clockwise shaft rotation are shown at the top of the next drawing. The Hall states are also listed, along with the table of phase currents the OEM770X uses for each Hall state.

5 Hall Effect Sensors • OEM770X

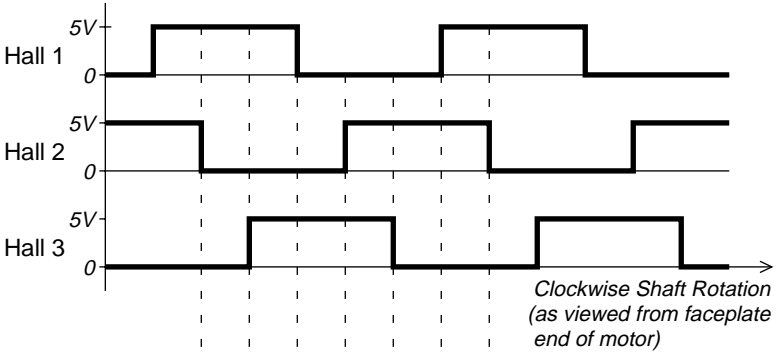

PHASE CURRENTS		
A	B	C
-	+	
+	-	
+	-	
+	-	
-	+	
-	+	

Commutation for Clockwise Shaft Rotation—Based on Hall States

For counterclockwise rotation, two changes are made. First, as the rotor moves counterclockwise, it passes through the same Hall states, but in the opposite order. (In this drawing, read the Hall states from the bottom up for counterclockwise rotation.) The drive sends currents through the same coils shown in this picture, but the direction of the current is reversed from that shown. As a result, a torque is produced in each state that causes the rotor to turn counterclockwise.

Connecting Motors from Other Vendors

The previous discussion described Compumotor servo motors, and how the OEM770X drive operates them. If you use a motor from another vendor, obtain information from the motor's manufacturer about its sequence of Hall states, commutation scheme, etc. Use the above information about Compumotor motors for guidance on how to connect your motor to the OEM770X.

IMPROPER WIRING CAN RESULT IN POOR PERFORMANCE

Assume that you arbitrarily connect your motor's three Hall wires to the OEM770X's Hall inputs. For any particular Hall wiring pattern, there are six different ways you can connect wires to Phase A, Phase B, and Phase C.

Of these six possible phase wiring combinations, only one will work properly. Three will not work at all. The other two deserve particular attention: if the motor is wired in one of these two configurations, the motor will turn, but its performance will be severely impaired.

How can you tell if your motor is wired improperly? If it is in one of the two poor-performance configurations, its torque will be much lower than the torque level of a properly wired motor. Also, torque ripple will be very pronounced as the motor turns.

The best way to determine whether or not your motor is wired correctly is to find the three wiring configurations that enable the motor to turn. Compare the motor's torque in each configuration. The configuration with the most torque will be the proper configuration.

TRIAL AND ERROR METHOD

You can use a trial and error method to connect your motor to the OEM770X. Follow these steps:

1. Arbitrarily assign numbers to your motor's three Hall output wires, and connect them to Hall 1, Hall 2, and Hall 3 on the OEM770X.
2. Connect Hall +5V and Hall GND.
3. Arbitrarily assign letters (A, B, C) to your motor's phase wires, and connect them to Phase A, Phase B, and Phase C on the OEM770X.
4. If the motor turns, find the best phase wiring configuration:
 - Move each phase wire over one position (A B C → C A B). Compare torque and torque ripple.
 - Move each phase wire one position further (C A B → B C A). Compare torque and torque ripple.
 - Use the wiring configuration that gives highest torque and lowest torque ripple.
5. If the motor does not turn, exchange two of the phase wires. The motor should now turn. Go to *Step 4*, compare the three wiring configurations that make the motor turn, and use the proper one.
6. If your motor turns in the opposite direction than you want, you can reverse it using one of several methods.
 - Reverse the command input wires.
 - Reverse the appropriate encoder connections.
 - Exchange two Hall input wires, then follow *Steps 2 – 5* above.