

CHAPTER 3

Specifications

Complete specifications for the OEM770X Drive and Parker Compumotor SM, NeoMetric, and J Series motors are listed in this chapter.

The motors are described by the following numbering system:

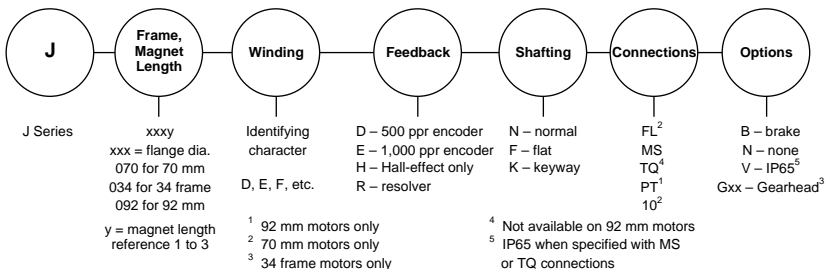
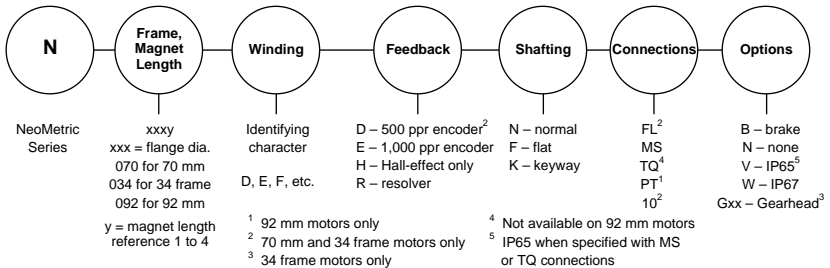
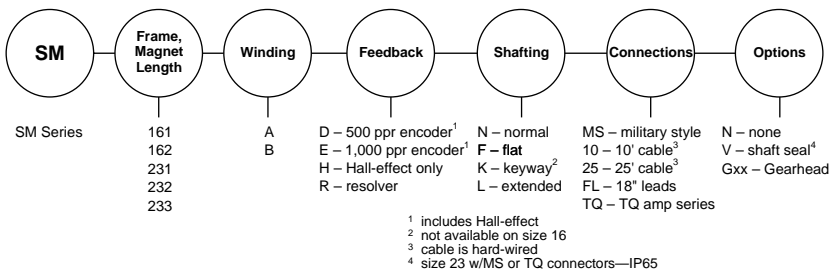

Specifications: OEM770X Controller/Drive

OEM770X Controller/Drive – Specifications		
POWER INPUT		
	Voltage	24-75VDC
	Current	Ø-12 amps
POWER OUTPUT—MOTOR		
	Peak Current	12A (approx. 2 sec maximum duration at 45°C ambient temperature. See <i>Current Foldback</i> for details)
	Continuous Current	6A
	Voltage	90VDC maximum
	Peak Power	840W (1.1 hp) (@75V supply voltage)
	Continuous Power	420W (0.56 hp)
	Switching Frequency	20 kHz
	Bandwidth	2 kHz typical (dependent on motor)
	Transconductance	1 volt = 1.2 amp
	Commutation	120° Hall Effect Sensors for Six-State Commutation Method, or Brushed DC Motor
	Short Circuit Protected	Yes
POWER OUTPUT—HALL EFFECT SENSORS		
	Voltage	+5VDC ± 0.5VDC
	Current	50 mA (maximum)
	Overload Protected	Yes
PERFORMANCE		
	Position Range	±1,073,741,823
	Velocity Range	0.01 to 200 rev/s
	Acceleration Range	0.01 to 9999 rev/s ²
	Velocity Accuracy	±0.02% of maximum rate
	Velocity Repeatability	±0.02% of set rate
INPUTS		
	General Purpose Inputs	5 user defined inputs
	Limit Inputs	2 hardware limits
	Enable Input	Active LOW: Ø-0.8V @ 2mA When disabled: Internal 2.49 KΩ pullup resistor to +5VDC
	Encoder	2-phase differential (recommended) or single ended (+5VDC TTL compatible). 960 kHz maximum frequency.
HALL INPUTS		
	Low State	Ø-0.8V
	High State	Internal 1 KΩ pullup resistor to +5V
	Input Frequency	Ø-2 kHz maximum

OEM770X Controller/Drive – Specifications (contin.)

OUTPUTS

General Purpose	2 user defined general purpose outputs
Fault Output	Active HIGH: open collector output Inactive LOW: \emptyset -0.4VDC at \emptyset -20 mA
Current Monitor	-10V to +10V analog voltage Scale: 1V corresponds to 1.2A output Output Impedance: 10 K Ω
LEDs	GREEN = power; RED = various faults

DIGITAL SERVO LOOP

Update Time	266 microseconds
Output	12 bit DAC
Servo Tuning	RS232C command interface
Tuning Parameters	PID with digital filter

RS232C Interface

Connections	3-wire connection (Rx, Tx, and GND)
Maximum Daisy Chain	255 units on daisy chain
Address Settings	Via # command
Parameters	9600 baud; 1 stop, 8 data bits; no parity

PROTECTIVE CIRCUITS

Short Circuit	Turns off outputs to motor; latched
Over Temperature	55°C \pm 5°C trip temperature; latched
Overvoltage	95V \pm 5V trip voltage; latched
Undervoltage	21.5V maximum; not latched
Current Foldback	Configurable with 3 resistors

MOTOR CHARACTERISTICS

Minimum Inductance	50 μ H (micro Henrys)
Minimum Resistance	0.25 Ω
Loop Gain Adjustment	Configurable with one resistor

TEMPERATURE

Minimum Temperature	\emptyset °C (32°F)
Maximum Temperature	45°C (113°F) (max. heatplate temp.)
Storage Temperature	-30°C to 85°C (-22°F to 185°F)
Package Dissipation	Heatplate: 0 to 30W, depending on motor current; $P = (I_{AVG}/12 A)30 W$ Cover: 3 watts maximum
Humidity	0 to 95% non condensing
Contaminants	OEM770X is not waterproof, oilproof, or dustproof.

MECHANICAL

Power Connector	10 pin screw terminal 14 AWG (2.5 mm ²) maximum wire size
Input/Output Connector	25 Pin D-connector
Size	5x1.6x3.5 in (127x41x89 mm) approx.
Dimensions	see <i>Chapter 2 Installation</i>
Weight	12 ounces (0.35 kg)

3 Specifications • OEM770X

Motor Specifications: SM160

Parameter	Symbol	Units	SM160A	SM160B
Stall Torque Continuous ¹	T_{cs}	lb-in/oz-in	0.8/13	0.8/13
		N-m	0.09	0.09
Stall Current Continuous ¹	I_{cs} (trap)	Amps DC	2.5	4.8
Rated Speed ²	ω_r	rpm	7500	7500
Peak Torque ⁶	T_{pk}	lb-in/oz-in	2.5/40	2.5/40
		N-m	0.28	0.28
Peak Current ⁶	I_{pk} (trap)	Amps DC	7.4	14.4
Torque @ Rated Speed	T_r	lb-in/oz-in	0.6/10	0.6/10
		N-m	0.07	0.07
Rated Power—Output Shaft	P_o	watts	57	55
Voltage Constant ^{3,4}	K_b	volts/radian/sec	0.038	0.020
Voltage Constant ^{3,4}	K_e	volts/KRPM	4.02	2.08
Torque Constant ^{3,4}	K_t (trap)	oz-in/Amp DC	5.43	2.81
		N-m/Amp DC	0.038	0.020
Resistance ³	R	ohms	3.43	0.90
Inductance ⁵	L	millihenries	0.53	0.13
Thermal Resistance	R_{th} w-a	°C/watt	3.2	3.2
Motor Constant	K_m	oz-in/ \sqrt{watt}	2.93	2.96
		N-m/ \sqrt{watt}	0.021	0.021
Viscous Damping	B	oz-in/Krpm	0.162	0.162
		N-m/Krpm	1.13E-3	1.13E-3
Static Friction	T_f	oz-in	0.10	0.10
		N-m	7.0E-4	7.0E-4
Thermal Time Constant	τ_{th}	minutes	10	10
Electrical Time Constant	τ_e	milliseconds	0.16	0.15
Mechanical Time Constant	τ_m	milliseconds	11.7	11.5
Rotor Inertia	J	lb-in-sec ²	4.4E-5	4.4E-5
		kg-m ²	5.0E-6	5.0E-6
Weight	#	pounds	0.7	0.7
		kg	0.3	0.3
Winding Class			H	H

¹ @ 25°C ambient, 125°C winding temperature, motor connected to a 10"x10"x1/4" aluminum mounting plate, @ 40°C ambient, derate phase currents and torques by 12%.

² Maximum speed is 7500RPM with 500 line encoder. For 1000 line encoders, derate to 6000RPM. For higher speed operation, please call the factory.

³ Measured line-to-line, $\pm 10\%$ line-to-line.

⁴ Value is measured peak of sine wave.

⁵ $\pm 30\%$ line-to-line, inductance bridge measurement @ 1 kHz.

⁶ Initial winding temperature must be 60°C or less before peak current is applied.

Note: These specifications are based on theoretical motor performance and are not specific to any amplifier.

Motor Specifications: SM161 and SM162

Parameter	Symbol	Units	SM161A	SM161B	SM162A	SM162B
Stall Torque Continuous ¹	T_{cs}	lb-in/oz-in	1.6/26	1.6/26	2.9/47	3.1/49
		N-m	0.18	0.18	0.33	0.34
Stall Current Continuous ¹	I_{cs} (trap)	Amps DC	2.3	4.5	2.3	4.4
Rated Speed ²	ω_r	rpm	7,500	7,500	7,500	7,500
Peak Torque ⁶	T_{pk}	lb-in/oz-in	4.9/78	4.9/78	8.8/141	9.1/145
		N-m	0.55	0.54	0.99	1.02
Peak Current ⁶	I_{pk} (trap)	Amps DC	7.0	13.4	6.8	13.2
Torque @ Rated Speed	T_r	lb-in/oz-in	1.1/18	1.1/18	2.3/37	2.3/37
		N-m	0.13	0.13	0.26	0.26
Rated Power—Output Shaft	P_o	watts	97	100	205	204
Voltage Constant ^{3,4}	K_b	volts/radian/sec	0.079	0.041	0.147	0.078
Voltage Constant ^{3,4}	K_e	volts/KRPM	8.27	4.29	15.39	8.17
Torque Constant ^{3,4}	K_t (trap)	oz-in/Amp DC	11.19	5.81	20.82	11.04
		N-m/Amp DC	0.078	0.041	0.146	0.077
Resistance ³	R	ohms	4.53	1.24	6.50	1.73
Inductance ⁵	L	millihenries	0.81	0.21	1.39	0.33
Thermal Resistance	R_{th} w-a	°C/watt	2.70	2.70	2.00	2.00
Motor Constant	Km	oz-in/ \sqrt{watt}	5.26	5.21	8.16	8.40
		N-m/ \sqrt{watt}	0.037	0.036	0.057	0.059
Viscous Damping	B	oz-in/Krpm	0.284	0.284	0.300	0.300
		N-m/Krpm	1.99E-3	1.99E-3	2.1E-3	2.1E-3
Static Friction	T_f	oz-in	0.15	0.15	0.20	0.20
		N-m	1.05E-3	1.05E-3	1.40E-3	1.40E-3
Thermal Time Constant	τ_{th}	minutes	11.6	11.6	14.2	14.2
Electrical Time Constant	τ_e	milliseconds	0.18	0.17	0.21	0.19
Mechanical Time Constant	τ_m	milliseconds	7.7	7.8	5.5	5.2
Rotor Inertia	J	lb-in-sec ²	9.4E-5	9.4E-5	1.6E-4	1.6E-4
		kg-m ²	1.1E-5	1.1E-5	1.8E-5	1.8E-5
Weight	#	pounds	1.1	1.1	1.6	1.6
		kilograms	0.5	0.5	0.7	0.7
Winding Class			H	H	H	H

¹ @ 25°C ambient, 125°C winding temperature, motor connected to a 10"x10"x1/4" aluminum mounting plate, @ 40°C ambient, derate phase currents and torques by 12%.

² Maximum speed is 7500RPM with 500 line encoder. For 1000 line encoders, derate to 6000RPM. For higher speed operation, please call the factory.

³ Measured line-to-line, ±10% line-to-line.

⁴ Value is measured peak of sine wave.

⁵ ±30% line-to-line, inductance bridge measurement @ 1 kHz.

⁶ Initial winding temperature must be 60°C or less before peak current is applied.

Note: These specifications are based on theoretical motor performance and are not specific to any amplifier.

3 Specifications • OEM770X

Motor Specifications: SM230 and SM231

Parameter	Symbol	Units	SM230A	SM230B	SM231A	SM231B
Stall Torque Continuous ¹	T_{cs}	lb-in/oz-in	1.7/27	1.6/26	3.8/61	3.4/54
		N-m	0.19	0.18	0.43	0.38
Stall Current Continuous ¹	I_{cs} (trap)	Amps DC	2.4	4.7	2.5	4.8
Rated Speed ²	ω_r	rpm	7500	7500	7,500	7,500
Peak Torque ⁶	T_{pk}	lb-in/oz-in	5.1/82	4.9/78	11.3/181	10.0/160
		N-m	0.57	0.55	1.27	1.12
Peak Current ⁶	I_{pk} (trap)	Amps DC	7.1	14.2	7.6	14.3
Torque @ Rated Speed	T_r	lb-in/oz-in	1.4/22	1.3/21	2.9/47	2.8/44
		N-m	0.15	0.15	0.33	0.31
Rated Power—Output Shaft	P_o	watts	122	116	261	244
Voltage Constant ^{3,4}	K_b	volts/radian/sec	0.081	0.039	0.169	0.079
Voltage Constant ^{3,4}	K_e	volts/KRPM	8.48	4.09	17.70	8.27
Torque Constant ^{3,4}	K_t (trap)	oz-in/Amps DC	11.47	5.54	23.93	11.19
		N-m/Amps DC	0.080	0.039	0.168	0.078
Resistance ³	R	ohms	4.43	1.12	5.22	1.46
Inductance ⁵	L	millihenries	1.19	0.28	1.64	0.44
Thermal Resistance	R_{th} w-a	°C/watt	2.67	2.67	2.00	2.00
Motor Constant	Km	oz-in/ \sqrt{watt}	5.45	5.23	10.47	9.26
		N-m/ \sqrt{watt}	0.038	0.037	0.073	0.065
Viscous Damping	B	oz-in/Krpm	0.160	0.160	0.250	0.250
		N-m/Krpm	1.12E-3	1.12E-3	1.75E-3	1.75E-3
Static Friction	T_f	oz-in	0.20	0.20	0.30	0.30
		N-m	1.4E-3	1.4E-3	2.10E-3	2.10E-3
Thermal Time Constant	τ_{th}	minutes	18.3	18.3	20	20
Electrical Time Constant	τ_e	milliseconds	0.27	0.25	0.31	0.30
Mechanical Time Constant	τ_m	milliseconds	18.3	19.9	9.5	12.2
Rotor Inertia	J	lb-in-sec ²	2.4E-4	2.4E-4	4.6E-4	4.6E-4
		kg-m ²	2.7E-5	2.7E-5	5.2E-5	5.2E-5
Weight	#	pounds	1.2	1.2	2.1	2.1
		kg	0.5	0.5	1.0	1.0
Winding Class			H	H	H	H

¹ @ 25°C ambient, 125°C winding temperature, motor connected to a 10"x10"x1/4" aluminum mounting plate, @ 40°C ambient derate phase currents and torques by 12%.

² Maximum speed is 7500RPM with 500 line encoder. For 1000 line encoders, derate to 6000RPM. For higher speed operation, please call the factory.

³ Measure line-to-line, $\pm 10\%$ line-to-line.

⁴ Value is measured peak of sine wave.

⁵ $\pm 30\%$, line-to-line, inductance bridge measurement @ 1 kHz.

⁶ Initial winding temperature must be 60°C or less before peak current is applied.

Note: These specifications are based on theoretical motor performance and are not specific to any amplifier.

Motor Specifications: SM232 and SM233

Parameter	Symbol	Units	SM232A	SM232B	SM233A	SM233B
Stall Torque Continuous ¹	T_{cs}	lb-in/oz-in	6.6/106	7.0/111	10.1/161	9.7/156
		N-m	0.74	0.78	1.13	1.09
Stall Current Continuous ¹	I_{cs} (trap)	Amps DC	2.4	4.7	2.4	4.5
Rated Speed ²	ω_r	rpm	7,500	7,500	5,800	5,800
Peak Torque ⁶	T_{pk}	lb-in/oz-in	19.8/316	20.9/334	30.2/483	29.2/467
		N-m	2.21	2.34	3.38	3.27
Peak Current ⁶	I_{pk} (trap)	Amps DC	7.2	14.0	7.1	13.6
Torque @ Rated Speed	T_r	lb-in/oz-in	5.1/81	5.4/86	8.1/129	7.6/121
		N-m	0.57	0.60	0.90	0.85
Rated Power—Output Shaft	P_o	watts	449	477	553	519
Voltage Constant ^{3,4}	K_b	volts/radian/sec	0.310	0.169	0.484	0.242
Voltage Constant ^{3,4}	K_e	volts/KRPM	32.46	17.70	50.68	25.34
Torque Constant ^{3,4}	K_t (trap)	oz-in/Amp DC	43.90	23.93	68.53	34.27
		N-m/Amp DCs	0.307	0.168	0.480	0.240
Resistance ³	R	ohms	7.50	2.00	9.65	2.58
Inductance ⁵	L	millihenries	2.90	0.78	4.08	1.06
Thermal Resistance	R_{th} w-a	°C/watt	1.54	1.54	1.25	1.25
Motor Constant	Km	oz-in/ \sqrt{watt}	16.03	16.92	22.06	21.33
		N-m/ \sqrt{watt}	0.112	0.118	0.154	0.149
Viscous Damping	B	oz-in/Krpm	0.360	0.360	0.540	0.540
		N-m/Krpm	2.52E-3	2.52E-3	3.78E-3	3.78E-3
Static Friction	T_f	oz-in	0.70	0.70	1.00	1.00
		N-m	4.90E-3	4.90E-3	7.00E-3	7.00E-3
Thermal Time Constant	τ_{th}	minutes	21.6	21.6	23.3	23.3
Electrical Time Constant	τ_e	milliseconds	0.39	0.39	0.42	0.41
Mechanical Time Constant	τ_m	milliseconds	7.2	6.5	5.4	5.8
Rotor Inertia	J	lb-in-sec ²	8.2E-4	8.2E-4	1.2E-3	1.2E-3
		kg-m ²	9.3E-5	9.3E-5	1.3E-4	1.3E-4
Weight	#	pounds	3.0	3.0	3.9	3.9
		kilograms	1.4	1.4	1.8	1.8
Winding Class			H	H	H	H

¹ @ 25°C ambient, 125°C winding temperature, motor connected to a 10"x10"x1/4" aluminum mounting plate, @ 40°C ambient, derate phase currents and torques by 12%.

² Maximum speed is 7500RPM with 500 line encoder. For 1000 line encoders, derate to 6000RPM. For higher speed operation, please contact factory.

³ Measured line-to-line, $\pm 10\%$ line-to-line.

⁴ Value is measured peak of sine wave.

⁵ $\pm 30\%$, line-to-line, inductance bridge measurement @ 1 kHz.

⁶ Initial winding temperature must be 60°C or less before peak current is applied.

Note: These specifications are based on theoretical motor performance and are not specific to any amplifier.

3 Specifications • OEM770X

Motor Specifications: NeoMetric & J Series

Parameter	Symbol	Units	N0701 or N0341		N0702 or N0342	
			D	F	E	F
Winding Selection						
Stall Torque Continuous ¹	T_{cs}	lb-in N-m	5.7 0.63	5.6 0.63	10.4 1.17	10.4 1.16
Stall Current Continuous ¹	I_{cs} (trap)	Amps DC	2.9	4.5	3.3	4.6
Rated Speed ²	ω_r	rpm	7500	7500	7500	7500
Peak Torque ⁶	T_{pk}	lb-in N-m	17.0 1.90	16.8 1.88	31.2 3.50	31.1 3.49
Peak Current ⁶	I_{pk} (trap)	Amps DC	8.7	13.5	10.0	13.9
Torque @ Rated Speed	T_r	lb-in N-m	4.7 0.53	4.6 0.52	7.1 0.80	7.9 0.88
Rated Power—Output Shaft	P_o	watts	416	411	632	699
Voltage Constant ^{3,4}	K_b	volts/radian/sec	0.221	0.140	0.353	0.253
Voltage Constant ^{3,4}	K_e	volts/KRPM	23.14	14.66	36.97	26.49
Torque Constant ^{3,4}	K_t (trap)	oz-in/Amp DC N-m/Amp DC	31.29 0.219	19.82 0.139	49.98 0.350	35.82 0.251
Resistance ³	R	ohms	5.52	2.27	5.22	2.70
Inductance ⁵	L	millihenries	12.98	5.23	15.80	8.16
Thermal Resistance	R_{th} w-a	°C/watt	1.44	1.44	1.15	1.15
Motor Constant	Km	oz-in/ \sqrt{watt} N-m/ \sqrt{watt}	13.32 0.093	13.16 0.092	21.88 0.153	21.80 0.153
Viscous Damping	B	oz-in/Krpm N-m/Krpm	0.2 1.4E-3	0.2 1.4E-3	0.4 2.8E-3	0.4 2.8E-3
Static Friction	T_f	oz-in N-m	0.8 5.6E-3	0.8 5.6E-3	1.6 1.2E-2	1.6 1.2E-2
Thermal Time Constant	τ_{th}	minutes	16.6	16.6	21.7	21.7
Electrical Time Constant	τ_e	milliseconds	2.35	2.30	3.03	3.02
NeoMetric Mech. Time Const.	τ_{mch}	milliseconds	1.6	1.7	0.6	0.6
J Series Mech. Time Const.	τ_{mch}	milliseconds	14.7	14.7	5.7	5.7
NeoMetric Rotor Inertia	J	lb-in-sec ² kg-m ²	1.1E-4 1.2E-5	1.1E-4 1.2E-5	1.7E-4 2.0E-5	1.7E-4 2.0E-5
J Series Rotor Inertia	J	lb-in-sec ² kg-m ²	1.1E-3 1.3E-4	1.1E-3 1.3E-4	1.2E-3 1.4E-4	1.2E-3 1.4E-4
NeoMetric Weight	# kg	pounds kilograms	3.5 1.6	3.5 1.6	4.5 2.1	4.5 2.1
J Series Weight	# kg	pounds kilograms	4.4 2.0	4.4 2.0	5.4 2.5	5.4 2.5
Winding Class				H		H

@ 25°C ambient, 125°C winding temperature, motor connected to a 10"x10"x1/4" aluminum mounting plate, @ 40°C ambient, derate phase currents and torques by 12%.

² Maximum speed is 7500RPM with 500 line encoder. For 1000 line encoders, derate to 6000RPM. For higher speed operation, please contact factory.

³ Measured line-to-line, ±10% line-to-line.

⁴ Value is measured peak of sine wave.

⁵ ±30%, line-to-line, inductance bridge measurement @ 1 kHz.

⁶ Initial winding temperature must be 60°C or less before peak current is applied.

Note: These specifications are based on theoretical motor performance and are not specific to any amplifier.

Speed/Torque Curves²: SM 160, SM161 and SM162

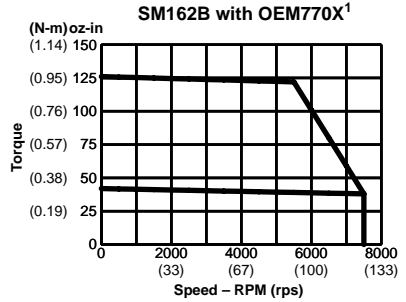
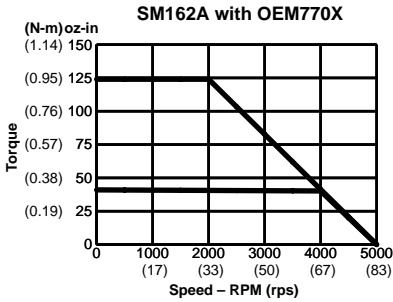
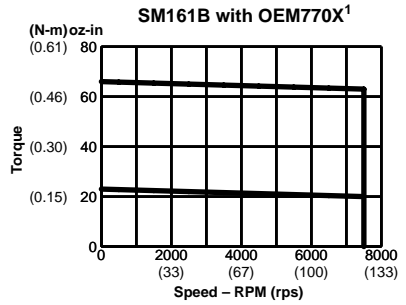
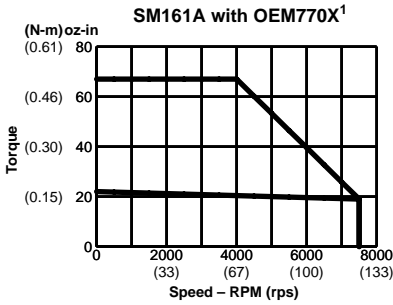
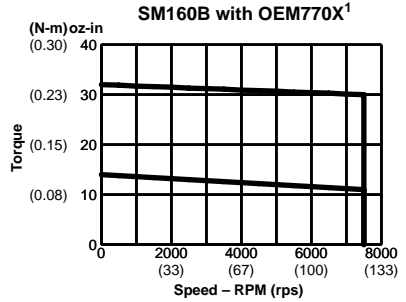
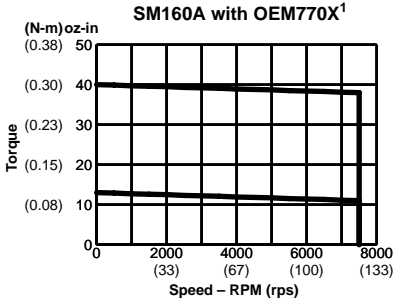

¹ For "E" encoder option (1000 ppr), maximum velocity is 6,000 rpm (100 rps).

² With 75VDC bus voltage; 25°C (77°F) ambient temperature.

3 Specifications • OEM770X

Speed/Torque Curves²: SM230, SM231, SM232, SM233

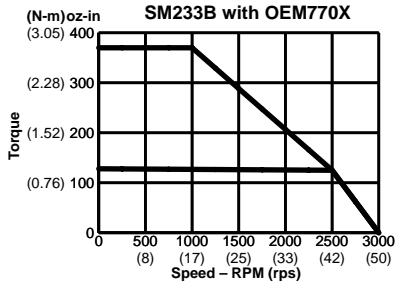
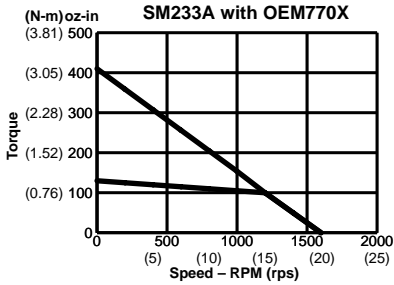
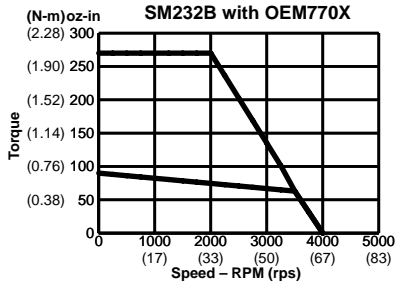
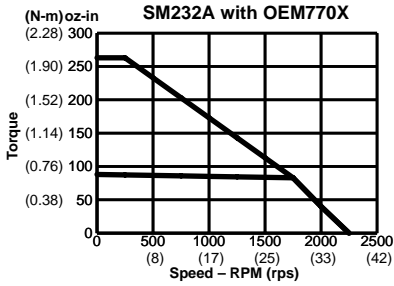
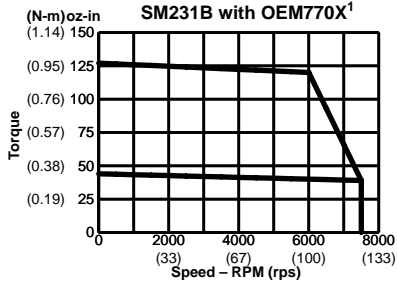
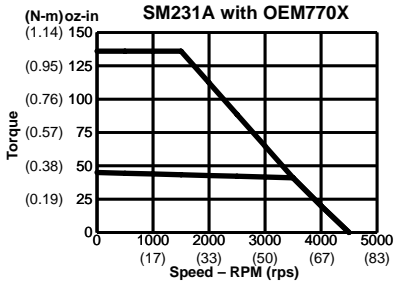
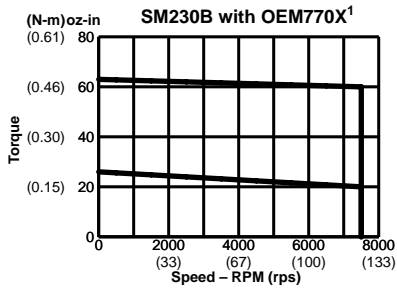
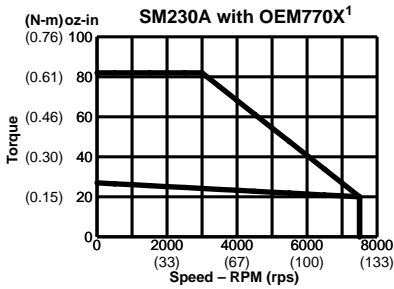

¹ For "E" encoder option (1000 ppr), maximum velocity is 6,000 rpm (100 rps).

² With 75VDC bus voltage; 25°C (77°F) ambient temperature.

Speed/Torque Curves¹: NeoMetric & J Series Motors

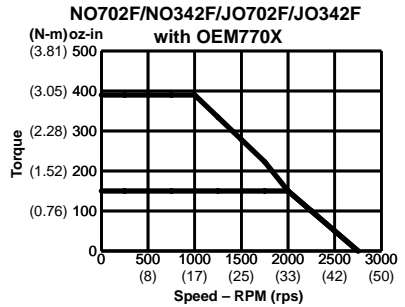
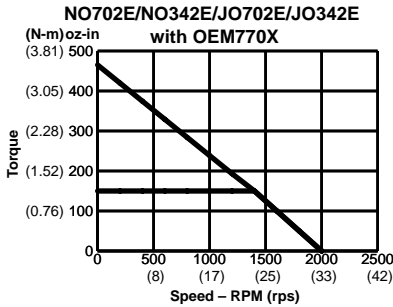
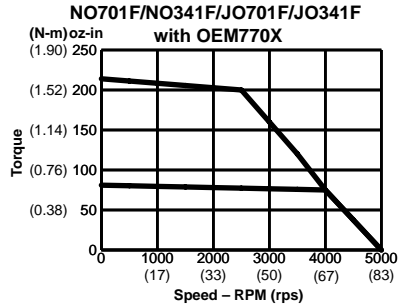
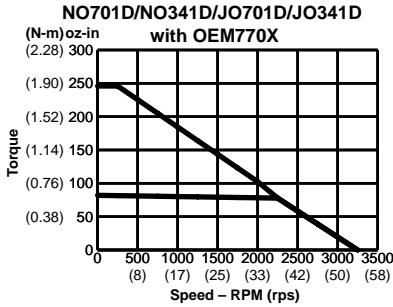

¹ With 75VDC bus voltage; 25°C (77°F) ambient temperature.

Motor Dimensions: Compumotor SM160 and SM230

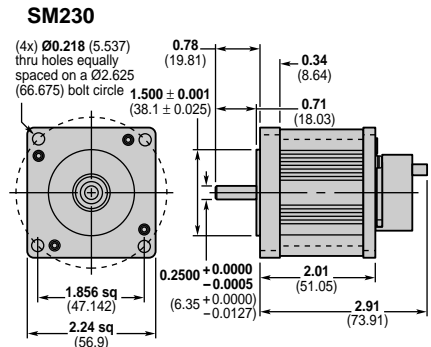
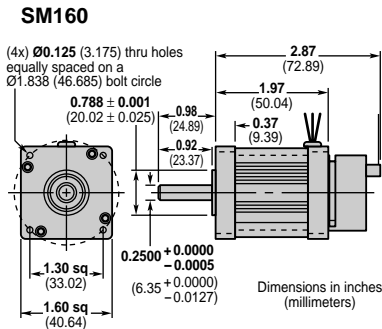

3 Specifications • OEM770X

Motor Dimensions: Compumotor SM Series, Size 16

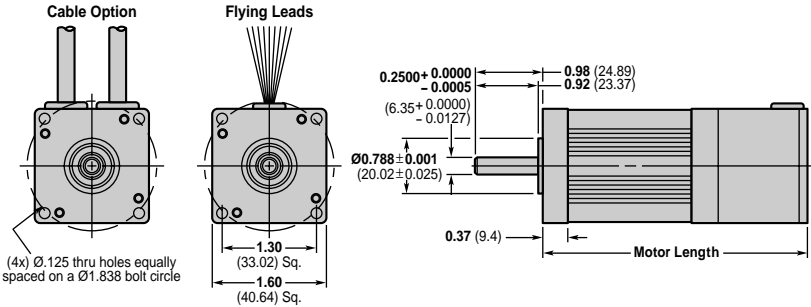

Cable Options	
Part #	Description
- FL	18" Flying Leads
- 10	10 ft. Cable

Longer lengths available
Consult Compumotor for information

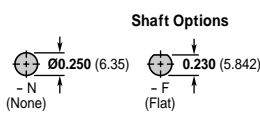

Dimensions in inches (millimeters)

Motor Sizes	
Motor Length	Model
4.79 (121.66)	162 Motor
3.79 (96.27)	161 Motor

Motor Dimensions: Compumotor SM Series, Size 23

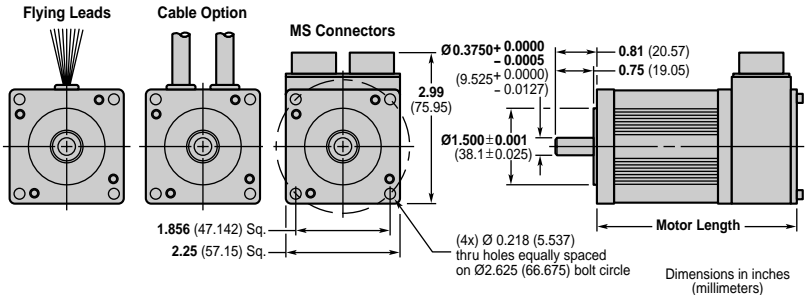

Cable Options	
Part #	Description
- FL	18" Flying Leads
- 10	10 ft. Cable

Longer lengths available
Consult Compumotor for information

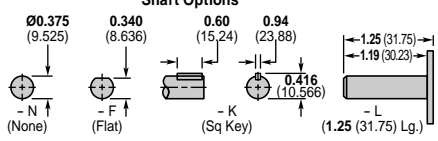

Dimensions in inches (millimeters)

Motor Sizes	
Motor Length	Model
5.98 (151.89)	233 Motor
4.98 (126.49)	232 Motor
3.98 (101.09)	231 Motor

Motor Dimensions: NeoMetric & J Series, Size 70

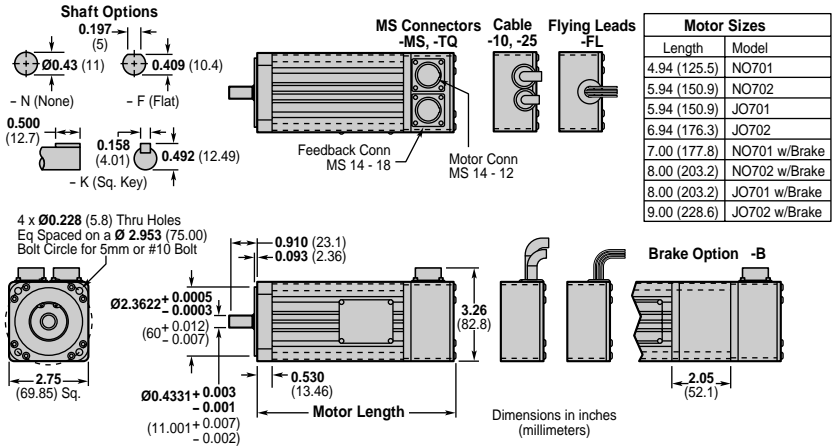

Motor Dimensions: NeoMetric & J Series, Size 34

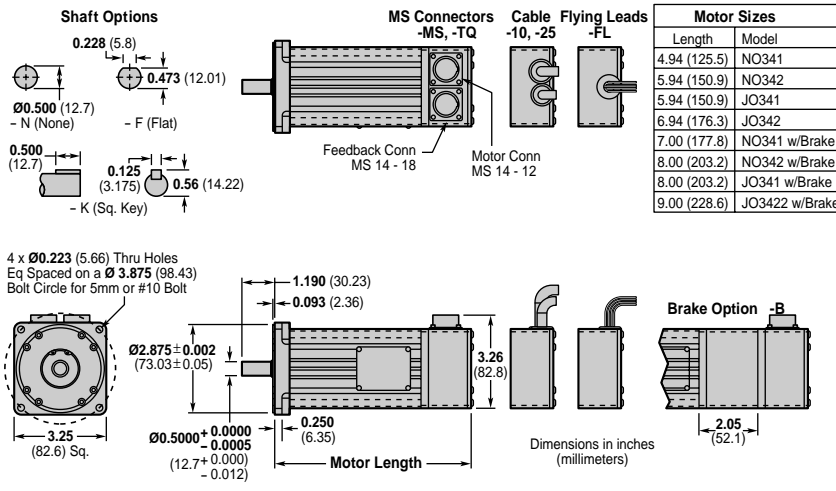

3 Specifications • OEM770X

Encoder Specifications

The same type of encoder is used on all SM and NeoMetric Series motors. Encoders have either 500 lines ("-D") or 1000 lines ("-E").

Mechanical

Accuracy ± 2 min of arc

Electrical

Input power 5 VDC $\pm 5\%$, 135 mA

Operating frequency 100 kHz max

Output device 26LS31

Sink/Source, nominal 20 mA

Suggested user interface 26LS32

Hall Effect Specifications

Specifications for Hall effect outputs on SM and NeoMetric Series motors are listed below.

Electrical

Input power 5 VDC $\pm 5\%$, 80 mA

Output device, open collector LM339

Maximum pull up 12 VDC

Sink 16 mA

COMMUTATION CHART

This chart shows the relationship between motor back EMF and Hall state.

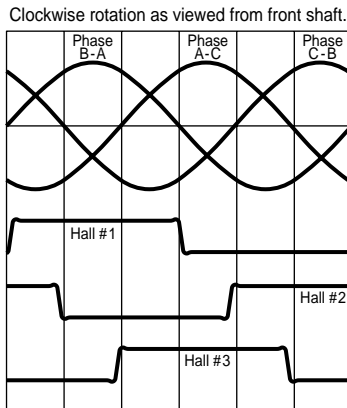

Motor Wiring Information

SM MOTORS – SIZE 16 AND SIZE 23

Motor Phase

Designation	-MS Option	-TQ Option	-H Option	-FL Option -10 Option -25 Option
	Pin No. MS14-12	Pin No. MS14-12	Pin No. MS14-12	Wire Color
Phase A	J	J	J	Red/Yellow
Phase B	K	K	K	White/Yellow
Phase C	L	L	L	Black/Yellow
Ground	M	M	M	Green/Yellow
Shield	NC	NC	NC	—
Temp	G	G	G	Orange/Yellow or Yellow
Temp	H	H	H	Orange/Yellow or Yellow

Encoder

Designation	Pin No. MS14-18	Pin No. MS14-18	Not Applicable	Wire Color
Vcc	H	H	—	Red
Ground	G	G	—	Black
CH A+	A	A	—	White
CH A-	B	B	—	Yellow
CH B+	C	C	—	Green
CH B-	D	D	—	Blue
Index +	E	E	—	Orange
Index -	F	F	—	Brown
Shield	NC	NC	—	—

Hall-effect

Designation	Pin No. MS14-18	Pin No. MS14-12	Pin No. MS14-12	Wire Color
Hall GND	K	F	F	White/Green
Hall +5	M	B	B	White/Blue
Hall 1	T	C	C	White/Brown
Hall 2	U	D	D	White/Orange
Hall 3	P	E	E	White/Violet

Wiring color is provided for flying lead or cable versions.

3 Specifications • OEM770X

NEOMETRIC & J SERIES MOTORS – SIZE 070 (SIZE 034)

Motor Phase

Designation	Pin No. MS14-12	Wire Color
Phase A	J	Red/Yellow
Phase B	K	White/Yellow
Phase C	L	Black/Yellow
Ground	M	Green/Yellow
Shield	NC	—

Continue for “H” or “TQ” Options

Temp	G	Orange/Yellow or Yellow
Temp	H	Orange/Yellow or Yellow
Hall GND	F	White/Green
Hall +5	B	White/Blue
Hall 1	C	White/Brown
Hall 2	D	White/Orange
Hall 3	E	White/Violet

Encoder/Commutation Connections

Designation	Pin No. MS14-18	Wire Color
Encoder		
+5 VDC	H	Red
Ground	G	Black
CH A+	A	White
CH A-	B	Yellow
CH B+	C	Green
CH B-	D	Blue
Index +	E	Orange
Index -	F	Brown
Commutation		
Hall GND	K	White/Green
Hall +5	M	White/Blue
Hall 1	T	White/Brown
Hall 2	U	White/Orange
Hall 3	P	White/Violet
Temp	L	Orange/Yellow or Yellow
Temp	N	Orange/Yellow or Yellow
Brake Option		
Brake ¹	R	Red/Blue
Brake ¹	S	Red/Blue

¹ Brake will operate regardless of polarity of connection.