

Connections see also pages 7-19

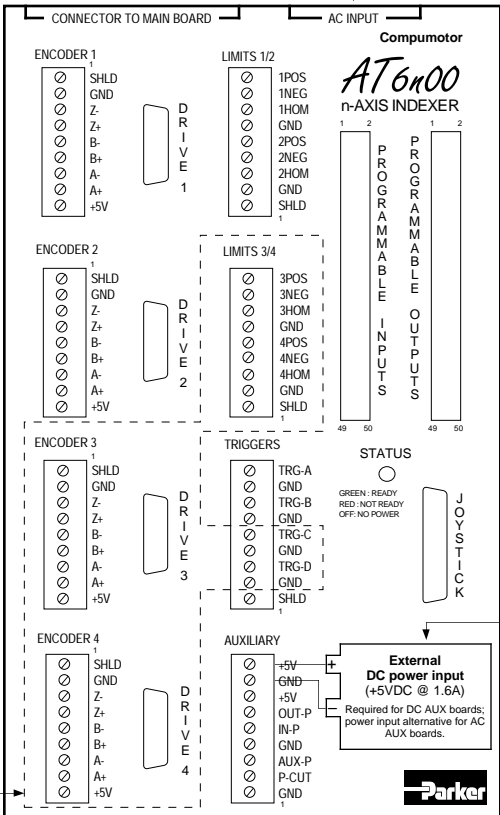

Dashed line denotes features not available on the AT6200.

PIN OUTS FOR "D" CONNECTORS

PROGRAMMABLE INPUTS & OUTPUTS

Pin	Function
49	+5VDC
47	Input or Output #1 (LSB)
45	Input or Output #2
43	Input or Output #3
41	Input or Output #4
39	Input or Output #5
37	Input or Output #6
35	Input or Output #7
33	Input or Output #8
31	Input or Output #9
29	Input or Output #10
27	Input or Output #11
25	Input or Output #12
23	Input or Output #13
21	Input or Output #14
19	Input or Output #15
17	Input or Output #16
15	Input or Output #17
13	Input or Output #18
11	Input or Output #19
9	Input or Output #20
7	Input or Output #21
5	Input or Output #22
3	Input or Output #23
1	Input or Output #24 (MSB)

Even numbered pins are connected to logic ground.

DRIVE

Pin	Function
1	Step +
2	Direction +
4	In-Position
5	Drive Fault
7	+5VDC Output
8	Shield (chassis gnd)
9	Step Return (-)
10	Direction Return (-)
11	Shutdown +
12	Shutdown Return (-)
13	Isolated Logic gnd
14	Isolated Logic gnd

Pins 3, 6, & 15 are reserved

JOYSTICK

Pin	Function
1-4	Analog Channels 1-4
8	Shield (chassis gnd)
14	Isolated Logic gnd
15	Axes Select Input
16	Velocity Select Input
17	Release Input
18	Trigger Input
19	Auxiliary Input
23	+5VDC Output

Pins 5-7, 9-13, 20-21, 24-25 are reserved

I/O SPECIFICATIONS AND INTERNAL SCHEMATICS

Power Input:
 AT6200 AC AUX Board.....90-264VAC, 50/60 Hz, 0.3A @ 240VAC, single-phase.
 AT6400 120V AUX Board.....90-132VAC, 50/60 Hz, 1.5A @ 120VAC, single-phase.
 AT6400 240V AUX Board.....90-264VAC, 50/60 Hz, 0.3A @ 240VAC, single-phase.
 AT6n00 DC AUX Board.....+5VDC (±5%) @ 1.6A (connect to the AUXILIARY connector).

Internal Schematics

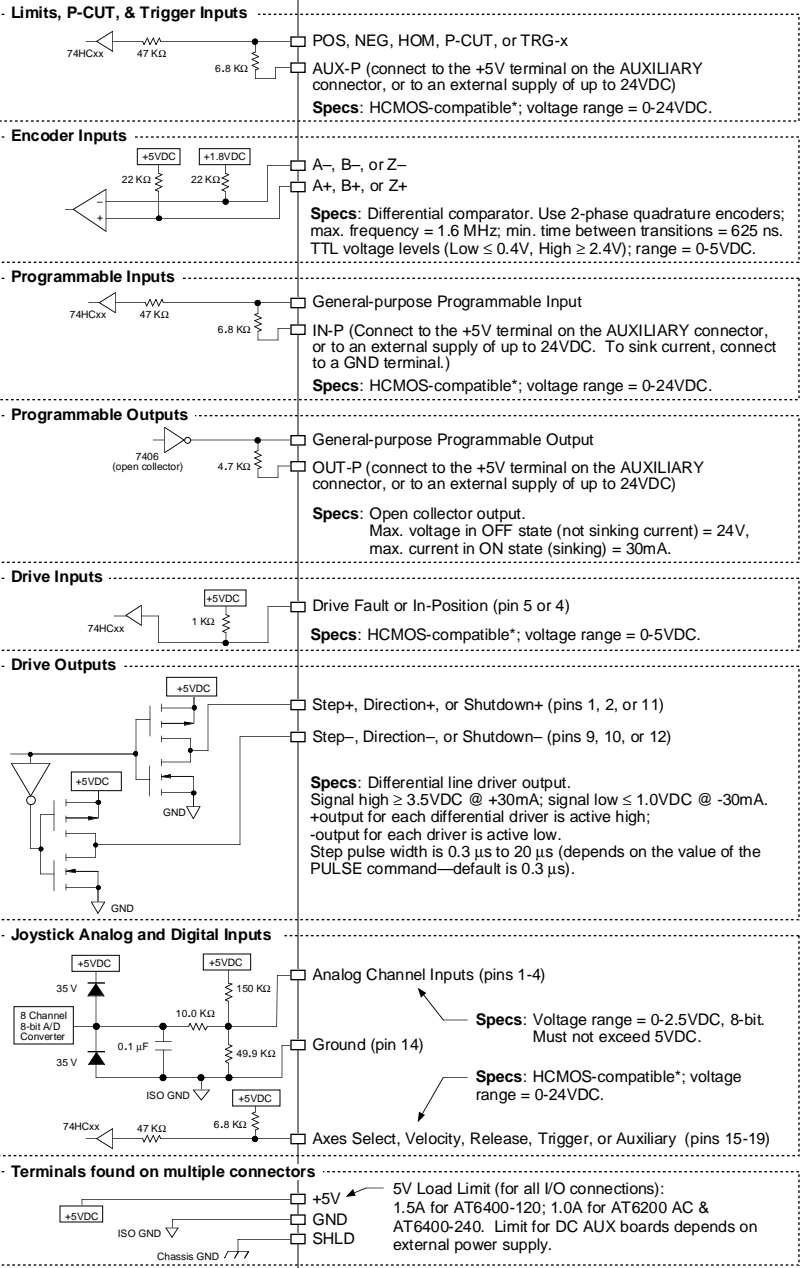

* HCMOS-compatible levels: Low ≤ 1.00V, High ≥ 3.25V.

Troubleshooting see also pages 24-28

- LEDs – see illustration (right).
- Status information (see command descriptions in *6000 Series Software Reference Guide*):
 - Axis status (general problem conditions)...TAS command
 - Joystick analog voltage.....TANV command
 - Joystick digital inputs.....TINO command (bits 1-5)
 - Limit switches.....TLIM command
 - P-CUT input.....TINO command (bit 6)
 - Programmable and trigger inputs.....TIN command
 - Programmable outputs.....TOUT command
- P-CUT input terminal must be grounded to GND terminal to allow motion.
- Programmable input functions (INFNC command) and drive fault detection will not be operable until you enable input functions with the INFEN1 command.
- Incorrect drive fault level (DRFLVL command) will prevent motion.
- To help prevent electrical noise, shield all connections at one end only.
- Error messages while programming or executing programs – see the *6000 Series Programmer's Guide*.
- Download errors – see page 27.
- Address, transfer mode, and interrupt DIP switch settings – see page 4.
- Technical support – see phone numbers on inside of front cover.

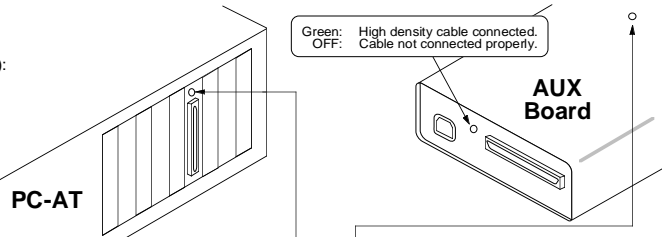

After applying power, the status LED on the AT6n00 PC card will be off and the status LED on the AUX board should be red. If the LED on the AUX board is off, the AUX board does not have AC power.

After downloading the operating system, the status LEDs on the AUX board and the PC card will turn green indicating the system is ready for operation. If both status LEDs do not turn green after downloading the operating system, an error has occurred. The download program (AT6400) issues an error message if it cannot find the card or if the download operation is not successful (refer also to the troubleshooting information in Chapter 2, Troubleshooting).

Board Monitor Alarm (BMA): Detects un-recoverable faults in hardware and software. When the BMA detects fault, the status LED on AT6n00 PC card turns off. The BMA can be reset by cycling power to the PC-AT, or by re-downloading the AT6n00 operating system.