

Appendix D

LVD Installation Instructions

For more information about LVD, see 73/23/EEC and 93/68/EEC, published by the European Economic Community (EEC).

Environmental Conditions

Pollution Degree

APEX615n Controller/Drives are designed for pollution degree 2.

Installation Category

APEX615n Controller/Drives are designed for installation category II.

Electrical

Connecting and Disconnecting Power Mains

The APEX615n Controller/Drive's protective earth connection is provided through its power mains connector. You must reliably earth the APEX615n Controller/Drive's protective earth connection.

Attach or remove the APEX615n Controller/Drive's power plug only while input power is OFF.

Using an Isolation Transformer

The APEX615n Controller/Drive's mains voltage is limited to 240 VAC nominal. If your mains voltage is higher, use an isolation transformer located between the power mains and the APEX615n Controller/Drive. Your isolation transformer should be insulated to ~2300V rms.

Do not interrupt the protective earth conductor between the source mains and the isolation transformer's secondary. The core of the isolation transformer and the drive's protective conductor terminal must *both* be connected to the main's protective earth conductor.

CAUTION

Do not use an autotransformer.

Line Fuses

Line fuses need to be added to protect the transformer and associated wiring. If the live wire cannot be readily identified, fuse both phase conductors. The value of fuse required is given by:

$$(1.5 \times VA)/(\text{supply volts}) \quad [\text{amps}]$$

Fuse types should be anti-surge HBC.



Connecting the Protective Conductor Terminal to Earth

You must provide a connection from the APEX615n Controller/Drive's protective conductor terminal to the protective earth conductor of the mains. This connection is *in addition* to the protective earth connection provided through the APEX615n Controller/Drive's mains connector.

The protective conductor terminal is marked with a label on the product bearing the following symbol:



Protective Conductor Terminal Marking

To connect the protective conductor terminal to earth, complete these steps:

- 1 Use a spade lug in combination with a star washer to make good contact with the bare metal surface of the APEX615n Controller/Drive.
- 2 Use a green and yellow wire to reliably earth the protective conductor terminal. Wire gauge must be no thinner than the current-carrying wire in the product's mains supply.
- 3 Resistance between the protective conductor terminal and earth must be no greater than 0.1 W. Use thicker gauge wire if the resistance is too high.

Providing a Protective Earth Connection for Motors

You must provide a connection from the APEX motor to a reliable earth system. This connection provides a protective earth for the motor, and is *in addition* to the earth connection provided by the earth wire in the motor's power cable. The motor's protective earth connection is important for safety reasons, and *must not be omitted*.

Make connections according to the following instructions and diagram:

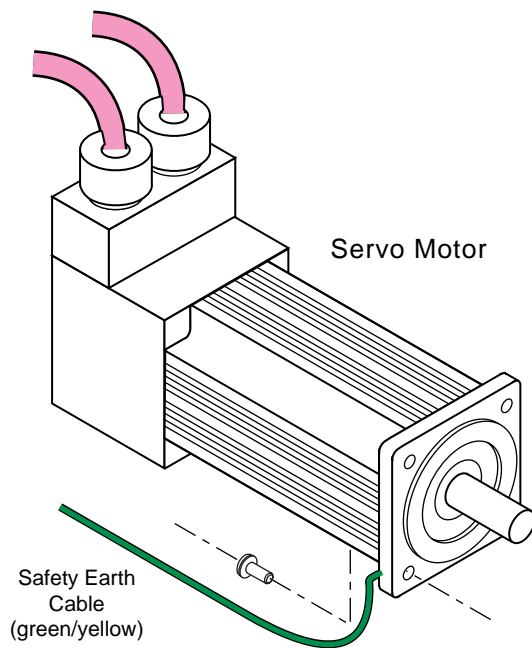

Providing Protective Earth Connection for Motor

- 1 Use a spade lug in combination with a star washer and mounting bolt to make good contact with the bare metal surface of the motor's mounting flange.
- 2 Use a green and yellow striped wire to make the connection between the motor and earth. Wire gauge must be no thinner than the current carrying wire in the motor's power cable.
- 3 Resistance between the motor and earth must be no greater than 0.1 W. Use thicker gauge wire if the resistance is too high.

Mechanical

Installing in an Enclosure

The APEX615n Controller/Drive must be installed within an enclosure. The enclosure's interior must not be accessible to the machine operator. The enclosure should be opened only by skilled or trained service personnel.

Servicing the APEX Drive







Changing Firmware	Only skilled or trained personnel should change firmware.
Changing Batteries	The APEX615n Controller/Drive contains a replaceable lithium battery, of type Duracell DL2450, or Sanyo CR2450, or equivalent. Only skilled or trained personnel should change batteries.
Disposal of Batteries	Dispose of batteries in accordance with local regulations.
Do Not Replace Fuses	The APEX 615n Controller/Drive has no fuses designed to be replaced by the user. Fuse failure indicates that other components have also failed. Fuses and other components should only be replaced by Compumotor or its designated repair facilities.

Thermal Safety

The Motor May Be Hot	The motor may reach high temperatures during normal operations, and may remain hot after power is removed.
----------------------	--

Table of Graphic Symbols and Warnings

The following symbols may appear in this user guide, and may be affixed to the products discussed in this user guide.

Symbol	Description
	Earth Terminal
	Protective Conductor Terminal
	Frame or Chassis Terminal
	Equipotentiality
	Caution, Risk of Electric Shock
	Caution, Refer to Accompanying Text
	Hot Surface