

CHAPTER FOUR

Hardware Reference

IN THIS CHAPTER

- APEX Drive Specifications
 - Input/Output Pinouts and Circuit Diagrams
 - Motor Specifications, Speed/Torque curves, and Dimensions
-

APEX DRIVE GENERAL SPECIFICATIONS

INPUT POWER – L1/L2/(L3)

	APEX10	APEX20	APEX40
Voltage Range	85-252VAC (1-phase)	85 – 252VAC (1- or 3-phase)	85 – 252VAC (1- or 3-phase)
Frequency Range	47-66 Hz	47-66 Hz	47-66 Hz
Current (max. continuous)	14A (rms) at 120VAC 1-ph; 10A (rms) at 240VAC 1-ph;	8A (rms) 3-ph	15A (rms) 3-ph
Power (max. continuous)	2.4 KVA	3.3 KVA	6.2 KVA
Fuses	No internal fuses. Recommended external fuse: see <i>Chapter 2 Installation.</i>		
Isolation Transformer	Not required	Not required	Not required

Actual input power and current is a function of the motor's operating point (speed and torque) and the duty cycle. The numbers above reflect the servo motor and drive operating at rated speed and rated torque at 100% duty.

INPUT POWER – CONTROL L1/CONTROL L2

	All APEX Drives
Voltage Range	85-252VAC (1-phase)
Frequency Range	47-66 Hz
Current (max. continuous)	1 amp
Power (max. continuous)	0.08 KVA
Fuses	3.0A 250VAC internal fuse. Not user replaceable.
Isolation Transformer	Not required

OUTPUT POWER

		APEX10	APEX20	APEX40
Voltage	(nominal)	170 or 340VDC	340VDC	340VDC
	(maximum)	420VDC	420VDC	420VDC
Frequency	(fundamental)	0 – 400 Hz	0 – 400 Hz	0 – 400 Hz
		15 KHz PWM	8 KHz PWM	8 KHz PWM
Current	continuous (per phase)	8A sinusoidal	12A sinusoidal	20A sinusoidal
		5.66A rms	8.50A rms	14.14A rms
	peak (per phase)	16A sinusoidal	24A sinusoidal	40A sinusoidal
		11.31A rms	17.0A rms	28.3A rms

I/O PINOUTS & CIRCUIT DRAWINGS

This section is organized by connector. Pin outs and circuit drawings for all APEX Drive input and output connectors are shown in this section.

AC INPUT CONNECTOR; MOTOR CONNECTOR (DC OUTPUT CONNECTOR)

For illustration, the APEX10 Drive is shown below. The other APEX Drives are similar.

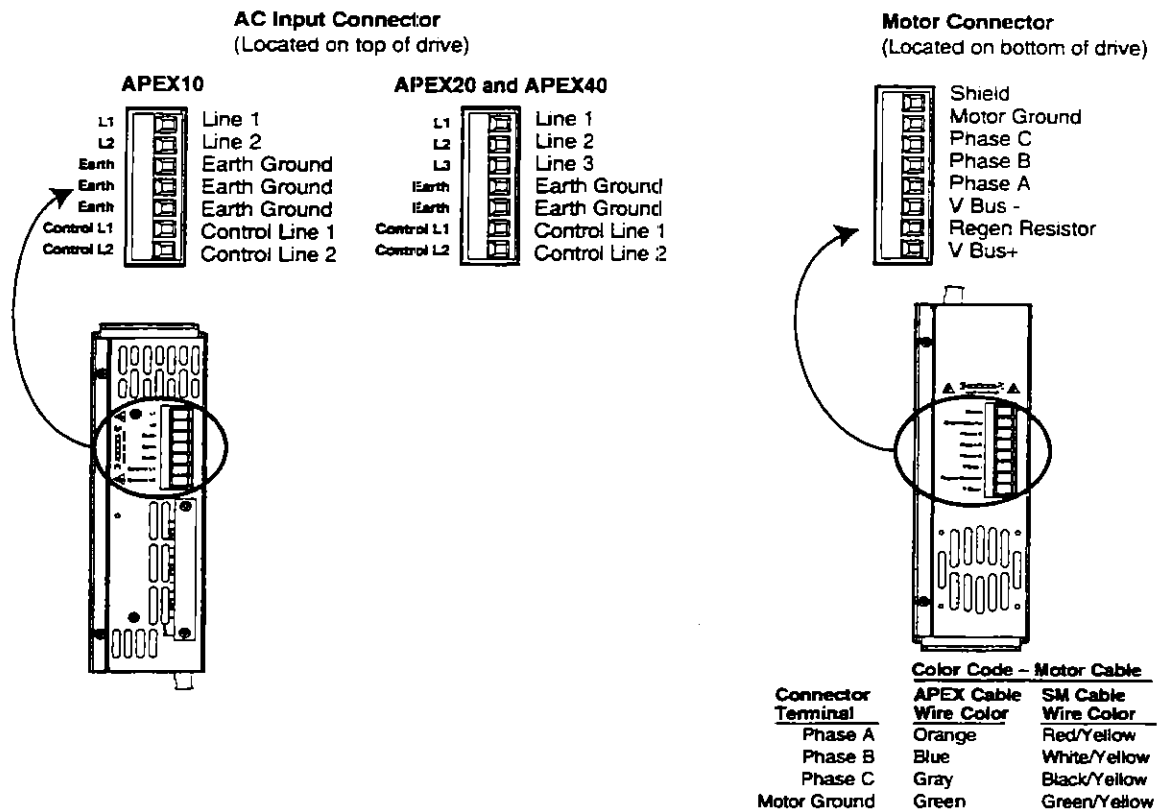

Mating Connector:
7 pin removable connector
Compumotor P/N 43-013575-01

Mating Connector:
8 pin removable connector
Compumotor P/N 43-014533-01

GROUNDING

Motor Ground and **Shield** (on the motor connector) are connected together internally, and are also connected internally to **Earth** on the AC Input connector, and to the chassis.

CONTROLLER CONNECTOR

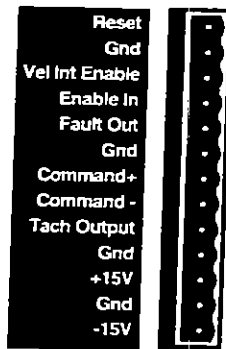

Controller Connector

Pin #:	Function:
1	Reset
2	Ground
3	Velocity Integrator Enable
4	Enable In
5	Fault Output
6	Ground
7	Command+
8	Command-
9	Tachometer Output
10	Ground
11	+15V
12	Ground
13	-15V

Mating Connector:
 13 pin screw terminal
 removable connector
 Compumotor P/N 43-013802-01

Schematic diagrams of each input and output on the controller connector are shown below.

RESET INPUT

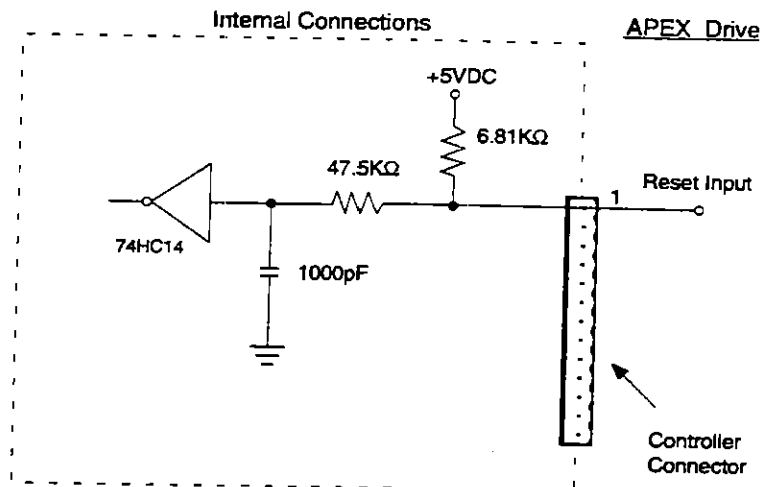

- Active Low:** to reset drive, hold reset input at low voltage for at least 20 milliseconds.
- Voltage Low** = 1.0V maximum
- Voltage High** = 3.25V - 5.0V
- Reset will begin when input reset signal (a low voltage) is released.

VELOCITY INTEGRATOR ENABLE

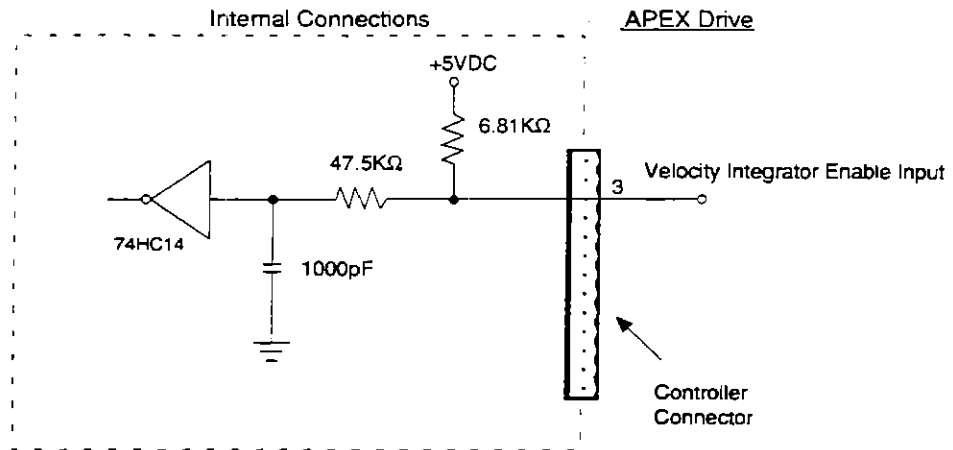

- Active Low:** to enable the velocity integrator, hold input at low voltage
- Voltage Low** = 1.0V maximum
- Voltage High** = 3.25V - 5.0V
- DIP Switch #3, Position 1, must be ON**

ENABLE INPUT

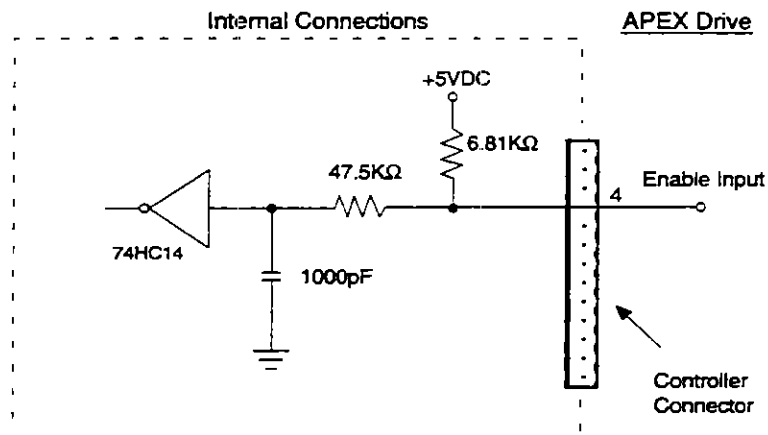

- Active Low:** to enable the APEX Drive, hold Enable Input at low voltage
- Voltage Low** = 1.0V maximum
- Voltage High** = 3.25V - 5.0V

FAULT OUTPUT

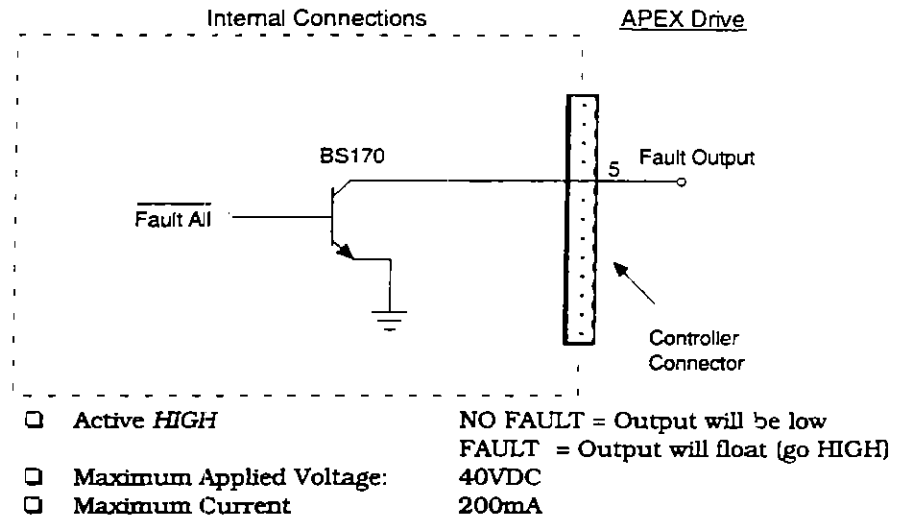

COMMAND±

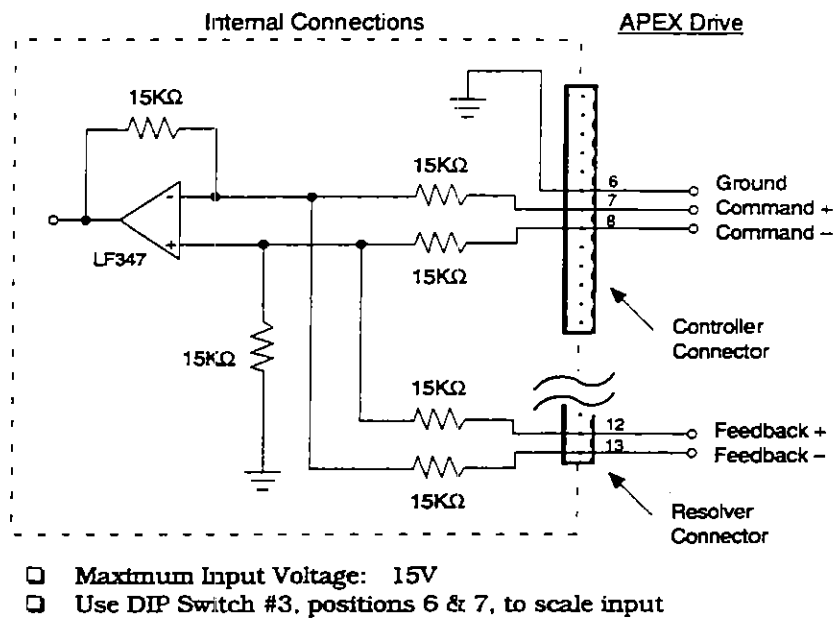

TACHOMETER OUTPUT

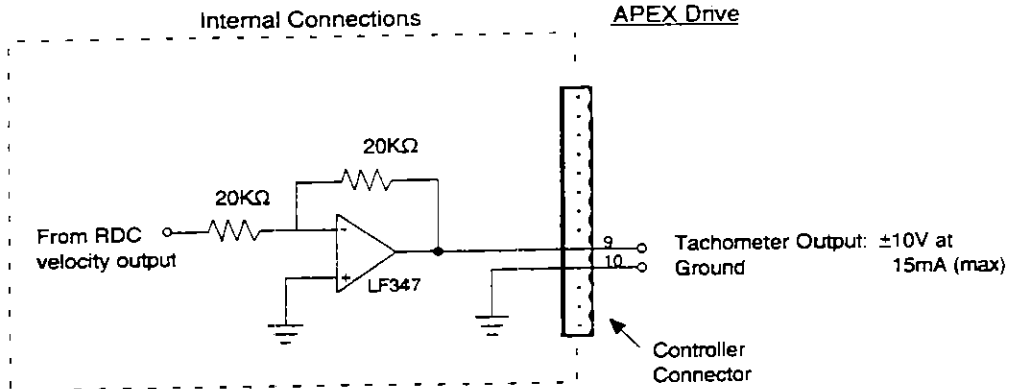

- Use DIP Switch #3, position 5, to scale output:
- OFF = 1V/1000 rpm for one speed resolvers
 - ON = 1V/1000 rpm for two speed resolvers.

±15V OUTPUT

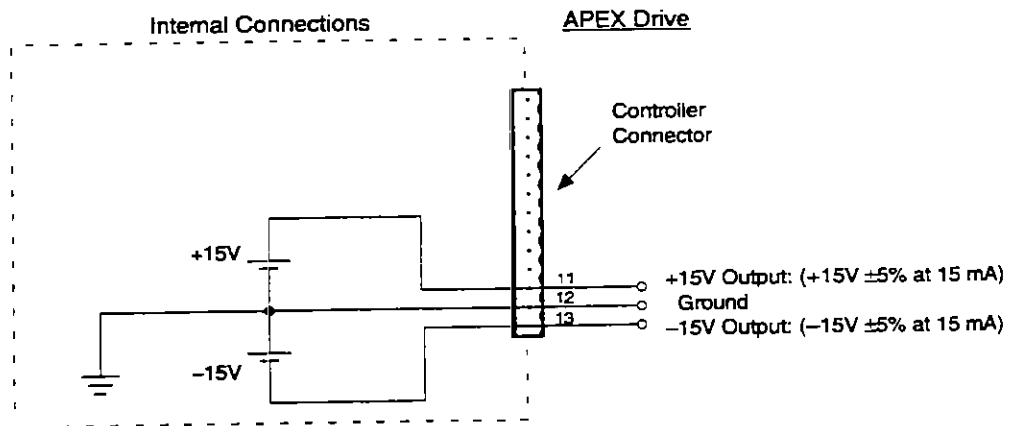

ENCODER CONNECTOR

Encoder Output		Hall Effect Input	
Pin #:	Function:	Pin #:	Function:
1	Channel A+	1	No Connect
2	Channel A-	2	No Connect
3	Channel B+	3	Hall +5VDC
4	Channel B-	4	Hall 1
5	Channel Z+	5	Hall 2
6	Channel Z-	6	Hall 3
7	Ground	7	Hall Ground

Mating Connector:

7 pin screw terminal removable connector
Compumotor P/N 43-013801-01

The encoder connector is a dual use connector. It can be used for either Encoder Output or for Hall Effect Input. Use DIP Switch #3, position 4, to select the desired function.

OFF = Encoder Output mode

ON = Hall Effect Input mode

Schematic diagrams of the Encoder Output circuit and of the Hall Effect Input circuit are shown below.

ENCODER - QUADRATURE OUTPUTS

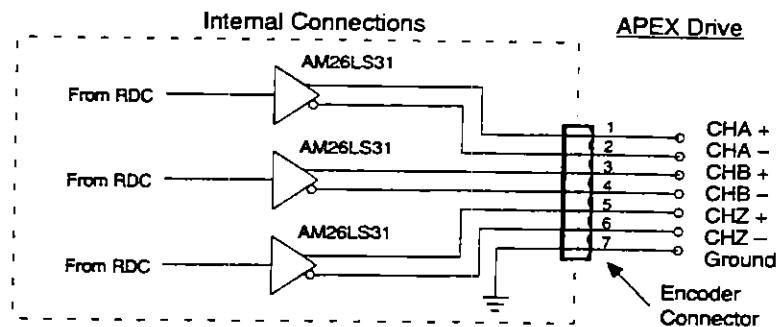

The APEX Drive's encoder outputs are pseudo-quadrature outputs. These quadrature outputs are called *pseudo* because they are hardware derived from resolver information and not from an actual encoder. The resolution is 1024 counts per revolution (pre-quadrature), or 4096 counts per revolution (post-quadrature).

The position of the motor shaft can be determined by counting pulses. The APEX Drive has a *quadrature detect circuit* that enhances resolution. Channels A and B produce two square waves that are 90 electrical degrees apart. By monitoring the rising and falling edges of CHA and CHB, each pulse is equivalent to four counts. In this way, the 1024 counts are translated into 4096 counts, as the next figure shows.

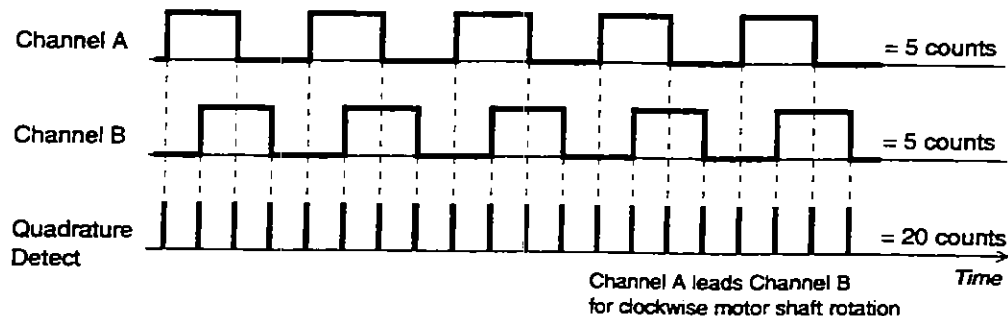

The drive determines direction by comparing the phase shift of Channel A relative to Channel B. For example, if Channel A leads channel B, as shown in the previous drawing, the motor shaft is turning in a clockwise direction.

The quadrature outputs are differential (or complementary) outputs. When Channel A+ goes high, Channel A- goes low, and vice versa. Differential outputs increase the system's noise immunity.

The Z Channel, or marker, provides a reference pulse once per revolution. The Z channel outputs (CHZ+, CHZ-) are differential outputs.

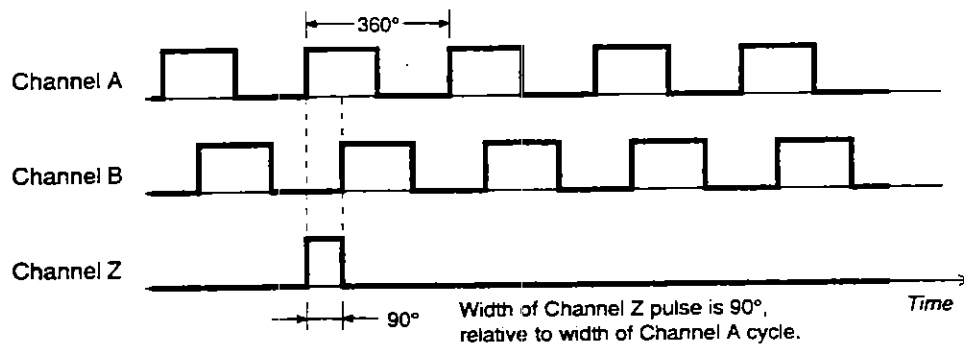

The width of the Z channel pulse, relative to the A channel cycle, is 90°.

HALL EFFECT INPUT

The following circuit is internally connected to the encoder connector when DIP Switch #3, position 4, is in turned ON.

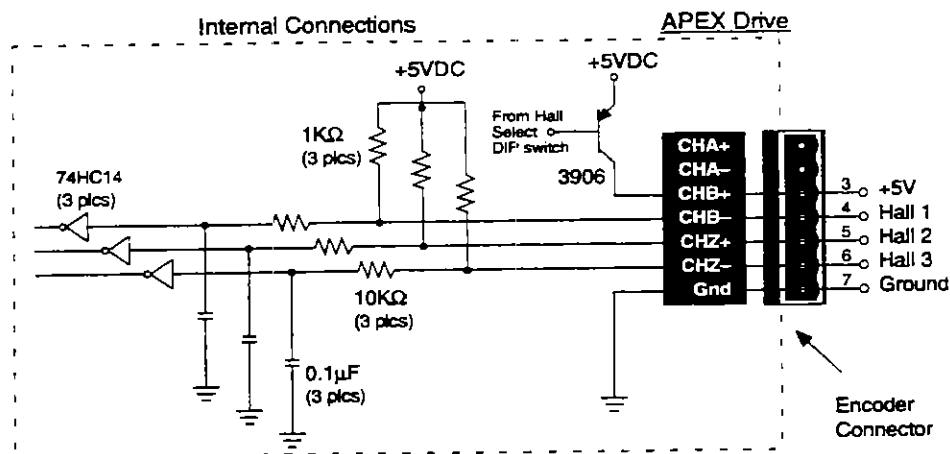

With this circuit active, you can use the connector for Hall effect sensor inputs. The APEX Drive uses the Hall sensor information to determine rotor position, so that it can commutate the motor correctly.

If you use a motor with Hall effect sensors rather than a resolver, connect the Hall cable to the APEX Drive's encoder connector according to the diagram above. Make sure that DIP Switch #3, position #4, is ON BEFORE you power up the drive.

CAUTION

Turn the Hall Select DIP Switch ON before you apply AC power to the APEX Drive. Damage to system components may result from powering up the drive in resolver mode, with Hall effect motors attached.

RESOLVER CONNECTOR

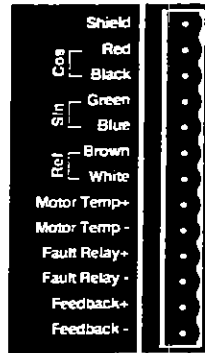

Function	APEX Cable Color Code	SM Cable Color Code
Shield	Uninsulated	Uninsulated
Stator 3	Red	Red
Stator 1	Black	Black
Stator 2	Green	Green
Stator 4	Blue	Blue
Rotor 1	Brown	Brown
Rotor 2	White	White
Motor Temp+	Yellow	Yellow
Motor Temp -	Orange	Yellow
Fault Relay+		
Fault Relay -		
Feedback +		
Feedback -		

Mating Connector:
13 pin screw terminal removable connector
Compumotor P/N 43-013802-01

Schematic diagrams of each input and output on the resolver connector are shown below.

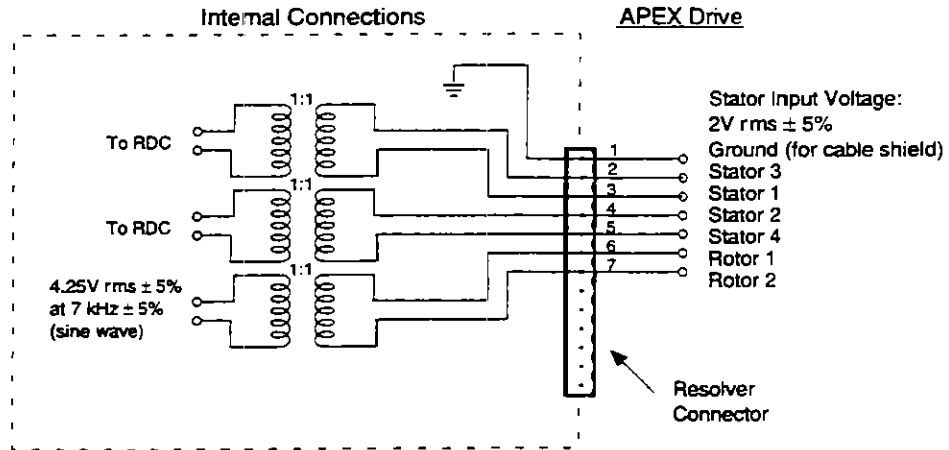

- ❑ DIP Switch #3, position 4, must be OFF so that:
 - Internal microprocessor uses resolver information for commutation
 - Encoder output will be enabled
 - Hall Effect input will be disabled
- ❑ Shield (on the resolver connector) is internally connected to all ground terminals (labeled Gnd) on the APEX Drive's front panel. These terminals are isolated from Earth and Motor Ground, and from the chassis.

MOTOR TEMP±

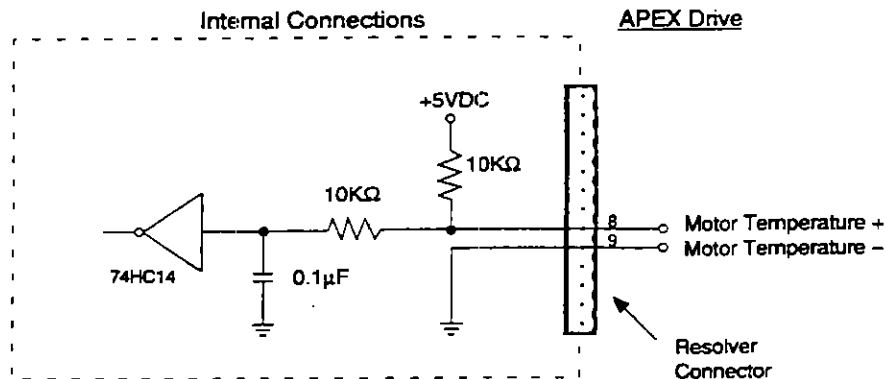

MOTOR TEMP± (continued)

- ❑ Motor's temperature sensor should be *normally closed* (closed at low temperatures; opens at high temperatures.)
- ❑ Short together Motor Temp+ and Motor Temp- if motor does not have a temperature sensor.

FAULT RELAY ±

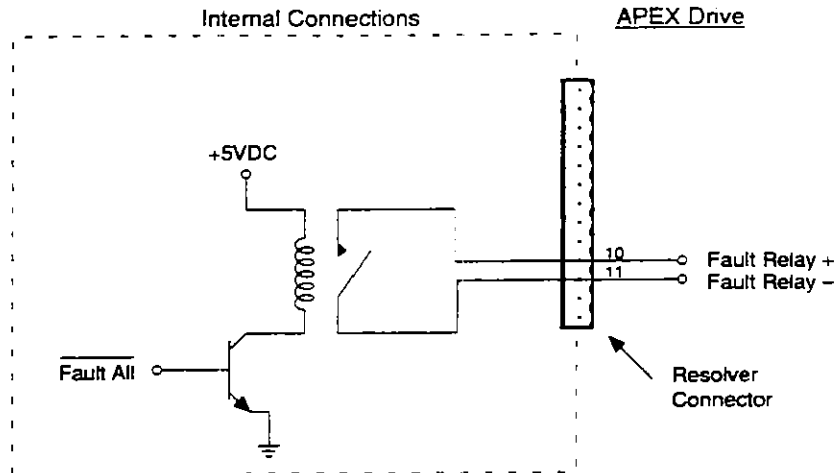

- ❑ Relay Type: Normally Open
 - Relay will be *OPEN* if drive is disabled, faulted, or power is off
 - Relay will be *CLOSED* when drive is enabled
- ❑ Maximum current rating: 5A at 24VDC, or 5A at 120VAC
- ❑ For more information, see *Motor Braking* in Chapter 3 Special Features

FEEDBACK ±

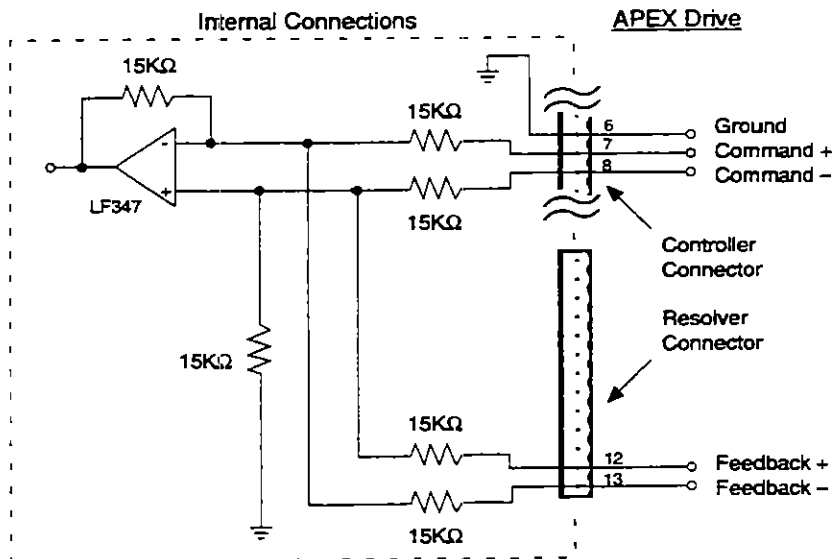

- ❑ Use for velocity mode operation

MOTOR SPECIFICATIONS

Speed/torque curves, motor specifications, and dimensions are shown on the following pages.

MOTOR BRAKES

Motor brakes are mounted directly behind the motor and are pre-assembled at the factory. When ordering the brake option, specify the motor type.

Brake Characteristics	APEX602	APEX603	APEX604	APEX605	APEX620	APEX640
				APEX606	APEX630	
Supply voltage (VDC)	24	24	24	24	24	24
Supply current (amps)	0.57	1.27	0.57	1.27	0.93	1.27
Static braking torque (oz-in)	326	850	326	850	1130	6800
(Nm)	2.3	6.0	2.3	6.0	8.0	48

MOTOR CABLES

SM motor cables are available in 10 and 25 foot lengths; APEX motor cables are available in 10, 25, 50, and 100 foot lengths. You can also order custom cables of any length. Call Compumotor's Customer Service Department (800-722-2282). Cable lengths in excess of 100 feet are not recommended.

MOTOR DATA

The data sheets do not assume operation from an APEX drive. The torque specifications reflect the motor's capabilities. In most cases, the motor windings match the drive's output power with an additional safety margin.

POSITIONAL REPEATABILITY

Repeatability: ± 0.088 degrees, unloaded

POSITIONAL ACCURACY

Resolver Accuracy: ± 10 arc minutes

Resolver-to-Digital Converter Accuracy: ± 10 arc minutes

SELECTING DRIVE/MOTOR COMBINATIONS

We recommend selecting motors for use with APEX Drives as follows:

APEX10 Drive:	SM-231A, SM232A, SM-233B, APEX602, APEX603
APEX20 Drive:	APEX604, APEX605, APEX606
APEX40 Drive:	APEX610, APEX620, APEX630, APEX635, APEX640

SPEED/TORQUE CURVES

Speed/torque curves on these pages represent the available shaft torque at different operating speeds, under the following conditions:

SM Motors:

25° C (77°F) ambient temperature
Nominal torque constant K_t
Motor mounted to heatsink:
10" x 10" x 0.25" aluminum

APEX Motors:

40°C (104°F) ambient temperature
Nominal torque constant K_t
Motor mounted to aluminum heatsink:
8" x 12" x 0.25" for APEX602 – APEX630
11.5" x 12" x 0.75" for APEX635, APEX640

Actual motor torque may vary $\pm 10\%$ due to motor manufacturing variances.

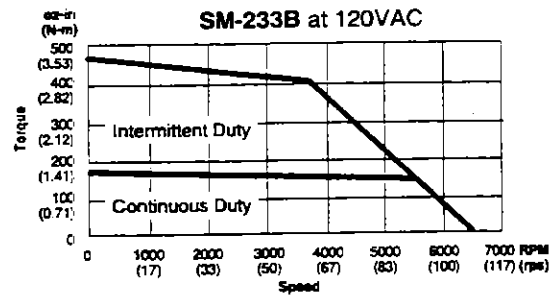
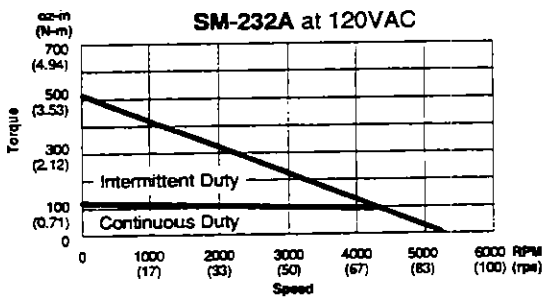
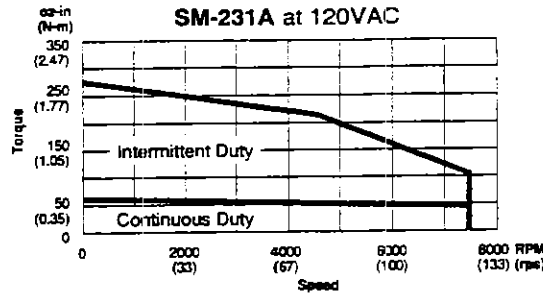

SM Series Motors – Speed Torque Curves

CAUTION

SM Series Servo Motors are optimized for operation with APEX Drives at 120VAC. Do not power the drive with 240VAC if you use an SM Motor.

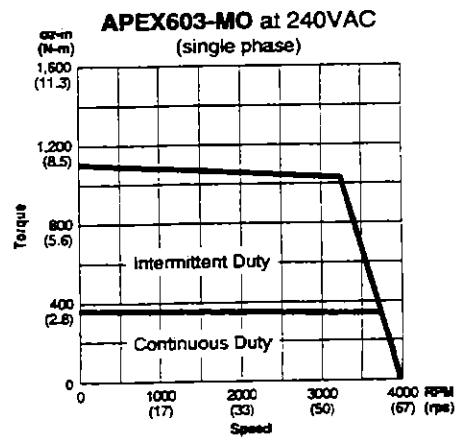
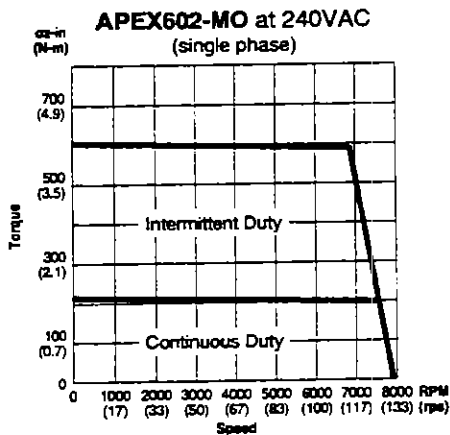

APEX602, APEX603 Speed Torque Curves

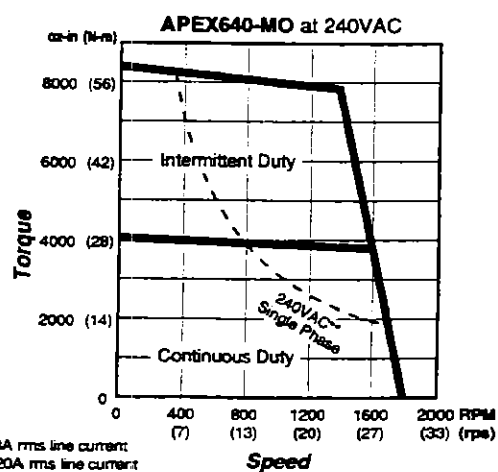
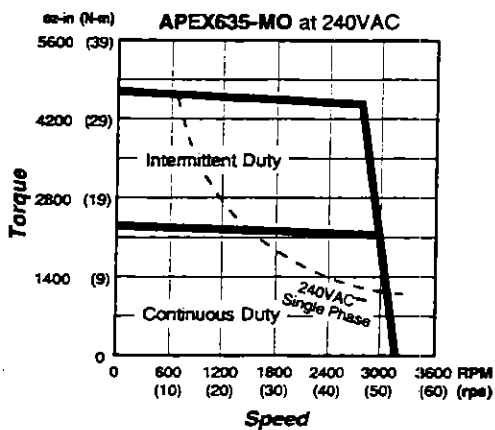
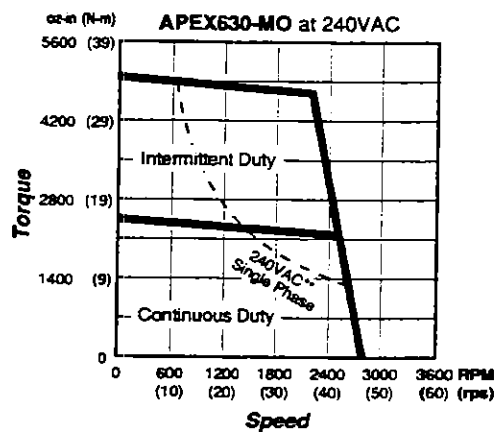
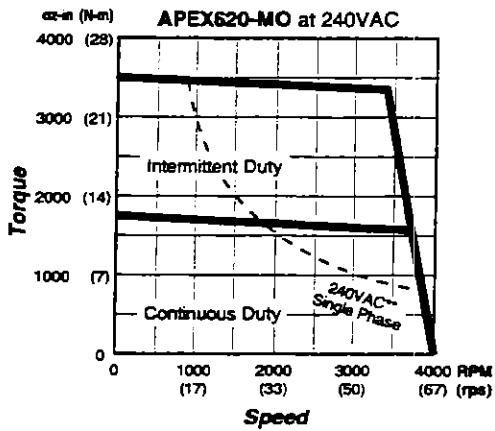
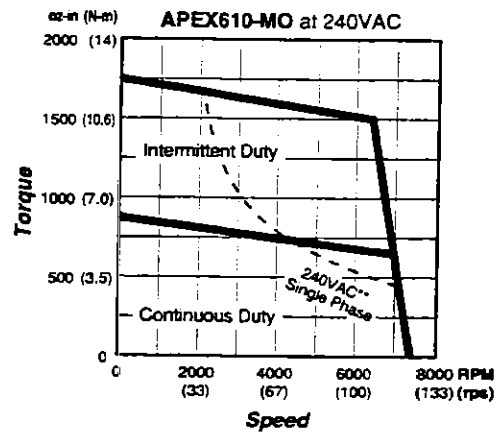
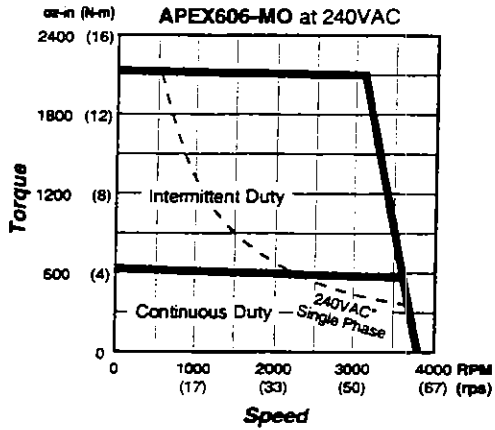
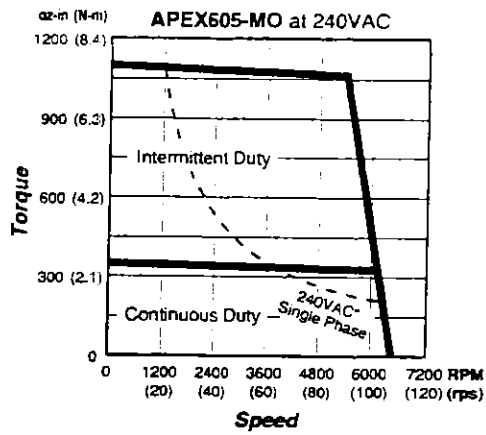
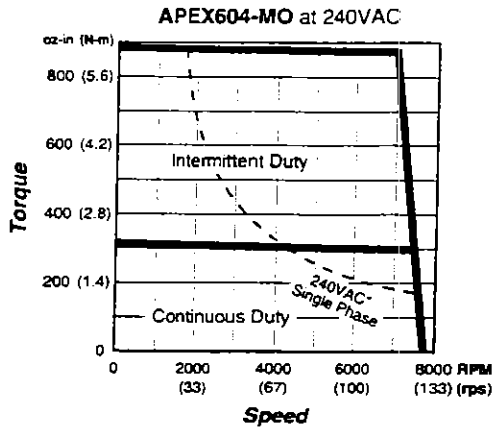

*240VAC single phase, 8A rms line current;
 **240VAC single phase, 20A rms line current

SM Motor Specifications

Parameter	Symbol	Units	SM231AR	SM232AR	SM233BR
Stall Torque Continuous ¹	T_{cs}	lb.in.	3.5	6.7	10.2
		oz. in.	56	107	163
		Nm	0.40	0.76	1.15
Stall Current Continuous ¹	I_{cs}	amperes - rms	2.0	2.0	3.9
Rated Speed	ω_r	rpm	7500	4250	6000
		rps	125	71	100
Peak Torque ¹	T_{pk}	lb.in.	17.5	33.4	50.9
		oz. in.	280	535	815
		Nm	1.98	3.78	5.76
Peak Current, rms ¹	I_{pk}	amperes	10	10	19.5
Torque @ Rated Speed ¹	T_c	lb.in.	2.8	6.0	9.0
		oz. in.	46	96	145
		Nm	0.32	0.68	1.02
Rated Power -- Output Shaft ¹	P_o	watts	250	302	643
		hp	0.34	0.40	0.86
Voltage Constant ^{3,4,6}	K_b	volts/radian/sec	0.161	0.310	0.242
Voltage Constant ^{3,4,6}	K_e	volts/KRPM	16.86	32.45	25.33
Torque Constant ^{3,4,6}	K_t	oz. in./ amp rms	22.80	43.89	34.23
		Nm/amp rms	0.16	0.31	0.24
Resistance ^{2,3}	R	ohms	5.22	7.5	2.58
Inductance ⁵	L	millihenries	1.64	2.9	1.06
Thermal Resistance ¹	R_{th}	°C/watt	2.23	1.58	1.26
Motor Constant	K_m	oz.in./√watt	9.58	15.99	21.25
		Nm/√watt	0.07	0.11	0.15
Viscous Damping	B	oz. in./Krpm	1.24	2.07	2.86
		Nm/Krpm	8.76×10^{-3}	14.76×10^{-3}	20.20×10^{-3}
Torque - Static Friction	T_f	oz. in.	1.2	2.0	2.25
		Nm	8.47×10^{-3}	14.10×10^{-3}	15.90×10^{-3}
Thermal Time Constant	τ_{th}	minutes	30	35	40
Electrical Time Constant	τ_e	milliseconds	0.31	0.39	0.41
Mechanical Time Constant	τ_m	milliseconds	13.7	8.6	7.0
Rotor Inertia	J	lb.in.sec ²	0.00048	0.00084	0.00119
		kgm ² 1E-6	54.23	94.91	134.50
Weight	#	pounds	2.6	3.5	4.4
		kg	1.18	1.59	2.00
Winding Class			H	H	H

¹ @ 25°C ambient w/ 10x10x0.25 inch mounting plate. 150°C winding temperature
For 40°C ambient operation, reduce values by 12%.

³ ± 10%, line-to-line

⁴ peak value

⁵ ± 30%, line-to-line, inductance bridge measurement method @ 1KHz

⁶ Performance with AC sinusoidal amplifiers can be approximated by review of the amplifiers phase current specification, determining whether ratings are RMS or Peak values. For peak current values, multiply K_t by 0.86. If specified as RMS, multiply K_t by 1.22.

All specifications are subject to engineering change

APEX and SM Resolver Specifications

Parameter	Value
Input voltage @ 7000 Hz	4.25 volts
Input current, max.	55 mA
Input power, nominal	0.12 watts
Impedance ZSO (@90°)	58 +j145 ohms
Impedance ZRO	53 +j72 ohms
Impedance ZRS	42 +j55 ohms
Transformation ratio	0.470 ±5%
Output voltage	2.0 ±5% volts
D.C. rotor resistance	23 ±10% ohms
D.C. stator resistance	19 ±10% ohms
Sensitivity	35 mV/Degree
Max. Error from EZ	±10 minutes
Phase shift, open circuit	5° leading ±3°
Null voltage (total)	20 mV rms
Impedance ZSS	50 +j128 ohms
Inertia	included in motor specification

	Motor Size:	APEX602	Value	Units	Tolerance	
1	Constant (s):	Torque	52.6 (0.37)	oz-in/A rms (Nm/A rms)	± 10%	
2		Voltage (Sinusoidal)	22.5	V rms/Krpm	± 10%	
3		Electrical Time	5.3	milliseconds	nominal	
4		Mechanical Time	1.40	milliseconds	nominal	
5		Thermal	11.0	minutes	nominal	
6	Torque (s): (NOTE: Values are with rated and peak current, lines 15 & 16 below. Drive current, and thus torque, may be lower.)	Continuous, Stall	236 (1.67)	oz-in (Nm)	min. [1]	
7		Continuous, Stall	223 (1.57)	oz-in (Nm)	min. [2]	
8		Continuous, Rated	202 (1.43)	oz-in (Nm)	min. [2]	
9		Peak, Max w/o Saturation	630 (4.45)	oz-in (Nm)	min. [1]	
10		Static Friction	7.68 (0.05)	oz-in (Nm)	max.	
11		Ripple (of Rated Torque)	5	percent	max. [3]	
12	Speed:	Rated	7500 (125)	rpm (rps)	reference	
13		Maximum	7500 (125)	rpm (rps)	reference	
14	Frequency	Rated	250	Hz	max.	
15	Current:	Rated	4.2	A rms	max. [1]	
16		Peak	12.6	A rms	nominal	
17	Voltage:	Rated	240	V rms	reference	
18		Max	250	V rms	maximum	
19	Output Power	Rated	1.12 (1.5)	kWatts (hp)	min. [1]	
20	Inductance	Terminal (line-line)	14.4	mH	± 30%	
21	D.C. Resistance	Terminal (line-line)	2.72	ohms	± 10 % [1]	
22	Acceleration at Rated Torque		96500	rads/sec ²	Theoretical	
23	Rotor Inertia		2.52 (46.1)	oz-in ² (kgm ² * 1E-6)	nominal	
24	Damping		0.384 (0.0027)	oz-in/krpm (Nm/krpm)	nominal	
25	Weight		7.0 (3.17)	lbs. (kg)	max.	
26	Winding Temperature		170°C (338°F) [4]	°C (°F)	max.	
27	Winding Temperature Rise (Above Ambient) [1]		145°C (293°F)	°C (°F)	reference	
28	Insulation Class		H	—	reference	
29	Thermostat TRIP Temperature		170°C (338°F)	°C (°F)	± 5° C	
30	Thermostat RESET Temperature		135°C (275°F)	°C (°F)	± 10° C	
31	Dielectric Strength, (Winding-to-Frame)		1750	VAC	min.	
32	Winding Capacitance-to-Frame		0.000898	µF	max.	
33	IP Classification		65 [8]	rated	standard	
34	Shaft:	Radial-Play	At End	12E-6 (68E-9)	in/lb (m/N)	reference
				At Faceplate	7.0E-6 (40E-9)	in/lb (m/N)
35		Material [5]		RC-#30	—	reference
36		Magnet Type		NdFeB	—	—
37		Loading [6]	1000 rpm (17 rps)	81 (360)	lbs. (N)	max. [7]
			2000 rpm (33 rps)	65 (289)	lbs. (N)	max. [7]
			3000 rpm (50 rps)	56 (249)	lbs. (N)	max. [7]
			4000 rpm (67 rps)	51 (227)	lbs. (N)	max. [7]
			5000 rpm (83 rps)	48 (213)	lbs. (N)	max. [7]
38	Motor Vibration		N	ISO 2373	Standard	
39	Bearing Class, Internal/External		1/Class 3	ABEC/AFBMA	reference	
40	Bearing Grease		SRI #2	Manufacturer	reference	
41	Shaft Seal Pressure		3 (0.21)	psi (kg/cm ²)	max.	
42	Basic Motor Design		3 phase wye connected 2(P/2)			
43	Stator Phase Sequence		A-C-B (viewed from front face plate)			
44	Vendor/Supplier		Industrial Drives B-104-B			
45	Resolver Type/Accuracy		Single-Speed; Rotor-Excited; ± 10 arc min.			
46	Resolver Manufacturer/Model #		Fasco # 21-BRCX-335-J39			
47	Standard Resolver Cable Part Number		71-011777-xx			
48	Standard Motor Cable Part Number		71-011774-xx			
49	Options:	Brake—24VDC (0.57A)—326 oz-in (2.3 Nm) Holding Torque		(requires resolver cable 71-014082-xx)		
		IP67 Classification	No Keyway			
		Incremental Encoder	Shaft Modifications			
		Tachometer	IP65 Shaft Seal			
[1]	25°C (77°F) Ambient		[5] Rotor steel is rated as <i>fatigue proof</i>			
[2]	40°C (104°F) Ambient		[6] Loads centered 1 inch from mounting flange			
[3]	Measured at 60 rpm (1 rps) in Velocity Mode		[7] Loads may be radial and axial such that the sum of the radial and two times the axial does not exceed this figure.			
[4]	Rated for 20,000 Hours or 40,000 Hours @ 155° C (311°F)		[8] Motor shaft is IP30 rated.			

APEX602 Motor Specifications

Motor Size: APEX603		Value	Units	Tolerance		
1	Constant (s):	Torque	114.6 (0.81)	oz-in/A rms (Nm/A rms)	± 10%	
2		Voltage (Sinusoidal)	49.0	V rms/Krpm	± 10%	
3		Electrical Time	9.7	milliseconds	nominal	
4		Mechanical Time	—	milliseconds	nominal	
5		Thermal	18	minutes	nominal	
6	Torque (s):	Continuous, Stall	367 (2.59)	oz-in (Nm)	min. [1]	
7	(NOTE: Values are with	Continuous, Stall	346 (2.44)	oz-in (Nm)	min. [2]	
8	rated and peak current,	Continuous, Rated	356 (2.51)	oz-in (Nm)	min. [2]	
9	lines 15 & 16 below.	Peak, Max w/o Saturation	1046 (7.38)	oz-in (Nm)	min. [1]	
10	Drive current, and thus	Static Friction	12.0 (0.08)	oz-in (Nm)	max.	
11	torque, may be lower.)	Ripple (of Rated Torque)	5	percent	max. [3]	
12	Speed:	Rated	3800 (63)	rpm (rps)	reference	
13		Maximum	3800 (63)	rpm (rps)	reference	
14	Frequency	Rated	126.7	Hz	max.	
15	Current:	Rated	3.0	A rms	max. [1]	
16		Peak	9.6	A rms	nominal	
17	Voltage:	Rated	240	V rms	reference	
18		Max	250	V rms	maximum	
19	Output Power	Rated	1.0 (1.3)	kWatts (hp)	min. [1]	
20	Inductance	Terminal (line-line)	68	mH	± 30%	
21	D.C. Resistance	Terminal (line-line)	7.0	ohms	± 10 % [1]	
22	Acceleration at Rated Torque		74150	rads/sec ²	Theoretical	
23	Rotor Inertia		5.45 (99.6)	oz-in ² (kgm ² * 1E-6)	nominal	
24	Damping		0.960 (0.0068)	oz-in/krpm (Nm/krpm)	nominal	
25	Weight		9.0 (4.08)	lbs. (kg)	max.	
26	Winding Temperature		170°C (338°F) [4]	°C (°F)	max.	
27	Winding Temperature Rise (Above Ambient) [1]		145°C (293°F)	°C (°F)	reference	
28	Insulation Class		H	—	reference	
29	Thermostat TRIP Temperature		170°C (338°F)	°C (°F)	± 5° C	
30	Thermostat RESET Temperature		135°C (275°F)	°C (°F)	± 10° C	
31	Dielectric Strength, (Winding-to-Frame)		1750	VAC	min.	
32	Winding Capacitance-to-Frame		0.00122	µF	max.	
33	IP Classification		65 [8]	rated	standard	
34	Shaft:	Radial-Play	At End	14E-6 (80E-9)	in/lb (m/N)	reference
			At Faceplate	8.0E-6 (45E-9)	in/lb (m/N)	reference
35		Material [5]		RC-#30	—	reference
36		Magnet Type		NdFeB	—	—
37		Loading [6]	1000 rpm (17 rps)	85.4 (380)	lbs. (N)	max. [7]
			2000 rpm (33 rps)	67.8 (302)	lbs. (N)	max. [7]
			3000 rpm (50 rps)	59.1 (263)	lbs. (N)	max. [7]
			4000 rpm (67 rps)	53.8 (239)	lbs. (N)	max. [7]
			5000 rpm (83 rps)	50 (222)	lbs. (N)	max. [7]
38	Motor Vibration		N	ISO 2373	Standard	
39	Bearing Class, Internal/External		1/Class 3	ABEC/AFBMA	reference	
40	Bearing Grease		SRI #2	Manufacturer	reference	
41	Shaft Seal Pressure		3 (0.21)	psi (kg/cm ²)	max.	
42	Basic Motor Design		3 phase wye connected 2(P/2)			
43	Stator Phase Sequence		A-C-B (viewed from front face plate)			
44	Vendor/Supplier		Industrial Drives B-202-B			
45	Resolver Type/Accuracy		Single-Speed; Rotor-Excited; ± 10 arc min.			
46	Resolver Manufacturer/Model #		Fasco # 21-BRCX-335-J39			
47	Standard Resolver Cable Part Number		71-011777-xx			
48	Standard Motor Cable Part Number		71-011774-xx			
49	Options:	Brake—24VDC (0.57A)—845	oz-in (5.97 Nm) Holding Torque	(requires resolver cable 71-014082-xx)		
		IP67 Classification	No Keyway			
		Incremental Encoder	Shaft Modifications			
		Tachometer	IP65 Shaft Seal			
[1]	25°C (77°F) Ambient					
[2]	40°C (104°F) Ambient					
[3]	Measured at 60 rpm (1 rps) in Velocity Mode					
[4]	Rated for 20,000 Hours or 40,000 Hours					
	① 155° C (311°F)					
[5]	Rotor steel is rated as <i>fatigue proof</i>					
[6]	Loads centered 1 inch from mounting flange					
[7]	Loads may be radial and axial such that the sum of the radial and two times the axial does not exceed this figure.					
[8]	Motor shaft is IP30 rated.					

APEX603 Motor Specifications

Motor Size: APEX604		Value	Units	Tolerance
1	Constant (s):	Torque	52.6 (0.37)	oz-in/A rms (Nm/A rms)
2		Voltage (Sinusoidal)	22.5	V rms/Krpm
3		Electrical Time	58.7	milliseconds
4		Mechanical Time	1.30	milliseconds
5		Thermal	12	minutes
6	Torque (s):	Continuous, Stall	334 (2.36)	oz-in (Nm)
7	(NOTE: Values are with rated and peak current, lines 15 & 16 below. Drive current, and thus torque, may be lower.)	Continuous, Stall	315 (2.22)	oz-in (Nm)
8		Continuous, Rated	269 (1.90)	oz-in (Nm)
9		Peak, Max w/o Saturation	899 (6.35)	oz-in (Nm)
10		Static Friction	9.6 (0.07)	oz-in (Nm)
11		Ripple (of Rated Torque)	5	percent
12	Speed:	Rated	7500 (125)	rpm (rps)
13		Maximum	7500 (125)	rpm (rps)
14	Frequency	Rated	250	Hz
15	Current:	Rated	6.0	A rms
16		Peak	18.8	A rms
17	Voltage:	Rated	240	V rms
18		Max	250	V rms
19	Output Power	Rated	1.5 (2.0)	kWatts (hp)
20	Inductance	Terminal (line-line)	9.4	mH
21	D.C. Resistance	Terminal (line-line)	1.6	ohms
22	Acceleration at Rated Torque		82980	rads/sec ²
23	Rotor Inertia		4.18 (76.5)	oz-in ² (kgm ² * 1E-6)
24	Damping		0.580 (0.0041)	oz-in/krpm (Nm/krpm)
25	Weight		8.5 (3.86)	lbs. (kg)
26	Winding Temperature		170°C (338°F) [4]	°C (°F)
27	Winding Temperature Rise (Above Ambient) [1]		145°C (293°F)	°C (°F)
28	Insulation Class		H	—
29	Thermostat TRIP Temperature		170°C (338°F)	°C (°F)
30	Thermostat RESET Temperature		135°C (275°F)	°C (°F)
31	Dielectric Strength, (Winding-to-Frame)		1750	VAC
32	Winding Capacitance-to-Frame		0.00122	µF
33	IP Classification		65 [8]	rated
34	Shaft: Radial-Play	At End	12E-6 (68E-9)	in/lb (m/N)
		At Faceplate	5.6E-6 (32E-9)	in/lb (m/N)
35	Material [5]		RC-#30	—
36	Magnet Type		NdFeB	—
37	Loading [6]	1000 rpm (17 rps)	84 (374)	lbs. (N)
		2000 rpm (33 rps)	67 (298)	lbs. (N)
		3000 rpm (50 rps)	58 (258)	lbs. (N)
		4000 rpm (67 rps)	53 (236)	lbs. (N)
		5000 rpm (83 rps)	49 (218)	lbs. (N)
38	Bearing Class, Internal/External		1/Class 3	ABEC/AFBMA
39	Bearing Grease		SRI #2	Manufacturer
40	Shaft Seal Pressure		3 (0.21)	psi (kg/cm ²)
41	Basic Motor Design		3 phase wye connected 2(P/2)	max.
42	Stator Phase Sequence		A-C-B (viewed from front face plate)	
43	Vendor/Supplier		Industrial Drives B-106-B	
44	Resolver Type/Accuracy		Single-Speed; Rotor-Excited; ± 10 arc min.	
45	Resolver Manufacturer/Model #		Fasco # 21-BRCX-335-J39	
46	Standard Resolver Cable Part Number		71-013862-xx	
47	Standard Motor Cable Part Number		71-013863-xx	
48	Options:	Brake—24VDC (0.57A)—326 oz-in (2.3 Nm) Holding Torque IP67 Classification Incremental Encoder Tachometer No Keyway		

[1] 25°C (77°F) Ambient
 [2] 40°C (104°F) Ambient
 [3] Measured at 60 rpm (1 rps) in Velocity Mode
 [4] Rated for 20,000 Hours or 40,000 Hours @ 155°C (311°F)

[5] Rotor steel is rated as *fatigue proof*
 [6] Loads centered 1 inch from mounting flange
 [7] Loads may be radial and axial such that the sum of the radial and two times the axial does not exceed this figure.
 [8] Motor shaft is IP30 rated.

APEX604 Motor Specifications

	Motor Size:	APEX605		Value	Units	Tolerance
1	Constant (s):	Torque		68.7 (0.49)	oz-in/A rms (Nm/A rms)	± 10%
2		Voltage (Sinusoidal)		29.4	V rms/Krpm	± 10%
3		Electrical Time		10.68	milliseconds	nominal
4		Mechanical Time		1.46	milliseconds	nominal
5		Thermal		18	minutes	nominal
6	Torque (s):	Continuous, Stall		367 (2.59)	oz-in (Nm)	min. [1]
7	(NOTE: Values are with	Continuous, Stall		346 (2.44)	oz-in (Nm)	min. [2]
8	rated and peak current,	Continuous, Rated		321 (2.27)	oz-in (Nm)	min. [2]
9	lines 15 & 16 below.	Peak, Max w/o Saturation		1085 (7.66)	oz-in (Nm)	min. [1]
10	Drive current, and thus	Static Friction		0.96 (0.007)	oz-in (Nm)	max.
11	torque, may be lower.)	Ripple (of Rated Torque)		5	percent	max. [3]
12	Speed:	Rated		6200 (103)	rpm (rps)	reference
13		Maximum		6200 (103)	rpm (rps)	reference
14	Frequency	Rated		207	Hz	max.
15	Current:	Rated		5	A rms	max. [1]
16		Peak		16.6	A rms	nominal
17	Voltage:	Rated		240	V rms	reference
18		Max		250	V rms	maximum
19	Output Power	Rated		1.5 (2.0)	kWatts (hp)	min. [1]
20	Inductance	Terminal (line-line)		25	mH	± 30%
21	D.C. Resistance	Terminal (line-line)		2.3	ohms	± 10 % [1]
22	Acceleration at Rated Torque			76870	rads/sec ²	Theoretical
23	Rotor Inertia			5.43 (99.6)	oz-in ² (kgm ² * 1E-6)	nominal
24	Damping			0.96 (0.0068)	oz-in/krpm (Nm/krpm)	nominal
25	Weight			10 (4.5)	lbs. (kg)	max.
26	Winding Temperature			170°C (338°F) [4]	°C (°F)	max.
27	Winding Temperature Rise (Above Ambient) [1]			145°C (293°F)	°C (°F)	reference
28	Insulation Class			H	—	reference
29	Thermostat TRIP Temperature			170°C (338°F)	°C (°F)	± 5° C
30	Thermostat RESET Temperature			135°C (275°F)	°C (°F)	± 10° C
31	Dielectric Strength, (Winding-to-Frame)			1750	VAC	min.
32	Winding Capacitance-to-Frame			0.00122	µF	max.
33	IP Classification			65 [8]	rated	standard
34	Shaft:	Radial-Play	At End	14E-6 (80E-9)	in/lb (m/N)	reference
			At Faceplate	8E-6 (45E-9)	in/lb (m/N)	reference
35	Material [5]			RC #30	—	—
36	Magnet Type			NdFeB	—	—
37	Loading [6]	1000 rpm (17 rps)		85.4 (380)	lbs. (N)	max. [7]
		2000 rpm (33 rps)		67.8 (301)	lbs. (N)	max. [7]
		3000 rpm (50 rps)		59.1 (263)	lbs. (N)	max. [7]
		4000 rpm (67 rps)		53.8 (239)	lbs. (N)	max. [7]
		5000 rpm (83 rps)		50 (222)	lbs. (N)	max. [7]
38	Bearing Class, Internal/External			1/Class 3	ABEC/AFBMA	reference
39	Bearing Grease			SRI #2	Manufacturer	reference
40	Shaft Seal Pressure			3 (0.21)	psi (kg/cm ²)	max.
41	Basic Motor Design			3 phase wye connected 2(P/2)		
42	Stator Phase Sequence			A-C-B (viewed from front face plate)		
43	Vendor/Supplier			Industrial Drives B-202-C		
44	Resolver Type/Accuracy			Single-Speed; Rotor-Excited; ± 10 arc min.		
45	Resolver Manufacturer/Model #			Fasco # 21-BRCX-335-J39		
46	Standard Resolver Cable Part Number			71-013862-xx		
47	Standard Motor Cable Part Number			71-013863-xx		
48	Options:	Brake—24VDC (0.57A)—850 oz-in (6.0 Nm) Holding Torque				
		IP67 Classification				
		Incremental Encoder				
		Tachometer				
		No Keyway				
[1]	25°C (77°F) Ambient			[5] Rotor steel is rated as <i>fatigue proof</i>		
[2]	40°C (104°F) Ambient			[6] Loads centered 1 inch from mounting flange		
[3]	Measured at 60 rpm (1 rps) in Velocity Mode			[7] Loads may be radial and axial such that the sum of the radial and two times the axial does not exceed this figure.		
[4]	Rated for 20,000 Hours or 40,000 Hours			[8] Motor shaft is IP30 rated.		
	@ 155° C (311°F)					

	Motor Size:	APEX606	Value	Units	Tolerance	
1	Constant (s):	Torque	120 (0.85)	oz-in/A rms (Nm/A rms)	± 10%	
2		Voltage (Sinusoidal)	51.2	V rms/Krpm	± 10%	
3		Electrical Time	15.32	milliseconds	nominal	
4		Mechanical Time	0.896	milliseconds	nominal	
5		Thermal	20	minutes	nominal	
6	(NOTE: Values are with rated and peak current. lines 15 & 16 below. Drive current, and thus torque, may be lower.)	Torque (s): Continuous, Stall	672 (4.75)	oz-in (Nm)	min. [1]	
7		Continuous, Stall	634 (4.48)	oz-in (Nm)	min. [2]	
8		Continuous, Rated	576 (4.07)	oz-in (Nm)	min. [2]	
9		Peak, Max w/o Saturation	1957 (13.82)	oz-in (Nm)	min. [1]	
10		Static Friction	0.96 (0.007)	oz-in (Nm)	max	
11		Ripple (of Rated Torque)	5	percent	max. [3]	
12	Speed:	Rated	3600 (60)	rpm (rps)	reference	
13		Maximum	3600 (60)	rpm (rps)	reference	
14	Frequency	Rated	120	Hz	max.	
15	Current:	Rated	5.3	A rms	max. [1]	
16		Peak	17.2	A rms	nominal	
17	Voltage:	Rated	240	V rms	reference	
18		Max	250	V rms	maximum	
19	Output Power:	Rated	1.6 (2.1)	kWatts (hp)	min. [1]	
20	Inductance:	Terminal (line-line)	38	mH	± 30%	
21	D.C. Resistance	Terminal (line-line)	2.48	ohms	± 10 % [1]	
22	Acceleration at Rated Torque		80000	rads/sec ²	Theoretical	
23	Rotor Inertia		9.44 (172.9)	oz-in ² (kgm ² * 1E-6)	nominal	
24	Damping		1.344 (0.0095)	oz-in/krpm (Nm/krpm)	nominal	
25	Weight		13.4 (6.1)	lbs. (kg)	max.	
26	Winding Temperature		170°C (338°F) [4]	°C (°F)	max.	
27	Winding Temperature Rise (Above Ambient) [1]		145°C (293°F)	°C (°F)	reference	
28	Insulation Class		H	—	reference	
29	Thermostat TRIP Temperature		170°C (338°F)	°C (°F)	± 5 °C	
30	Thermostat RESET Temperature		135°C (275°F)	°C (°F)	± 10 °C	
31	Dielectric Strength, (Winding-to-Frame)		1750	VAC	min.	
32	Winding Capacitance to Frame		0.00201	µF	max.	
33	IP Classification		65 [8]	rated	standard	
34	Shaft:	Radial-Play	At End	14E-6 (80E-9)	in/lb (m/N)	reference
			At Faceplate	8E-6 (45E-9)	in/lb (m/N)	reference
35		Material [5]		RC-#30	—	
36		Magnet Type		NdFeB	—	
37	Loading [6]	1000 rpm (17 rps)	90.1 (401)	lbs. (N)	rmax. [7]	
		2000 rpm (33 rps)	71.6 (318)	lbs. (N)	max. [7]	
		3000 rpm (50 rps)	62.4 (278)	lbs. (N)	max. [7]	
		4000 rpm (67 rps)	N/A	lbs. (N)	max. [7]	
		5000 rpm (83 rps)	N/A	lbs. (N)	max. [7]	
38	Bearing Class, Internal/External		1/Class 3	ABEC/AFBMA	reference	
39	Bearing Grease		SRI #2	Manufacturer	reference	
40	Shaft Seal Pressure		3 (0.21)	psi (kg/cm ²)	max.	
41	Basic Motor Design		3 phase wye connected 2(P/2)			
42	Stator Phase Sequence		A-C-B (viewed from front face plate)			
43	Vendor/Supplier		Industrial Drives B-204-B			
44	Resolver Type/Accuracy		Single-Speed; Rotor-Excited; ± 10 arc min.			
45	Resolver Manufacturer/Model #		Fasco # 21-BRCX-335-J39			
46	Standard Resolver Cable Part Number		71-013862-xx			
47	Standard Motor Cable Part Number		71-013863-xx			
48	Options:	Brake—24VDC (0.57A)—850 oz-in (6.0 NM) Holding Torque IP67 Classification Incremental Encoder Tachometer No Keyway				
[1]	25°C (77°F) Ambient		[5] Rotor steel is rated as <i>fatigue proof</i>			
[2]	40°C (104°F) Ambient		[6] Loads centered 1 inch from mounting flange			
[3]	Measured at 60 rpm (1 rps) in Velocity Mode		[7] Loads may be radial and axial such that the sum of the radial and two times the axial does not exceed this figure.			
[4]	Rated for 20,000 Hours or 40,000 Hours @ 155° C (311°F)		[8] Motor shaft is IP30 rated.			

	Motor Size:	APEX610	Value	Units	Tolerance
1	Constant (s):	Torque	61.4 (0.43)	oz-in/A rms (Nm/A rms)	± 10%
2		Voltage (Sinusoidal)	26.2	V rms/Krpm	±10%
3		Electrical Time	13.16	milliseconds	nominal
4		Mechanical Time	0.762	milliseconds	nominal
5		Thermal	21	minutes	nominal
6	Torque (s): (NOTE: Values are with rated and peak current, lines 15 & 16 below. Drive current, and thus torque, may be lower.)	Continuous, Stall	977 (6.90)	oz-in (Nm)	min. [1]
7		Continuous, Stall	921.6 (6.51)	oz-in (Nm)	min. [2]
8		Continuous, Rated	653 (4.61)	oz-in (Nm)	min. [2]
9		Peak, Max w/o Saturation	2630 (18.57)	oz-in (Nm)	min. [1]
10		Static Friction	0.96 (0.007)	oz-in (Nm)	max
11		Ripple (of Rated Torque)	5	percent	min. [3]
12	Speed:	Rated	7000 (117)	rpm (rps)	reference
13		Maximum	7000 (117)	rpm (rps)	reference
14	Frequency	Rated	233	Hz	max.
15	Current:	Rated	15	A rms	max. [1]
16		Peak	45	A rms	nominal
17	Voltage:	Rated	230	V rms	reference
18		Max	250	V rms	maximum
19	Output Power:	Rated	3.3 (4.5)	kWatts (hp)	min. [1]
20	Inductance:	Terminal (line-line)	5	mH	± 30%
21	D.C. Resistance	Terminal (line-line)	0.38	ohms	± 10 % [1]
22	Acceleration at Rated Torque		73934	rads/sec ²	Theoretical
23	Rotor Inertia		13.72 (251.2)	oz-in ² (kgm ² * 1E-6)	nominal
24	Damping		1.728 (0.0122)	oz-in/krpm (Nm/krpm)	nominal
25	Weight		16.35 (7.43)	lbs. (kg)	max.
26	Winding Temperature		170°C (338°F) [4]	°C (°F)	max.
27	Winding Temperature Rise (Above Ambient) [1]		145°C (293°F)	°C (°F)	reference
28	Insulation Class		H	—	reference
29	Thermostat TRIP Temperature		170°C (338°F)	°C (°F)	± 5 °C
30	Thermostat RESET Temperature		135°C (275°F)	°C (°F)	± 10 °C
31	Dielectric Strength, (Winding-to-Frame)		1750	VAC	min.
32	Winding Capacitance-to-Frame		0.00205	µF	max.
33	IP Classification		65 [8]	rated	standard
34	Shaft:	Radial-Play	14E-6 (80E-9)	in/lb (m/N)	reference
		At End At Faceplate	8E-6 (45E-9)	in/lb (m/N)	reference
35	Material [5]		RC #30		
36	Magnet Type		NdFeB		
37	Loading [6]	1000 rpm (17 rps)	93.5 (416)	lbs. (N)	max. [7]
		2000 rpm (33 rps)	74.2 (330)	lbs. (N)	max. [7]
		3000 rpm (50 rps)	64.8 (288)	lbs. (N)	max. [7]
		4000 rpm (67 rps)	59 (262)	lbs. (N)	max. [7]
		5000 rpm (83 rps)	54.7 (243)	lbs. (N)	max. [7]
38	Bearing Class, Internal/External		1/Class 3	ABEC/AFBMA	reference
39	Bearing Grease		SRI #2	Manufacturer	reference
40	Shaft Seal Pressure		3 (0.21)	psi (kg/cm ²)	max.
41	Basic Motor Design		3 phase wye connected 2(P/2)		
42	Stator Phase Sequence		A-C-B (viewed from front face plate)		
43	Vendor/Supplier		Industrial Drives B-206-D		
44	Resolver Type/Accuracy		Single-Speed; Rotor-Excited; ± 10 arc min.		
45	Resolver Manufacturer/Model #		Fasco # 21-BRCX-335-J39		
46	Standard Resolver Cable Part Number		71-013862-xx		
47	Standard Motor Cable Part Number		71-013864-xx		
48	Options:	Brake—24VDC (0.57A)—850 oz-in (6.0 Nm) Holding Torque IP67 Classification Incremental Encoder Tachometer No Keyway			
[1]	25°C (77°F) Ambient		[5] Rotor steel is rated as <i>fatigue proof</i>		
[2]	40°C (104°F) Ambient		[6] Loads centered 1 inch from mounting flange		
[3]	Measured at 60 rpm (1 rps) in Velocity Mode		[7] Loads may be radial and axial such that the sum of the radial and two times the axial does not exceed this figure.		
[4]	Rated for 20,000 Hours or 40,000 Hours @ 155° C (311°F)		[8] Motor shaft is IP30 rated.		

	Motor Size:	APEX620		Value	Units	Tolerance
1	Constant (s):	Torque		124.2 (0.877)	oz-in/A rms (Nm/A rms)	± 10%
2		Voltage (Sinusoidal)		53	V rms/Krpm	± 10%
3		Electrical Time		23.4	milliseconds	nominal
4		Mechanical Time		0.82	milliseconds	nominal
5		Thermal		22	minutes	nominal
6	(NOTE: Values are with rated and peak current, lines 15 & 16 below. Drive current, and thus torque, may be lower.)	Torque (s): Continuous, Stall		1974 (13.94)	oz-in (Nm)	min. [1]
7		Continuous, Stall		1862 (13.15)	oz-in (Nm)	min. [2]
8		Continuous, Rated		1632 (11.52)	oz-in (Nm)	min. [2]
9		Peak, Max w/o Saturation		5299 (37.42)	oz-in (Nm)	min. [1]
10		Static Friction		25 (0.176)	oz-in (Nm)	max.
11		Ripple (of Rated Torque)		4.5	percent	min. [3]
12	Speed:	Rated		3700 (62)	rpm (rps)	reference
13		Maximum		3700 (62)	rpm (rps)	reference
14	Frequency	Rated		123	Hz	max.
15	Current:	Rated		15	A rms	max. [1]
16		Peak		45	A rms	nominal
17	Voltage:	Rated		230	V rms	reference
18		Max		250	V rms	maximum
19	Output Power:	Rated		4.5 (6)	kWatts (hp)	min. [1]
20	Inductance:	Terminal (line-line)		15	mH	± 30%
21	D.C. Resistance	Terminal (line-line)		0.64	Ohms	± 10 % [1]
22	Acceleration at Rated Torque			57025	rads/sec ²	Theoretical
23	Rotor Inertia			35.8 (656)	oz-in ² (kgm ² * 1E-6)	nominal
24	Damping			2.496 (0.0176)	oz-in/krpm (Nm/krpm)	nominal
25	Weight			29 (13.2)	lbs. (kg)	max.
26	Winding Temperature			170°C (338°F) [4]	°C (°F)	max.
27	Winding Temperature Rise (Above Ambient) [1]			145°C (293°F)	°C (°F)	reference
28	Insulation Class			H	—	reference
29	Thermostat TRIP Temperature			170°C (338°F)	°C (°F)	± 5 °C
30	Thermostat RESET Temperature			135°C (275°F)	°C (°F)	± 10 °C
31	Dielectric Strength, (Winding-to-Frame)			1750	VAC	min.
32	Winding Capacitance-to-Frame			0.0034	µF	max.
33	IP Classification			65 [8]	rated	standard
34	Shaft:	Radial-Play	At End	20E-6 (114E-9)	in/lb (m/N)	reference
			At Faceplate	7E-6 (40E-9)	in/lb (m/N)	reference
35		Material [5]		RC-#30	—	—
36		Magnet Type		NdFeB	—	—
37	Loading [6]	1000 rpm (17 rps)		154.7 (688)	lbs. (N)	max. [7]
		2000 rpm (33 rps)		122.8 (546)	lbs. (N)	max. [7]
		3000 rpm (50 rps)		107.2 (477)	lbs. (N)	max. [7]
		4000 rpm (67 rps)		N/A	lbs. (N)	max. [7]
		5000 rpm (83 rps)		N/A	lbs. (N)	max. [7]
38	Bearing Class, Internal/External			1/Class 3	ABEC/AFBMA	reference
39	Bearing Grease			SRI #2	Manufacturer	reference
40	Shaft Seal Pressure			3 (0.21)	psi (kg/cm ²)	max.
41	Basic Motor Design			3 phase wye connected 2(P/2)		
42	Stator Phase Sequence			A-C-B (viewed from front face plate)		
43	Vendor/Supplier			Industrial Drives B-404-D		
44	Resolver Type/Accuracy			Single-Speed; Rotor-Excited; ± 10 arc min.		
45	Resolver Manufacturer/Model #			Fasco # 21-BRCX-335-J39		
46	Standard Resolver Cable Part Number			71-013862-xx		
47	Standard Motor Cable Part Number			71-013864-xx		
48	Options:	Brake—24VDC (0.93A)—1130 oz-in (8.0 Nm) Holding Torque IP67 Classification Incremental Encoder Tachometer No Keyway				

- [1] 25°C (77°F) Ambient
[2] 40°C (104°F) Ambient
[3] Measured at 60 rpm (1 rps) in Velocity Mode
[4] Rated for 20,000 Hours or 40,000 Hours @ 155° C (311°F)

- [5] Rotor steel is rated as *fatigue proof*
[6] Loads centered 1 inch from mounting flange
[7] Loads may be radial and axial such that the sum of the radial and two times the axial does not exceed this figure.
[8] Motor shaft is IP30 rated.

	Motor Size:	APEX630	Value	Units	Tolerance	
1	Constant (s):	Torque	175.3 (1.24)	oz-in/A rms (Nm/A rms)	± 10%	
2		Voltage (Sinusoidal)	74.9	V rms/Krpm	± 10%	
3		Electrical Time	26.7	milliseconds	nominal	
4		Mechanical Time	0.68	milliseconds	nominal	
5		Thermal	28	minutes	nominal	
6	Torque (s):	Continuous, Stall	2788 (19.69)	oz-in (Nm)	min. [1]	
7	(NOTE: Values are with	Continuous, Stall	2630 (18.57)	oz-in (Nm)	min. [2]	
8	rated and peak current,	Continuous, Rated	2304 (16.27)	oz-in (Nm)	min. [2]	
9	lines 15 & 16 below.	Peak, Max w/o Saturation	7488 (52.88)	oz-in (Nm)	min. [1]	
10	Drive current, and thus	Static Friction	40.7 (0.287)	oz-in (Nm)	max.	
11	torque, may be lower.)	Ripple (of Rated Torque)	4.5	percent	min. [3]	
12	Speed:	Rated	2500 (42)	rpm (rps)	reference	
13		Maximum	2500 (42)	rpm (rps)	reference	
14	Frequency	Rated	83	Hz	max.	
15	Current:	Rated	15	A rms	max. [1]	
16		Peak	45	A rms	nominal	
17	Voltage:	Rated	230	V rms	reference	
18		Max	250	V rms	maximum	
19	Output Power:	Rated	4.3 (5.7)	kWatts (hp)	min. [1]	
20	Inductance:	Terminal (line-line)	20	mH	± 30%	
21	D.C. Resistance	Terminal (line-line)	0.75	Ohms	± 10 % [1]	
22	Acceleration at Rated Torque		56934	rads/sec ²	Theoretical	
23	Rotor Inertia		50.7 (929)	oz-in ² (kgm ² * 1E-6)	nominal	
24	Damping		2.88 (0.020)	oz-in/krpm (Nm/krpm)	nominal	
25	Weight		32 (14.5)	lbs. (kg)	max.	
26	Winding Temperature		170°C (338°F) [4]	°C (°F)	max.	
27	Winding Temperature Rise (Above Ambient) [1]		145°C (293°F)	°C (°F)	reference	
28	Insulation Class		H	—	reference	
29	Thermostat TRIP Temperature		170°C (338°F)	°C (°F)	± 5 °C	
30	Thermostat RESET Temperature		135°C (275°F)	°C (°F)	± 5 °C	
31	Dielectric Strength, (Winding-to-Frame)		1750	VAC	min.	
32	Winding Capacitance to Frame		0.0038	µF	max.	
33	IP Classification		65 [8]	rated	standard	
34	Shaft:	Radial-Play	At End	20E-6 (114E-9)	in/lb (m/N)	reference
			At Faceplate	7E-6 (40E-9)	in/lb (m/N)	reference
35		Material [5]		RC-#30	—	—
36		Magnet Type		NdFeB	—	—
37		Loading [6]	1000 rpm (17 rps)	160 (712)	lbs. (N)	max. [7]
			2000 rpm (33 rps)	127.1 (565)	lbs. (N)	max. [7]
			3000 rpm (50 rps)	N/A	lbs. (N)	max. [7]
			4000 rpm (67 rps)	N/A	lbs. (N)	max. [7]
			5000 rpm (83 rps)	N/A	lbs. (N)	max. [7]
38	Bearing Class, Internal/External		1/Class 3	ABEC/AFBMA	reference	
39	Bearing Grease		SRI #2	Manufacturer	reference	
40	Shaft Seal Pressure		3 (0.21)	psi (kg/cm ²)	max.	
41	Basic Motor Design		3 phase wye connected 2(P/2)			
42	Stator Phase Sequence—CW rotor rotation		A-C-B (viewed from front face plate)			
43	Vendor/Supplier		Industrial Drives B-406-D			
44	Resolver Type/Accuracy		Single-Speed; Rotor-Excited: ± 10 arc min.			
45	Resolver Manufacturer/Model #		Fasco # 21-BRCX-335-J39			
46	Standard Resolver Cable Part Number		71-013862-xx			
47	Standard Motor Cable Part Number		71-013864-xx			
48	Options:	Brake—24VDC (0.93A)—1130 oz-in (8.0 Nm) Holding Torque IP67 Classification Incremental Encoder Tachometer No Keyway				
[1]	25°C (77°F) Ambient		[5] Rotor steel is rated as <i>fatigue proof</i>			
[2]	40°C (104°F) Ambient		[6] Loads centered 1 inch from mounting flange			
[3]	Measured at 60 rpm (1 rps) in Velocity Mode		[7] Loads may be radial and axial such that the sum of the radial and two times the axial does not exceed this figure.			
[4]	Rated for 20,000 Hours or 40,000 Hours @ 155°C (311°F)		[8] Motor shaft is IP30 rated.			

	Motor Size	APEX635	Value	Units	Tolerance	
1	Constant (s):	Torque	164.0 (1.154)	oz-in/A rms (Nm/A rms)	± 10%	
2		Voltage (Sinusoidal)	70	V rms/Krpm	± 10%	
3		Electrical Time	0.77	milliseconds	nominal	
4		Mechanical Time	20.8	milliseconds	nominal	
5		Thermal	28	minutes	nominal	
6	Torque (s):	Continuous, Stall	2605 (18.39)	oz-in (Nm)	min. [1]	
7	(NOTE: Values are with rated and peak current, lines 15 & 16 below.	Continuous, Stall	2458 (17.36)	oz-in (Nm)	min. [2]	
8		Continuous, Rated	2054 (14.50)	oz-in (Nm)	min. [2]	
9		Peak, Max w/o Saturation	7008 (49.49)	oz-in (Nm)	min. [1]	
10	Drive current, and thus torque, may be lower.)	Static Friction	69 (0.49)	oz-in (Nm)	max.	
11		Ripple (of Rated Torque)	4.5	percent	min. [3]	
12	Speed:	Rated	3000 (50)	rpm (rps)	reference	
13		Maximum	3000 (50)	rpm (rps)	reference	
14	Frequency	Rated	150	Hz	max.	
15	Current:	Rated	15	A rms	max. [1]	
16		Peak	45	A rms	nominal	
17	Voltage:	Rated	230	V rms	reference	
18		Max	250	V rms	maximum	
19	Output Power:	Rated	4.5 (6.1)	kWatts (hp)	min. [1]	
20	Inductance:	Terminal (line-line)	14	mH	± 30%	
21	D.C. Resistance	Terminal (line-line)	0.647	Ohms	± 10 % [1]	
22	Acceleration at Rated Torque		48945	rads/sec ²	Theoretical	
23	Rotor Inertia		56.1 (1028)	oz-in ² (kgm ² * 1E-6)	nominal	
24	Damping		2.88 (0.020)	oz-in/krpm (Nm/krpm)	nominal	
25	Weight		37 (16.8)	lbs. (kg)	max.	
26	Winding Temperature		170°C (338°F) [4]	°C (°F)	max.	
27	Winding Temperature Rise (Above Ambient) [1]		145°C (293°F)	°C (°F)	reference	
28	Insulation Class		H	—	reference	
29	Thermostat TRIP Temperature		170°C (338°F)	°C (°F)	± 5 °C	
30	Thermostat RESET Temperature		135°C (275°F)	°C (°F)	± 5 °C	
31	Dielectric Strength, (Winding-to-Frame)		1750	VAC	min.	
32	Winding Capacitance to Frame		0.0038	µF	max.	
33	IP Classification		65	rated	standard	
34	Shaft:	Radial-Play	At End At Faceplate	20E-6 (114E-9) 7E-6 (40E-9)	in/lb (m/N) in/lb (m/N)	reference reference
35		Material [5]		RC-#30		
36		Magnet Type		NdFeB		
37		Loading [6]	1000 rpm (17 rps) 2000 rpm (33 rps) 3000 rpm (50 rps) 4000 rpm (67 rps) 5000 rpm (83 rps)	243.5 (1,083) 193.3 (860) 168.8 (751) N/A N/A	lbs. (N) lbs. (N) lbs. (N) lbs. (N) lbs. (N)	max. [7] max. [7] max. [7] max. [7] max. [7]
38	Bearing Class, Internal/External		1/Class 3	ABEC/AFBMA	reference	
39	Bearing Grease		SFI #2	Manufacturer	reference	
40	Shaft Seal Pressure		3 (0.21)	psi (kg/cm ²)	max.	
41	Basic Motor Design		3 phase wye connected 3(P/2)			
42	Stator Phase Sequence—CW rotor rotation		A-C-B (viewed from front face plate)			
43	Vendor/Supplier		Industrial Drives B-602-C			
44	Resolver Type/Accuracy		Single-Speed; Rotor-Excited; ± 10 arc min.			
45	Resolver Manufacturer/Model #		Fasco # 21-BRCX-335-J39			
46	Standard Resolver Cable Part Number		71-013862-xx			
47	Standard Motor Cable Part Number		71-013865-xx			
48	Options:	Brake—24VDC (0.93A)— 1130 oz-in(8.0 Nm) Holding Torque IP67 Classification Incremental Encoder Tachometer No Keyway				
[1]	25°C (77°F) Ambient		[5] Rotor steel is rated as <i>fatigue proof</i>			
[2]	40°C (104°F) Ambient		[6] Loads centered 1 inch from mounting flange			
[3]	Measured at 60 rpm (1 rps) in Velocity Mode		[7] Loads may be radial and axial such that the sum of the radial and two times the axial does not exceed this figure.			
[4]	Rated for 20,000 Hours or 40,000 Hours @ 155° C (311°F)		[8] Motor shaft is IP30 rated.			

APEX635 Motor Specifications

	Motor Size:	APEX640	Value	Units	Tolerance	
1	Constant (s):	Torque	291.5 (2.06)	oz-in/A rms (Nm/A rms)	± 10%	
2		Voltage (Sinusoidal)	124.5	V rms/Krpm	± 10%	
3		Electrical Time	26.2	milliseconds	nominal	
4		Mechanical Time	0.55	milliseconds	nominal	
5		Thermal	33	minutes	nominal	
6	Torque (s):	Continuous, Stall	4640 (32.76)	oz-in (Nm)	min. [1]	
7	(NOTE: Values are with rated and peak current, lines 15 & 16 below.	Continuous, Stall	4378 (30.92)	oz-in (Nm)	min. [2]	
8		Continuous, Rated	3955 (27.93)	oz-in (Nm)	min. [2]	
9		Peak, Max w/o Saturation	12461 (87.99)	oz-in (Nm)	min. [1]	
10	Drive current, and thus torque, may be lower.)	Static Friction	73 (0.52)	oz-in (Nm)	max.	
11		Ripple (of Rated Torque)	4.5	percent	max. [3]	
12	Speed:	Rated	1600 (27)	rpm (rps)	reference	
13		Maximum	1600 (27)	rpm (rps)	reference	
14	Frequency	Rated	80	Hz	max.	
15	Current:	Rated	15	A rms	max. [1]	
16		Peak	45	A rms	nominal	
17	Voltage:	Rated	230	V rms	reference	
18		Max	250	V rms	maximum	
19	Output Power:	Rated	4.7 (6.3)	kWatts (hp)	min. [1]	
20	Inductance:	Terminal (line-line)	20	mH	± 30%	
21	D.C. Resistance	Terminal (line-line)	0.763	Ohms	± 10% [1]	
22	Acceleration at Rated Torque		43667	rads/sec ²	Theoretical	
23	Rotor Inertia		111.0 (2034)	oz-in ² (kgm ² * 1E-6)	nominal	
24	Damping		15.36 (0.1085)	oz-in/krpm (Nm/krpm)	nominal	
25	Weight		51 (23.2)	lbs. (kg)	max.	
26	Winding Temperature		170°C (338°F) [4]	°C (°F)	max.	
27	Winding Temperature Rise (Above Ambient) [1]		145°C (293°F)	°C (°F)	reference	
28	Insulation Class		H	—	reference	
29	Thermostat TRIP Temperature		170°C (338°F)	°C (°F)	± 5 °C	
30	Thermostat RESET Temperature		135°C (275°F)	°C (°F)	± 10 °C	
31	Dielectric Strength, (Winding-to-Frame)		1750	VAC	min.	
32	Winding Capacitance to Frame		0.0082	µF	max.	
33	IP Classification		65 [8]	rated	standard	
34	Shaft:	Radial-Play	At End	10E-6 (57E-9)	in/lb (m/N)	reference
			At Faceplate	4E-6 (23E-9)	in/lb (m/N)	reference
35		Material [5]	RC-#30	—	—	
36		Magnet Type	NdFeB	—	—	
37		Loading [6]	1000 rpm (17 rps)	255.6 (1,130)	lbs. (N)	max. [7]
			2000 rpm (33 rps)	N/A	lbs. (N)	max. [7]
			3000 rpm (50 rps)	N/A	lbs. (N)	max. [7]
			4000 rpm (67 rps)	N/A	lbs. (N)	max. [7]
			5000 rpm (83 rps)	N/A	lbs. (N)	max. [7]
38	Bearing Class, Internal/External		1/Class 3	ABEC/AFBMA	reference	
39	Bearing Grease		SRI #2	Manufacturer	reference	
40	Shaft Seal Pressure		3 (0.21)	psi (kg/cm ²)	max.	
41	Basic Motor Design		3 phase wye connected 3(P/2)			
42	Stator Phase Sequence—CW rotor rotation		A-C-B (viewed from front face plate)			
43	Vendor/Supplier		Industrial Drives B-604-D			
44	Resolver Type/Accuracy		Single-Speed; Rotor-Excited; ± 10 arc min.			
45	Resolver Manufacturer/Model #		Fasco # 21-BRCX-335-J39			
46	Standard Resolver Cable Part Number		71-013862-xx			
47	Standard Motor Cable Part Number		71-013865-xx			
48	Options:	Brake—24VDC (1.27A)—6800 oz-in (48 Nm) Holding Torque IP67 Classification Incremental Encoder Tachometer No Keyway				

- [1] 25°C (77°F) Ambient
[2] 40°C (104°F) Ambient
[3] Measured at 60 rpm (1 rps) in Velocity Mode
[4] Rated for 20,000 Hours or 40,000 Hours
@ 155° C (311°F)

- [5] Rotor steel is rated as *fatigue proof*
[6] Loads centered 1 inch from mounting flange
[7] Loads may be radial and axial such that the sum of the radial and two times the axial does not exceed this figure.
[8] Motor shaft is IP30 rated.

APEX640 Motor Specifications

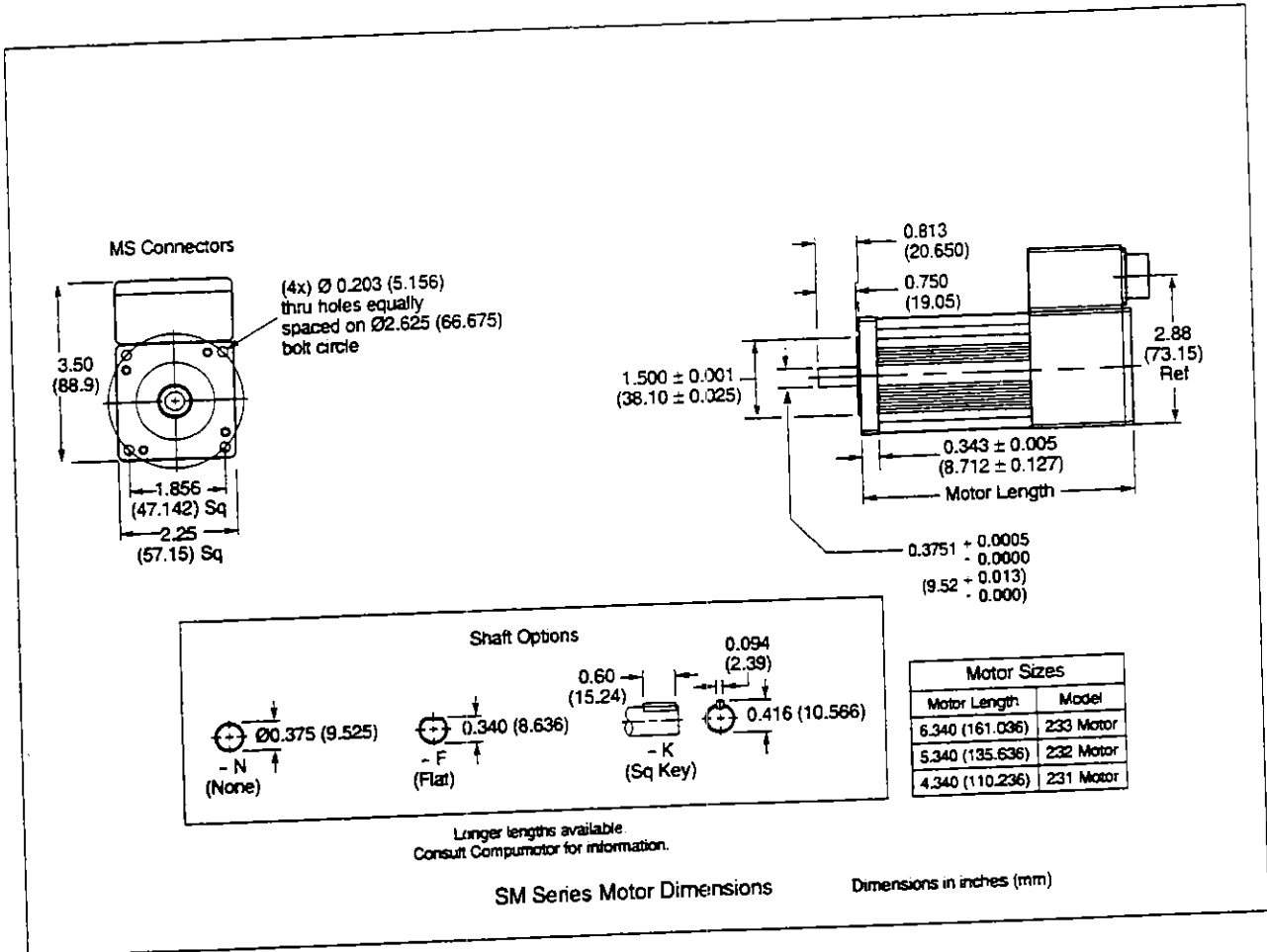

SM231, SM232 & SM233 Motor Dimensions

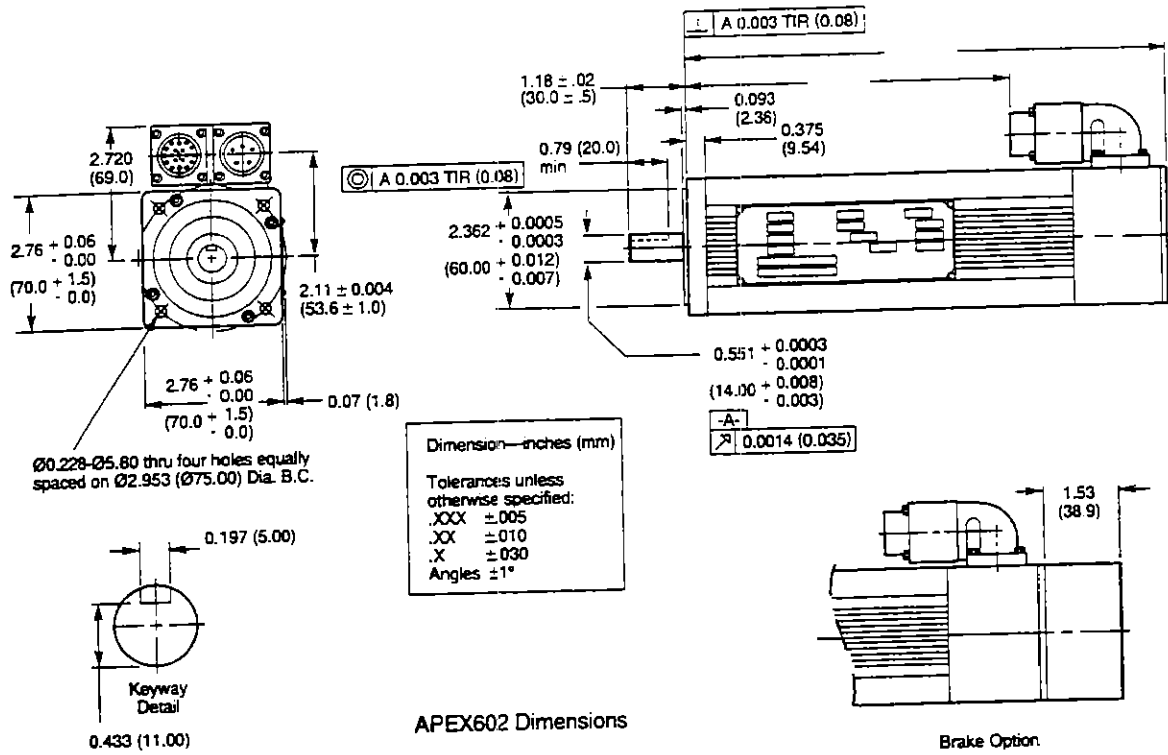

APEX602 Dimensions

APEX602 Motor Dimensions

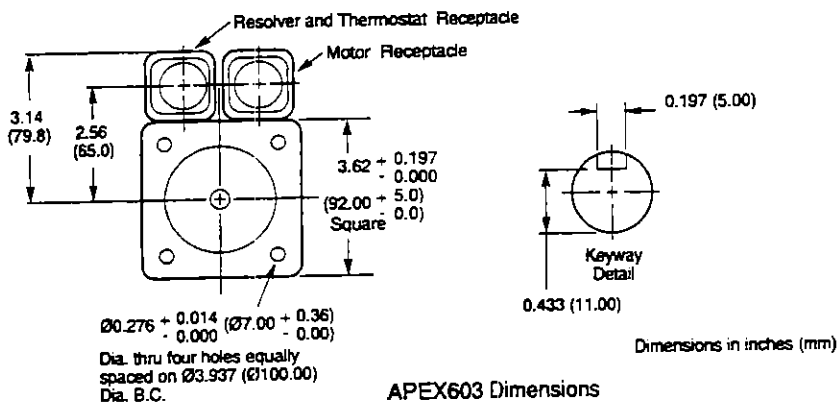
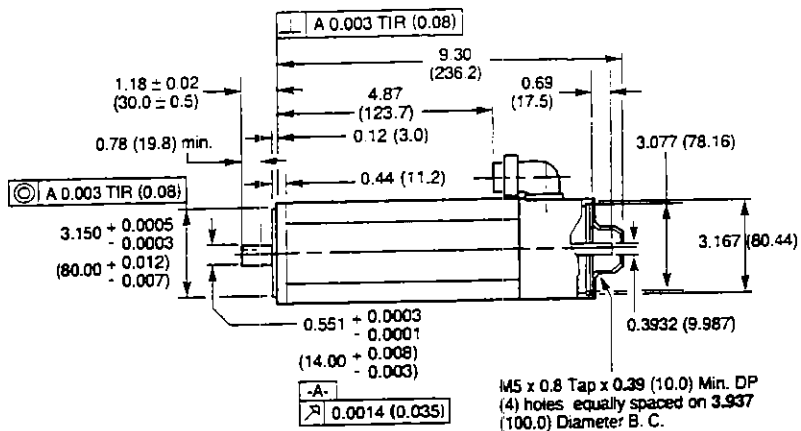

APEX603 Motor Dimensions

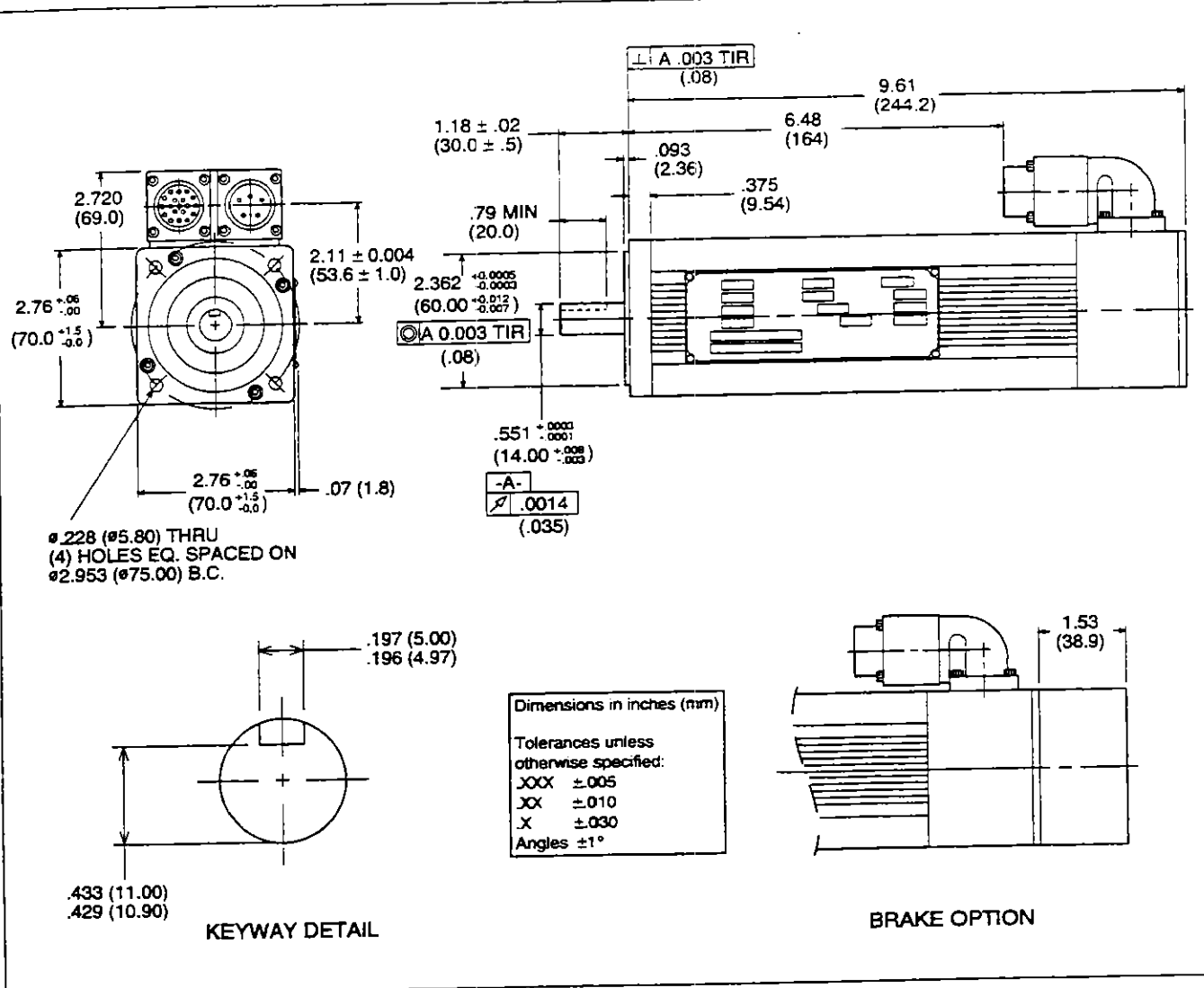

$\text{A } 0.003 \text{ TIR}$ (.08)
 $\text{A } 0.003 \text{ TIR}$ (.08)

APEX604 Motor Dimensions

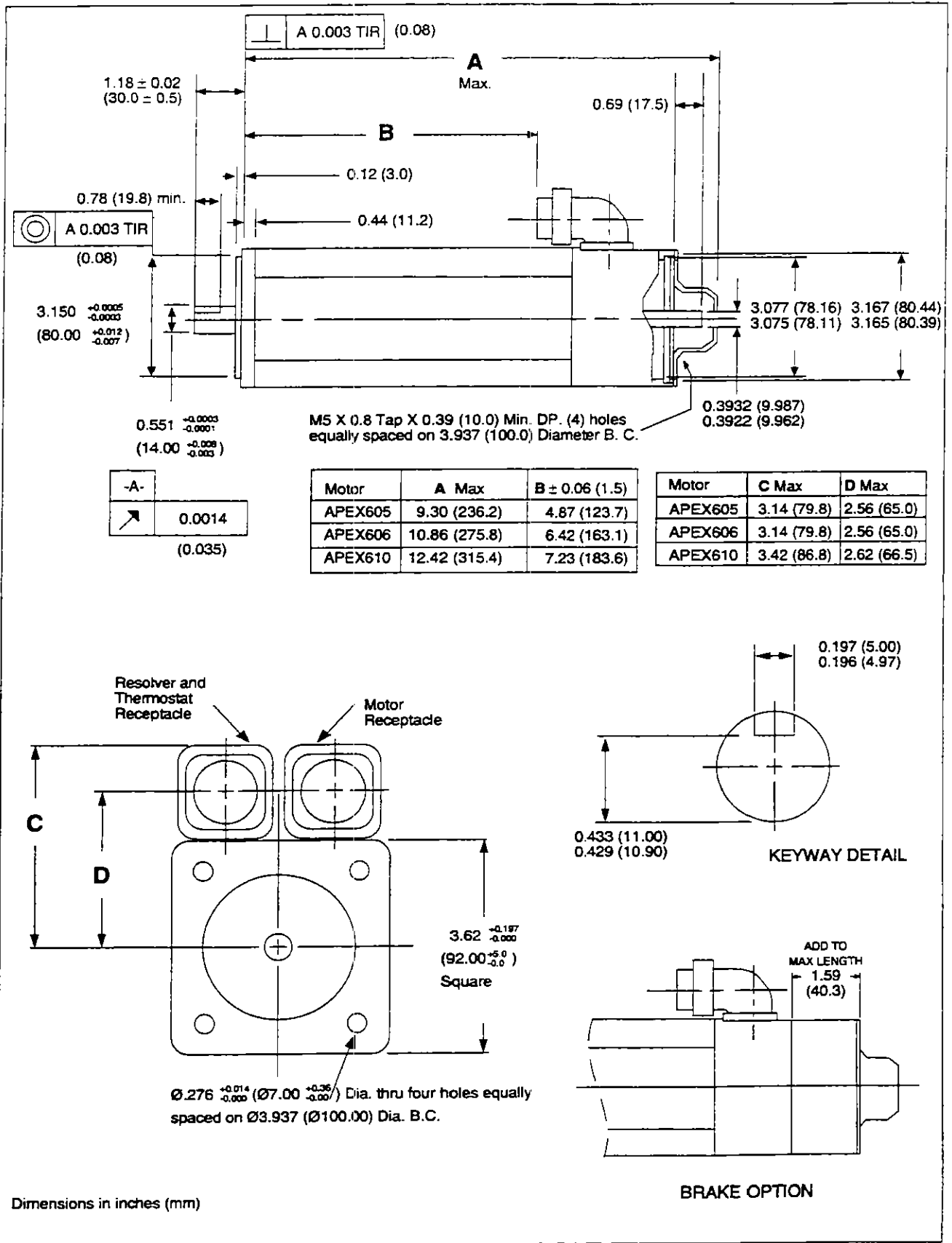

APEX605, APEX606, APEX610 Motor Dimensions

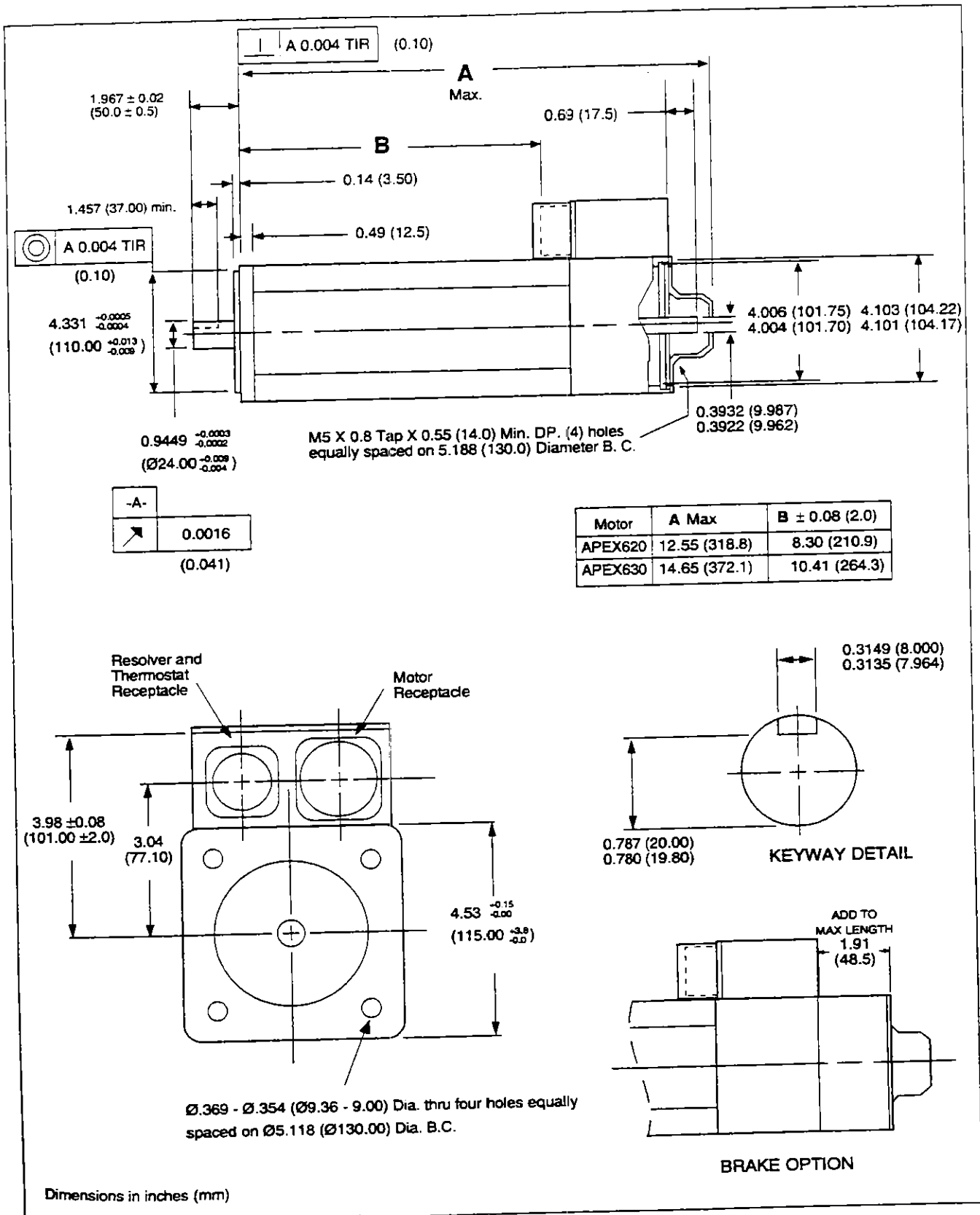

APEX620 & APEX630 Motor Dimensions

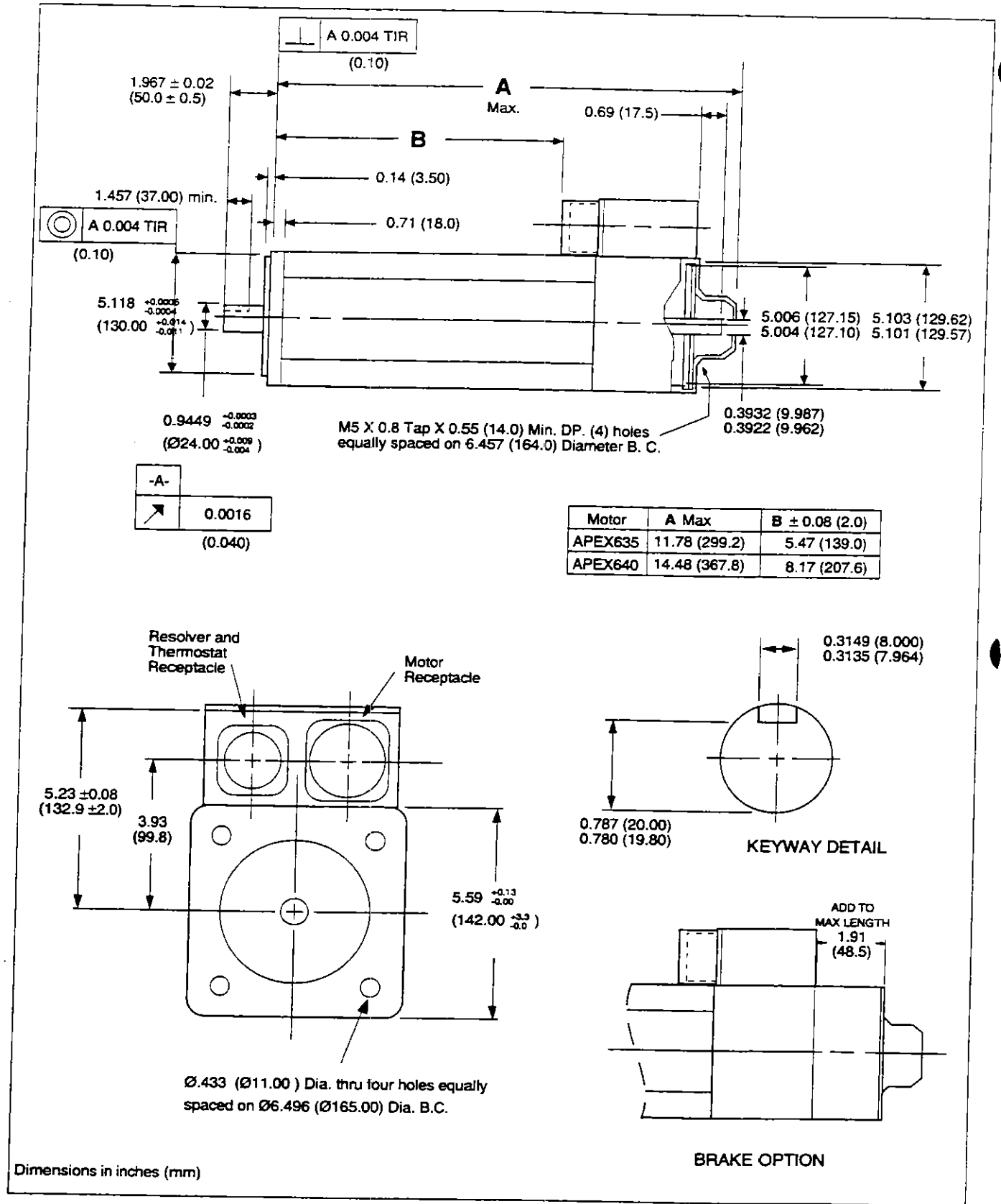

APEX635 & APEX640 Motor Dimensions