

Linearserv Speed/Force Curves

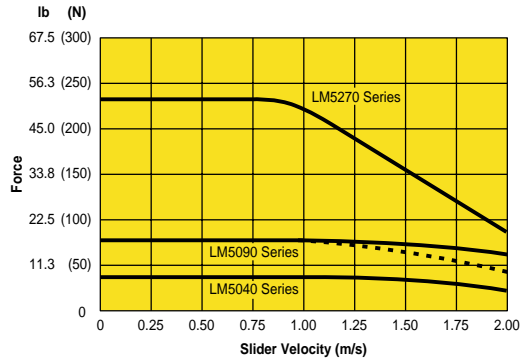
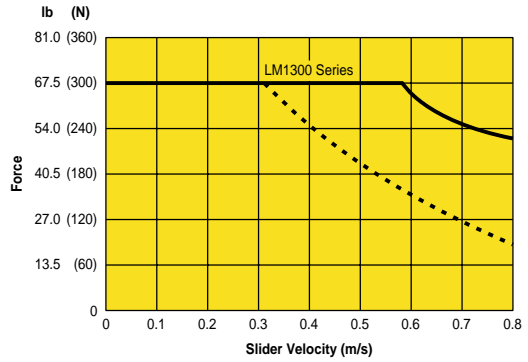
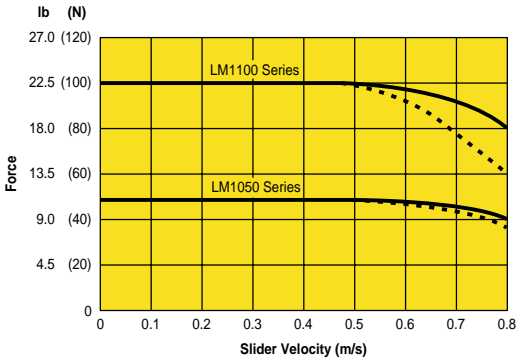

----- 110 ~ 115 V AC power supply ——— 200 ~ 230 V AC power supply

Head Amplifier

Dimensions in inches (mm)

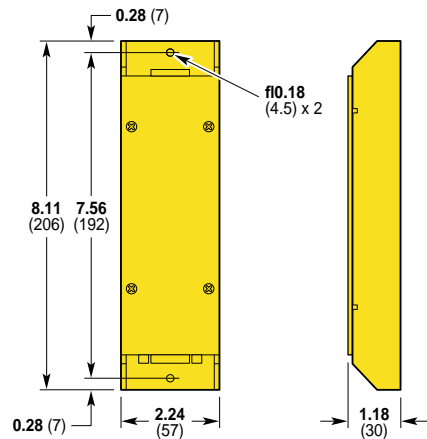

The speed/force curves represent peak force available; continuous forces are approximately 2/3 of the peak force value.

Drive Dimensions

Dimensions in inches (mm)

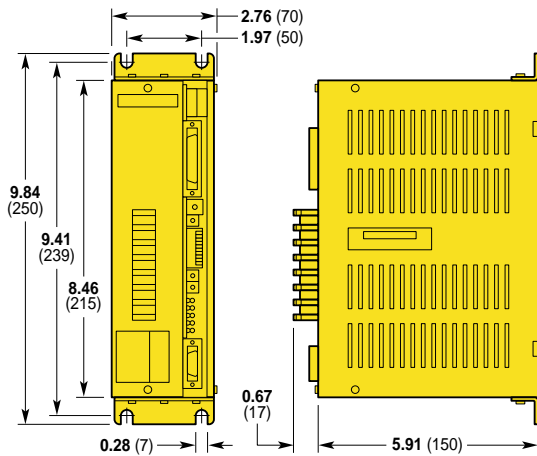

Cable Option #1

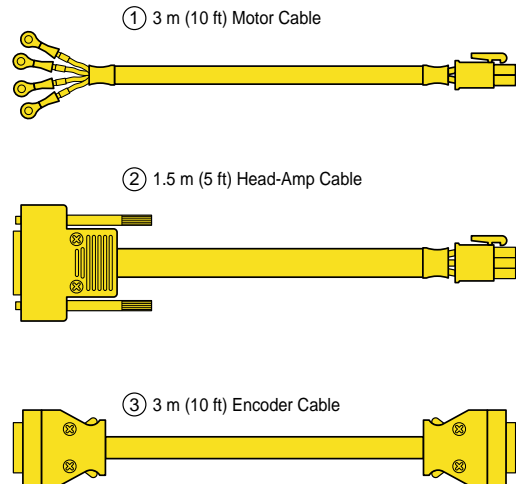

Drives & Drive/Controllers

controllers
drives
motors