



Digital Servo Drive for Direct-Drive Motors

The Dynaserv is a family of direct-drive servo systems for industrial and high-tech applications. Direct-drive systems are integrated positioning systems that allow the elimination of mechanical transmissions and allow the load to be mounted directly to the motor. This creates an extremely high-performance system that can simplify and increase the performance of many machine types. The Dynaserv G3 is the latest generation drive of the Dynaserv family and provides optimal control of a direct-drive system.

The G3 is an all-new digital drive with implementation of the advanced control and filtering algorithms needed to control a direct-drive motor. The G3 can operate in torque, velocity, or position control modes. The G3 comes with a modern Windows-based software utility that makes the set-up of the Dynaserv system easy and fast via RS232 or RS485 communication. When operated in position mode, the Dynaserv has an auto-tune utility that allows quick and easy setting of the tuning parameters. Digital implementation of the low pass and notch filtering makes mechanical resonance abatement far easier than in earlier models.

Simple motion control functions can be obtained without an external controller. The G3 contains a motion table that allows the storage of indexing moves that can be initiated through a serial command or commanded via discrete inputs. When used with a PLC using multiple inputs, the G3 can be used to achieve high-performance motion and handle complex tasks.

The Dynaserv is UL recognized and meets the requirements for CE certification. The G3 has additional innovative safety features such as a controlled stop after power failure and a servo disable switch on the front panel of the drive. Since the Dynaserv motor is capable of handling very large loads, the G3 has special circuitry to monitor power regeneration to the drive.

The G3 is a very flexible design allowing operation of the all the DM series motor models and the standard DR series motors. The G3 is also compatible with the Linearserv linear motor system.

Features Performance

- High resolution – up to 4,096,000 pulses/rev, four times the resolution of previous model
- Advanced control and filtering designed for direct drive
- Low pass, notch and velocity loop filters
- Small footprint

Safety and Standard

- Reduction of unexpected move at power failure
- Regeneration power monitoring
- UL, CE
- Servo disable switch on front panel

Operation

- Operation display panel (optional) for diagnostic information and parameter changes
- Windows utility software

Easy to Use

- Operates in position, velocity or torque modes
- Auto-tuning function
- Built-in index move capability
- User-configurable I/O
- RS232C/485 interface
- Screwless terminal strip connections
- Error/alarm history log
- Motorless operation for easy set-up and configuration of the drive

Specifications

	500W Class	2kW Class
Power Power Supply Control Max. Consumption	100~115VAC / 200~230VAC +10%/-15% 100~115VAC / 200~230VAC +10%/-15% 1.3kVA	50 / 60 Hz single phase 50 / 60 Hz single phase 3.4kVA
Environment Temperature Humidity Atmosphere	0~ +50 (operation) / -20~ +85 (storage) 20~90%RH no condensing (operation and storage) No corrosive gases, dust-free atmosphere. Do not operate in locations exceeding 1000 m above sea level	
Construction Installation Fan Regen. Resistor	Panel mount NA External Built-in DC fan Built-in	
Ext. Dimensions	60 W x 195 H x 150 D (mm)	100 W x 195 H x 200 D (mm)
Weight	1.2kg	2.5kg
Conformed Stand.	Low voltage (declaration)	EN50178 (declaration) EN55011 class A group 1, EN61800-3
Resistance & Pressure	Insulation resistance: 10 M Ω or more (DC500V) Insulation pressure: 1500VAC 1 min	
Encoder Resolution	Dynaserv DMG31XXXA: 4,096,000 pulse/rev (1,024,000 pulse/rev) DMG31XXXB: 2,621,440 pulse/rev (655,360 pulse/rev) DMG31XXXC: 2,621,440 pulse/rev (655,360 pulse/rev) DRG31XXXA: 1,638,400 pulse/rev (819,200 pulse/rev) DRG31XXXB: 1,015,808 pulse/rev (507,904 pulse/rev) DRG31XXXE: 1,228,800 pulse/rev (614,400 pulse/rev) DRG35XXXB: 557,056 pulse/rev (278,528 pulse/rev) DRG35XXXC: 425,984 pulse/rev (212,992 pulse/rev)	
Serial Interface	Communication Communication speed Multi-channel (RS485)	Start-stop system, binary communication 38,400bps Maximum 10 channels
Controller Interface	Pos. command pulse (input) 5V TTL Pos. monitor pulse (output) 5V TTL Contact I/O Analog input ±10 or ± 6	[PLS-SIGN (STEP-DIR)], [UP-DOWN], [A-B encoder] [UP-DOWN], [A-B encoder] 5V TTL 12 for input, 6 for output (with user-configurable function) 5V (12V to 24V as custom) Velocity, Torque/thrust command Torque/thrust limit, torque/thrust feed forward
Mechanical Input Signal	Home sensor, end or travel (EOT)	
Control Section Pos. Control Velocity Control Feed Forward Filter	I-PD control, PID control Proportional control, PID control Position, velocity and acceleration Velocity command, velocity feedback, phase delay compensation and notch (2ch) filters	
Operation Functions	Homing, test, auto-tuning, positioning and jog move functions	
Protection Functions	Encoder error, over voltage, over current, low bus line power voltage, power failure, over load, Regen. error detection, over speed, excessive pos.deviation, hardware EOT and software EOT (for linear coordinate)	
Monitor	Velocity, current instruction, analog (2ch) and digital (2ch)	
Operation/Display	Operation display panel (optional) Operation display pedant (optional) Utility software	
Miscellaneous	Servo deceleration function at power failure (immediate stop) Dynamic brake (as custom)	

DR Specifications

	DR1XXXA	DR1XXXB	DR1XXXE	DR5XXXE	DR5XXXB	DR5XXXC
Repeatability arc-sec	±3	±3	±3	±4	±5	±5
Accuracy arc-sec	±30	±45	±45	±90	±90	±150

DR Series Motor Data

		Model 1008B	Model 1015B	Model 1045B	Model 1070E	Model 1130E	Model 1100A	Model 1200A	Model 1400A
Peak torque	ft-lbs	6	11	33	52	96	74	148	295
	(Nm)	(8)	(15)	(45)	(70)	(130)	(100)	(200)	(400)
Rated torque	ft-lbs	2.2	3.7	11	16.9	31.7	24.3	49.4	98
	(Nm)	(3)	(5)	(15)	(23)	(43)	(33)	(67)	(133)
Rated speed, 115/230VAC	rps	2.0/2.0	2.0/2.0	1.0/2.0	1.5/2.0	0.5/1.0	1.0/1.0	0.5/1.0	0.25/0.5
Maximum power consumption	KVA	0.7	1.0	1.8	2.0	2.5	2.5	3.0	3.2
Rotor inertia	oz-in ² x 10 ²	7.9	11	14	46	68	109	156	219
	(Kgm ² x 10 ⁻³)	(15)	(21)	(26)	(85)	(125)	(200)	(285)	(400)
Max resolution		507,904	507,904	507,904	614,400	614,400	819,200	819,200	819,200
Motor weight	lbs	13	20	29	49	70	68	101	150
	(kg)	(6)	(9)	(13)	(22)	(32)	(31)	(46)	(68)
Maximum static axial load* • Compression • Tension	lbs	6,744	6,744	6,744	8,992	8,992	8,992	8,992	8,992
	lbs	2,248	2,248	2,248	4,496	4,496	4,496	4,496	4,496
Maximum static overhung load*	ft-lb	148	148	148	295	295	295	295	295

DR5000 Series-Motor Data

		Model 5005C	Model 5015C	Model 5030B	Model 5070B
Peak torque	ft-lbs	2.8	10.3	22	52
	(Nm)	(3.8)	(14)	(30)	(70)
Rated speed	rps	6	6	4	4
Rotor inertia	oz-in ² x10 ²	3.28	4.37	4.4	19.7
	(kgm ²)x10 ⁻³	(0.006)	(0.008)	(8)	(36)
Resolution	Steps/rev	212,992	212,992	278,528	278,528
Motor weight	lbs	11.0	15.4	15.4	38.5
	(kg)	(5.0)	(7.0)	(7.0)	(17.5)
Rated torque	ft-lbs	1.4	3.7	7.3	16.9
	(Nm)	(2)	(5)	(10)	(23)
Maximum static axial load* • Compression • Tension	lbs	1124	1124	6600	6600
	lbs	674	674	2200	2200
Maximum static overhung load*	ft-lb	15	15	148	148
Maximum power	KVA	1.0	1.0	3.6	3.6

* When designing a system, de-rate the maximum load to the values shown below:

Application	De-rate Factor
Smooth, rotary motion	1/3
Intermittent press loading	1/5
Repetitive shock loading	1/10



DM Series – Motor Data

		Model 1015B	Model 1030B	Model 1045B	Model 1050A	Model 1100A	Model 1150A	Model 1200A
Peak torque	ft-lbs	11	22	33	37	74	111	148
	(Nm)	(15)	(30)	(45)	(50)	(100)	(150)	(200)
Rated speed • rps	115VAC	2.0	2.0	1.0	1.0	1.0	0.5	0.5
	230VAC	2.0	2.0	2.0	1.0	1.0	1.0	1.0
Rotor inertia	oz-in ² x 10 ²	6.6	8.2	10.4	52.5	65.1	77.6	91.3
	(Kgm ²) x 10 ⁻³	(12)	(15)	(19)	(96)	(119)	(142)	(167)
Maximum steps/rev		655,360	655,360	655,360	1,024,000	1,024,000	1,024,000	1,024,000
Motor weight*	lbs	12	17	21	32	42	53	64
	(kg)	(5.5)	(7.5)	(9.5)	(14.5)	(19)	(24)	(29)
Maximum static axial load** • Compression • Tension	lbs	6,600	6,600	6,600	8,800	8,800	8,800	8,800
	lbs	2,200	2,200	2,200	4,400	4,400	4,400	4,400
Max. static overhung load**	ft-lbs	148	148	148	296	296	296	296
Max. power consumption	KVA	1.6	2.0	2.0	2.4	2.7	3.0	3.0

* Drive weight is 13.2 lbs (6 kgs)

** When designing a system, de-rate the maximum load to the values shown at right:

Application	De-rate Factor
Smooth, rotary motion	1/3
Intermittent press loading	1/5
Repetitive shock loading	1/10

DM1004 Motor Data Specifications

		DM1004B	DM1004C
Peak torque	ft-lbs	3	3
	(N-m)	(4)	(4)
Rated speed • rps	115VAC	2.5	2.5
	230VAC	2.5	2.5
Rotor inertia	oz-in ² x 10 ²	3.01	1.37
	(Kgm ²) x 10 ⁻³	(5.5)	(2.5)
Maximum step	s/rev	655,360	655,360
Motor weight*	lbs	6.6	6.6
	(kg)	(3)	(3)
Maximum static axial load** • Compression • Tension	lbs (kg)	11.25 (5.1)	11.25 (5.1)
	lbs (kg)	11.25 (5.1)	11.25 (5.1)
Maximum power consumption	KVA	0.3	0.3

* Drive weight is 4 lbs (1.8 kgs)

** When designing a system, de-rate the maximum load to the values specified at right:

Application	De-rate Factor
Smooth, rotary motion	1/3
Intermittent press loading	1/5
Repetitive shock loading	1/10

External Dimensions (mm)

500W Class

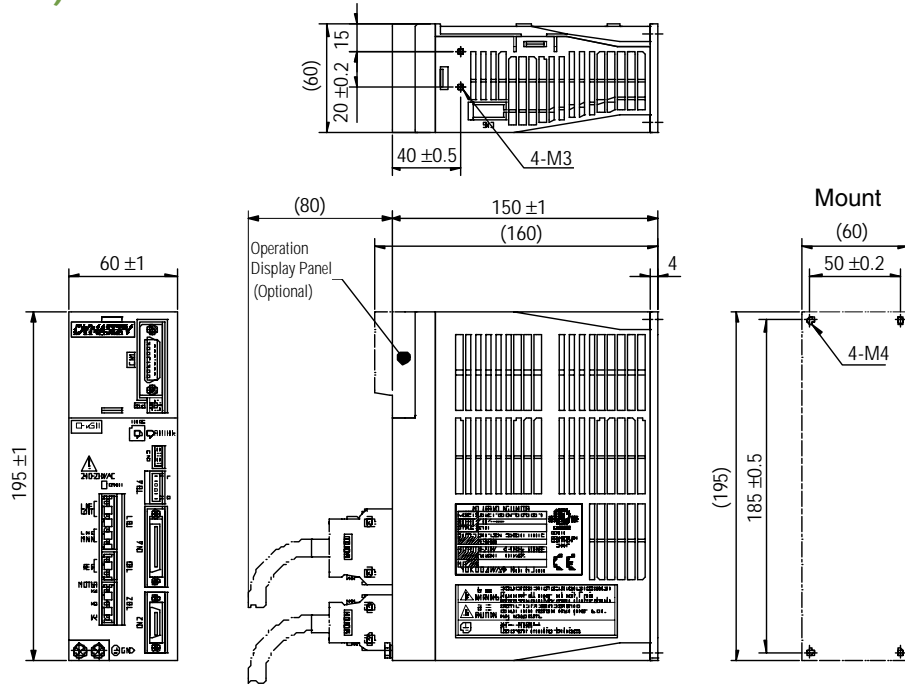

2kW Class

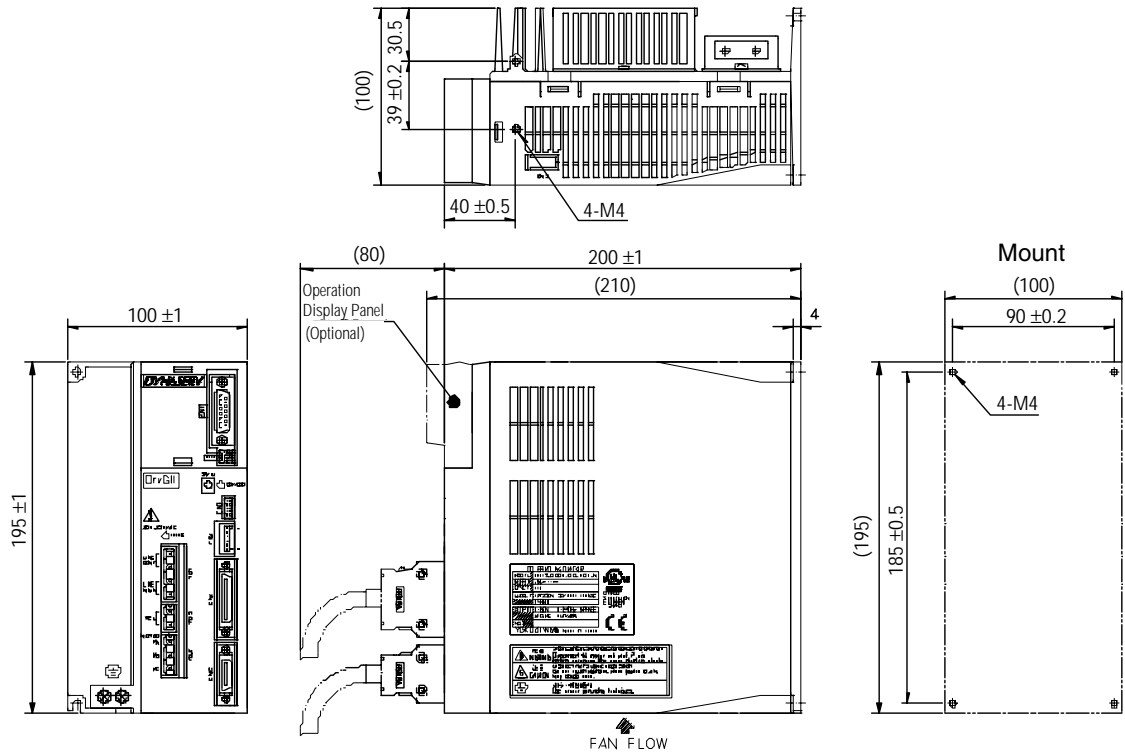

Operation Display Panel (Optional)

G3-Panel

This optional display panel offers the ability to display and set various parameters, and display alarms. Connect to CN1 on the drive

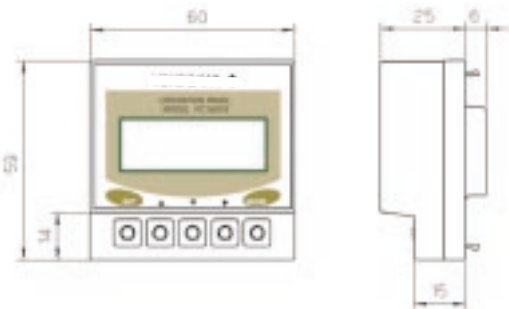

Connectors & Terminals

Number	Item	Connector Part Number	Description	Remark
Power Section				
TB1	Power supply terminal	Connector: 231-204/026-000 (WAGO)	For main & control power supply	Standard
TB2	Motor terminal	Connector: 231-203/026-000 (WAGO)	For motor power cable	Standard
TB3	Regen. resistance terminal	Connector: 231-202/026-000 (WAGO)	For regeneration resistor	Standard
GND	GND terminal	M4 solderless terminal	Protection ground	
Control Section				
TB4	Sensor terminal	Connector: 733-106 (WAGO)	For home sensor ± EOT	Standard
CN1	Serial interface connector (RS232C/485)	Connector: DA-15PF-N (Hirose) Cover: DA-C8-J10-F4-1	For operation display panel, operation display pendant & PC	Optional
CN2	Encoder/resolver connector (RS232C/485)	Connector: PCR-S20F (Honda) Cover: PCR-LS20LA1	For encoder and resolver cable	Optional
CN3	Analog monitor connector	Monitor card G3-R7041WC	For monitors & oscilloscope	Optional
CN4	Controller interface connector	Connector: PCR-S36FS (Honda) Cover: PCR-LS36LA	For connection to PLC	Optional

TB1: Power Supply Terminal

Pin No.	Signal	Definition
1	LINE (CONT) L	AC input for control circuit
2	LINE (CONT) N	AC input for control circuit
3	LINE (MAIN) L	AC input for main power
4	LINE (MAIN) N	AC input for main power

TB2: Motor Terminal

Pin No.	Signal	Definition
1	VA	Output of phase A of motor
2	VB	Output of phase B of motor
3	VC	Output of phase C of motor

TB3: Regeneration Resistance Terminal

Pin No.	Signal	Definition
1	RES +	Regeneration resistance +
2	RES -	Regeneration resistance -

Sensor Input Specifications

Rated voltage	12 - 24VDC (± 10%)
Rated input current	4.1mA/point (at 12VDC) 8.5mA/point (at 24VDC)
Input impedance	3.0k Ohms
Operating voltage (for COMPO)	3.0VDC when power is OFF 9.0VDC when power is ON
Allowable leakage current	To be off at less than 1.0mA

TB4: Sensor Terminal

Pin No.	Signal	Definition
1	COMPO	Sensor power
2	XORG	Home input B-contact
3	XOTD	- EOT input B-contact
4	XOTU	+ EOT input B-contact
5	ERR +	Regeneration error output +
6	ERR -	Regeneration error output -

Regeneration Error Output

Max. working voltage	30VDC
Max. output current	50mA

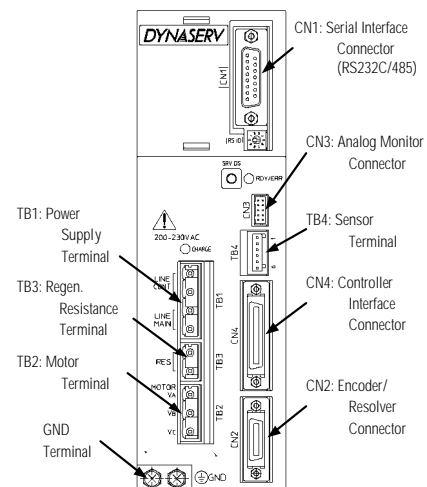

CN1: Serial Interface Connector

Pin	Signal	Definition
1	FG	Frame GND signal (shield)
2	RxD	RxD terminal RS232C single-channel comm.
3	TxD	TxD terminal RS232C single-channel comm.
4	A	Rx (+) side terminal RS485 multi-channel comm.
5	Y	Tx (+) side terminal RS485 multi-channel comm.
6	485SW	Busy condition bit RS485 multi-channel comm.
7	TRMP	Terminator terminal RS485 multi-channel comm. (short circuit to #14 TRMN)
8	CN1SW	Busy condition bit CN1
9	+5V	+5V power (operation display panel and pendant) Do not connect in RS232C/485 communication
10	SG	Signal GND terminal
11	B	Rx (-) side terminal RS485 multi-channel comm.
12	Z	Tx (-) side terminal RS485 multi-channel comm.
13	SG	Signal GND terminal
14	TRMN	Terminator terminal RS485 multi-channel comm. (short circuit to #7 TRMP)
15	SG	Signal GND terminal

CN4: Controller Interface Connector

Pin	Signal	Definition
1	COMP1	Interface power supply
2	COMPN1	Interface power supply
3	DO_0	I/O output
4	DO_1	I/O output
5	DO_2	I/O output
6	DO_3	I/O output
7	DO_4	I/O output
8	DO_5	I/O output
9	UA_OUT+	Position present pulse 1+
10	UA_OUT-	Position present pulse 1-
11	DB_OUT+	Position present pulse 2+
12	DB_OUT-	Position present pulse 2-
13	Z_OUT+	Z-pulse
14	Z_OUT-	Z-pulse
15	PUA_IN+	Position command pulse 1+
16	PUA_IN-	Position command pulse 1-
17	SDB_IN+	Position command pulse 1+
18	SDB_IN-	Position command pulse 1-
19	DI_0	I/O input
20	DI_1	I/O input
21	DI_2	I/O input
22	DI_3	I/O input
23	DI_4	I/O input
24	DI_5	I/O input
25	DI_6	I/O input
26	DI_7	I/O input
27	DI_8	I/O input
28	DI_9	I/O input
29	DI_10	I/O input
30	DI_11	I/O input
31	(NC)	
32	(NC)	
33	ASUB_IN+	Analog sub (auxiliary input)
34	ASUB_IN-	Analog sub (auxiliary input)
35	ACMD_IN+	Analog command input
36	ACMD_IN-	Analog command input
Shield		Shield treatment terminal

CN2: Encoder/Resolver Connector

Pin	Signal		
	Type DM1B-004/006 Type CM1C-004	Type DM (excl. left-hand side models)	Type DR
1	+10V	+10V	-
2	-	-	+S0
3	SIG 0	SIG 0	-
4	-	ECLK+(10V)	-
5	SIG 1	SIG 1	-
6	-	-	-S0
7	ECLK+(3V)	-	-
8	-	-	-C0
9	-	ZERO+	-
10	-	-	+C0
11	-	-	+S180
12	GND	GND	-
13	-	ECLK-(10V)	-
14	GND	GND	-
15	-	-	-S180
16	GND	GND	-
17	-	-	-C180
18	ECLK-(3V)	-	-
19	-	ZERO-	-
20	-	-	+C180
case	Shielding wire	Shielding wire	FG/Shielding wire

CN3: Analog Monitor Connector

Pin	Signal	Definition
1	VEL	Velocity monitor terminal
2	AMON1	Analog monitor terminal 1 (general purpose monitor)
3	AMON2	Analog monitor terminal 2 (general purpose monitor)
4	DMON1	Digital monitor terminal 1 (general purpose monitor)
5	DMON2	Digital monitor terminal 2 (general purpose monitor)
6	TR	Current command
7	TT	Reserved
8	T6	Reserved
9	<prohibited>	Reserved – do not connect any line
10	GND	GND terminal for monitor

How to Order Dynaserv G3

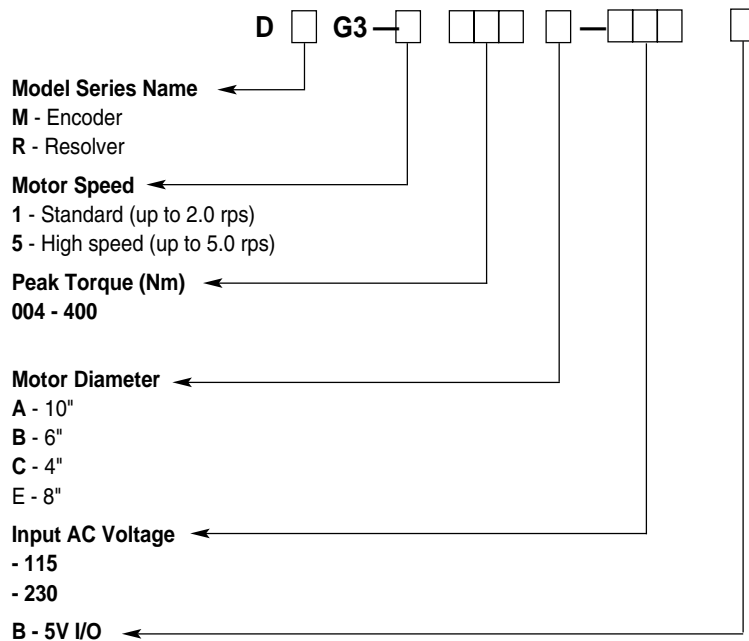

Accessories

Part Number	Description
G3-Panel	Display panel
71-025183-06	Comm cable
71-023715-XX	ACR to G3
71-023716-XX	6K to G3
G3-R7041WC	Analog monitor board
71-025063-XX	6K to G3 with leads for drive I/O