

Contents

Synchronous servo motors manufactured by Parker Hannifin, Electromechanical Division.....	4
Standard servo motors of the HJ range.....	5
Options	6
Motor overview of HJ – motors	7
Dimensional drawings.....	8
HJ96C6-44S	8
HJ116C6-64S / HJ116E6-88S	8
HJ155A8-88S / HJ155E8-130S / HJ155G8-135S.....	8
HJ155G8-135S with fan.....	9
HJ190J8-150S with fan.....	9
Speed/Torque curves.....	10
Highly dynamic servo motors HDY.....	14
Options	15
Motor overview of HDY – motors	16
Dimensional drawings.....	17
HDY55C4-32S	17
HDY70C4-44S / HDY70E4-44S.....	17
HDY92C4-44S / HDY92E4-44S.....	17
HDY115A6-64S / HDY115A6-88S / HDY115C6-88S / HDY115E6-88S / HDY115G6-88S.....	18
HDY142C6-88S / HDY142G6-88S	18
Speed/Torque curves.....	19
Connecting cable to motor.....	25
Resolver cable for HJ and HDY motors	25
Motor cable for HJ and HDY – motors	26
SinCos© cable for HJ and HDY motors.....	28
Order code motors	29
Order code cables	30

Synchronous servo motors manufactured by Parker Hannifin, Electromechanical Division

Today's levels of electrical drive technology mean that different specific synchronous servo motors are required depending on the application in question.

HDY servo motors

The outstanding feature of the HDY synchronous servo motors is their low rotor inertia torque. Typical applications for these motors would be packaging machines, automatic press or assembly equipment, in which rapid acceleration and delay is required.

5 model sizes are available with mounting standards of 55, 70, 92, 115 and 142 mm in a power range of between 0.4 and 21 Nm.

HJ servo motors

The motors of the HJ range have high-quality Neodym iron-boron magnets and their rotor inertia torque is 2 to 3 times higher. The shafts (with large diameters) and the design of the rotor and bearing ensure that these motors have a higher level of shaft strength. Parker's HJ synchronous servo motors have the outstanding feature of good synchronous running properties even when running at low speeds. Typical applications for these motors would be in tooling and printing machines as well as handling robots. The HJ motors have smooth surfaces and recesses in the assembly area, which is why dirt deposits are reduced to a minimum and it is very easy to fit this unit to the gearbox.

Four model sizes of 96, 116, 155 and 190 mm are available in a power range of between 3.0 and 91 Nm.

Both the HDY and HJ ranges can be fitted with a stationary/parking brake on request. As an alternative to the resolver feedback system, SinCos[®]¹ singleturn or an absolute value sensor SinCos[®] multiturn system can be supplied.

When fitted with SV drive² and the COMPAX compact servo control unit, these motors form a drive concept for use in mains power supplies of between 230V and 460V AC.

¹ The term SinCos[®] stated in the motor catalogue is a registered trademark of the Stegmann company.

² Only supports resolver for determining motor position.

Standard servo motors of the HJ range

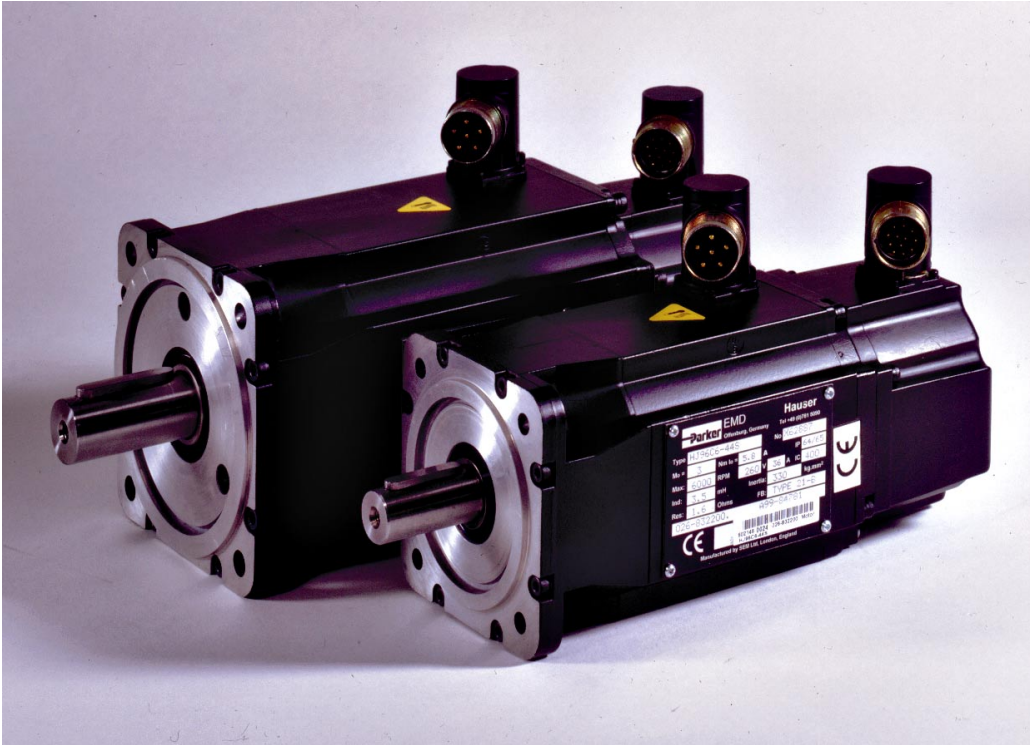

General characteristic data:

- Sinusoidal EMC.
- Painted mat black.
- Nitrile shaft seal.
- IP65³ type of protection (shaft IP64).
- Insulation class F.
- Maximum ambient temperature: 40°C
- Any installation position.
- Standard flange: standard in acc. with DIN 42955; IEC72.
- Basic body: aluminium extruded moulding
- Flange: aluminium
- Connector sockets can be rotated into almost any position (secured using a torque of 10 Nm \pm 2 Nm)
- Triple torque rating is possible for up to 3 seconds.
- Thermal sensor KTY84-130: arranged in the winding.
Switch-off temperature of COMPAX: 150°C \pm 8.5°

Version:

- With spline
- Spur thread
HJ96: M6x15
HJ116: M8x20
HJ155: M12x30
HJ190: M12x30
- Integrated resolver.

Area of application

- Packaging machines,
- shelf transport technology,
- wood machining,
- handling robots, etc.

³ with fan IP54

Options

Stationary/parking brake

The motors can be fitted with a stationary/parking brake on request. The brake is fitted in the motor housing behind the A flange (in HJ96 on the B side). This changes the mechanical dimensions of the motor. The brake is fed voltage by the motor cable.

Technical data for the 24V holding brakes:

Motor	Type	Holding torque [Nm]	J [kgmm ²]	Power [A]	Switch times [ms]	
					open	close
HJ96	Spring pressure brake	5.0	13	0.5	50	20
HJ116	Spring pressure brake	13.5	40	0.5	70	30
HJ155	Spring pressure brake	40.0	200	1.1	110	40
HJ190	Permanent solenoid brake	80.0 ⁴	3180	1.5	97	53

Attention: The stationary/parking brake does not permit any active braking.

Sensor system

A resolver is fitted in the motors as standard.

The motors can be optionally supplied with the following sensors:

- SinCos© singleturn encoder or
- SinCos© multiturn absolute value sensor

➡ By using SinCos©, the rated torque must be reduced about 10% for a correct sizing.

⁴ Applies at 20°C: reduces by 30% when at 120°C.

Motor overview of HJ – motors

Motor type	Continual stall torque M_0 Nm	Continual stall current I_0 A	Resistance Ω	Inductance μH	Entire torque constant ⁵ K_T Nm/A	Rotor inertia J kgmm ²	Weight m kg	Length ⁶ without/ with brake A mm	Power voltage ac U V ac	Rated speed N _{rated} R.P.M	Rated torque M _{rated} Nm	Rated current I _{rated} A _{eff}	Rated power P _{rated} kW
HJ ...	3.0	5.8	1.60	3500	0.51	330	5.0	218 / 258	230	4500	2.6	5.1	1.2
									400	5000	2.5	4.9	1.3
116C6-64S	5.0	6.7	1.80	6800	0.75	750	7.0	221 / 257	230	3000	4.6	6.0	1.4
									400	5000	4.0	5.0	2.1
									460	5000	4.0	5.0	2.1
116E6-88S	7.2	7.0	1.70	7700	1.02	990	8.5	246 / 282	230	2200	6.5	6.2	1.5
									400	4000	5.4	5.3	2.3
									460	4600	5.0	4.7	2.5
155A8-88S	11.5	11.2	0.77	3800	1.02	2200	13.5	237 / 276	400	4000	8.3	8.3	3.5
									460	4600	7.2	7.1	3.6
155E8-130S	25.0	16.0	0.45	5200	1.53	6500	23.0	325 / 369	400	2800	18.5	12.3	5.4
									460	3200	16.9	11.7	5.7
155G8-135S	32.0	21.0	0.37	4300	1.57	8600	28.0	369 / 408	400	2600	22.8	15.8	6.4
									460	3000	20.5	13.6	6.7
155G8-135S with fan	46.0	30.0	0.37	4300	1.57	8600	31.0	432 / 471	400	2600	38.5	26.4	10.1
									460	3000	37.2	26.1	11.3
190J8-150S with fan	91.0	52.0	0.18	1900	1.74	21000	50.0	615	400	2400	70.0	40.0	17.6
									460	2800	58.0	34.0	17.0

Tolerance: $\pm 10\%$.

The general motor values have been determined in accordance with:
the British standard BS4999 or the international Standard IEC34 • Overtemperature: 110K

Assumed is that the air can circulate freely to all sides (mounting distance approx. 30% of the edge length)

When the rated data was determined, the following tolerances were also taken into consideration:

- 10% mains power voltage.
- 17V voltage drop in the final stage.
- 10% voltage control reserve for controlled operation under the rated conditions.

The following were not taken into consideration:

- Tolerance ($\pm 10\%$) of torque constants, motor inductivity and motor resistance.
- Temperature dependency on torque constants and motor resistance.

⁵ To determine torque: torque = 0.71 * entire torque constant * transverse current (see User Guide COMPAX)

⁶ See next page.

Dimensional drawings

HJ96C6-44S

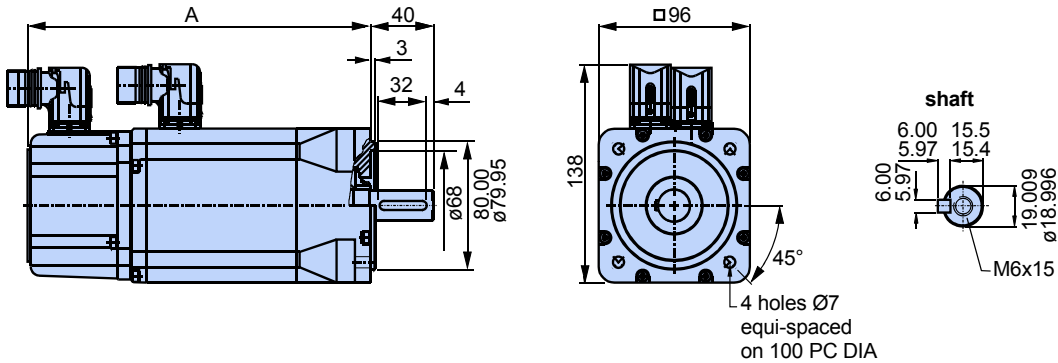

HJ116C6-64S / HJ116E6-88S

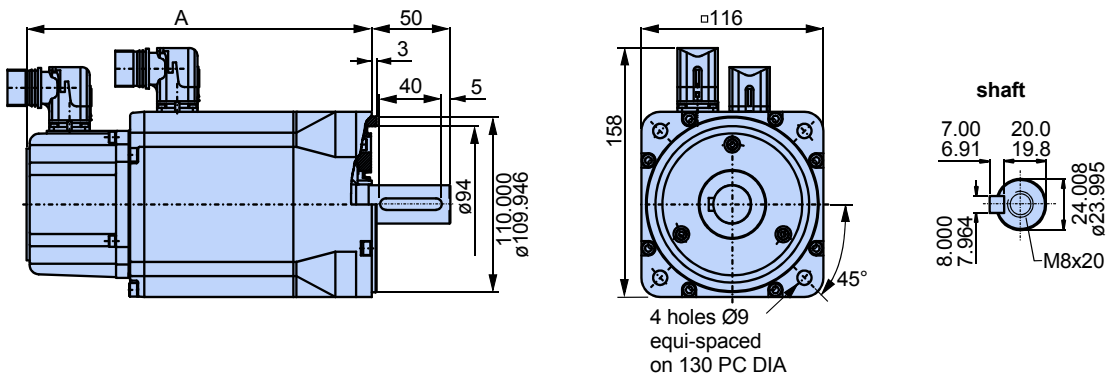

HJ155A8-88S / HJ155E8-130S / HJ155G8-135S

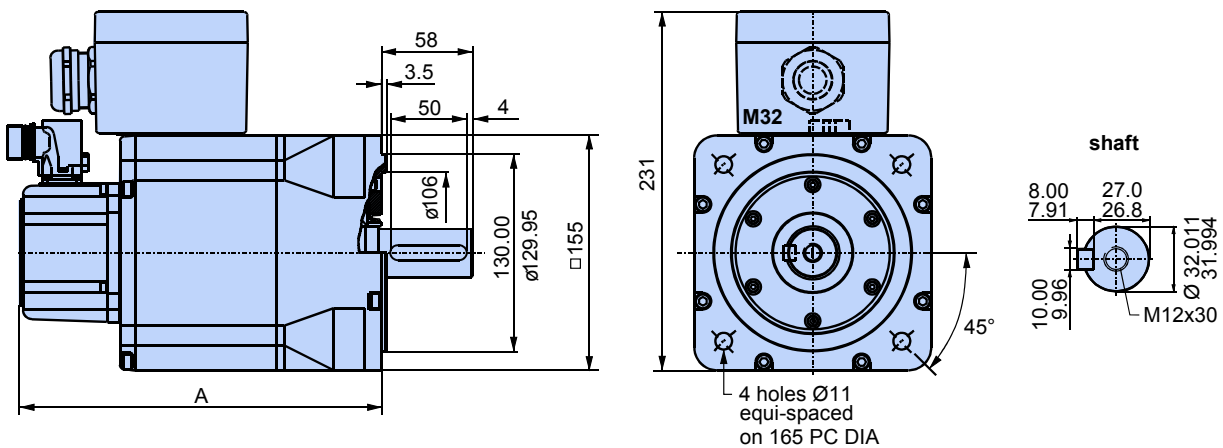

You can find the CAD-files of the dimensional drawings in the "dxf" format on our homepage.

HJ155G8-135S with fan

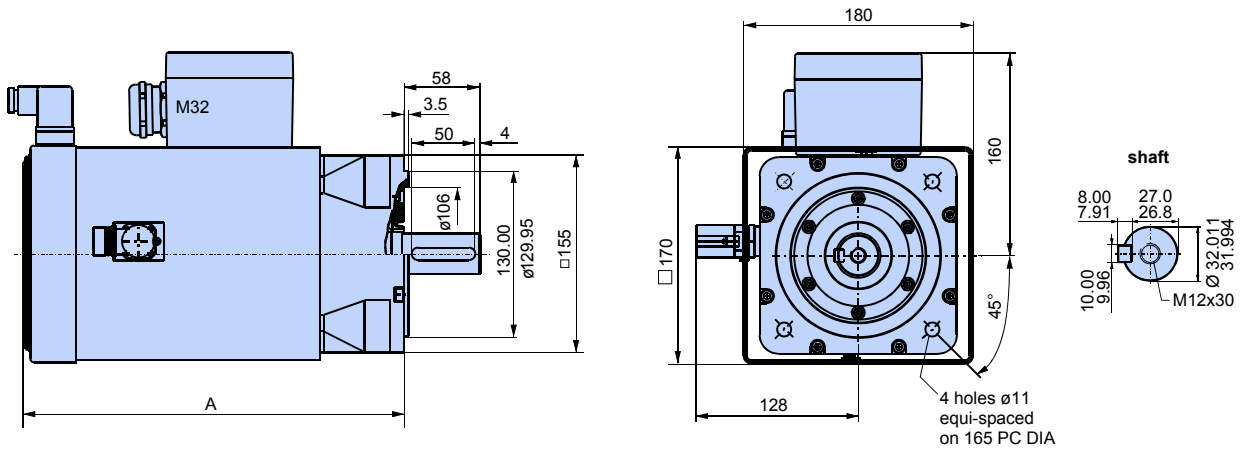

HJ190J8-150S with fan

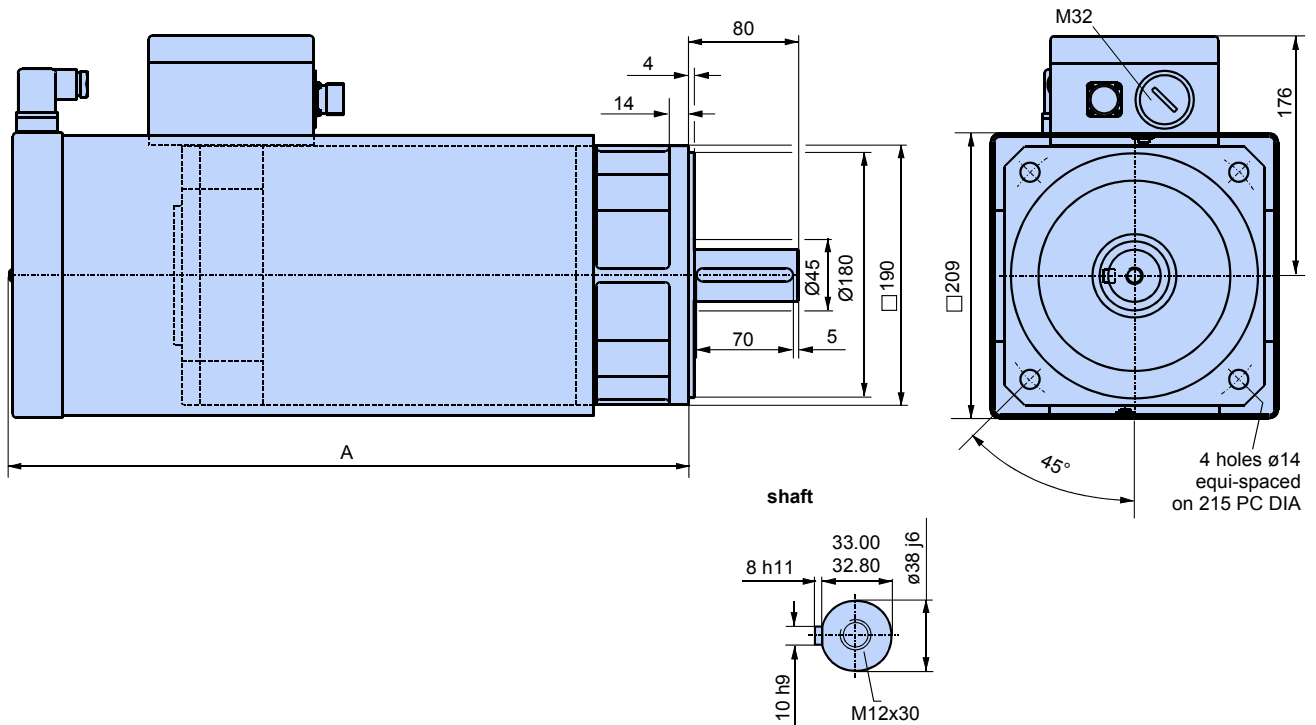

You can find the CAD-files of the dimensional drawings in the "dxf" format on our homepage.

HJ MOTORS (230 VAC)

HJ96C6-44S / SV or COMPAX2500S

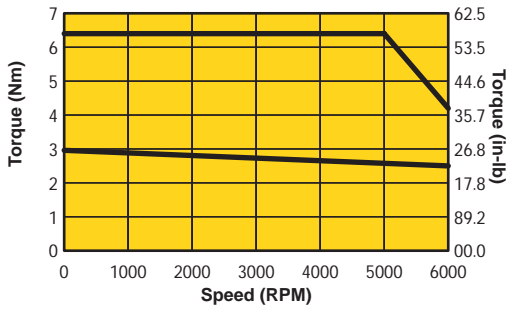

SV performance is limited to 5000rpm

HJ116C6-64S / SV or COMPAX2500S

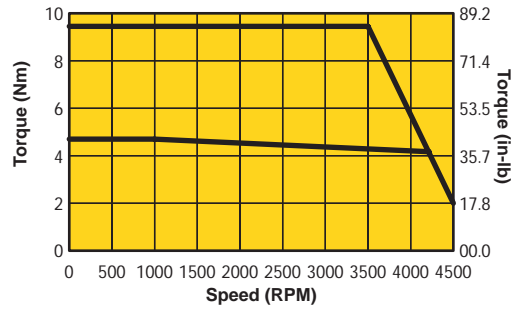

HJ MOTORS (460 VAC)

HJ96C6-44S / SV or COMPAX200M

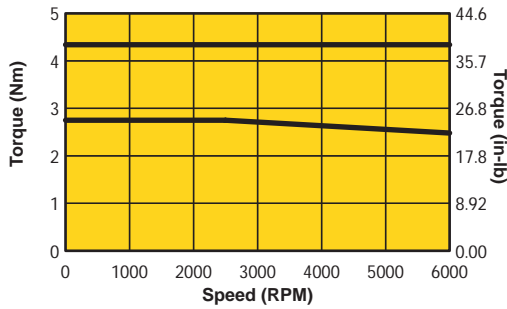

SV performance is limited to 5000rpm

HJ116E6-88S / SV or COMPAX2500S

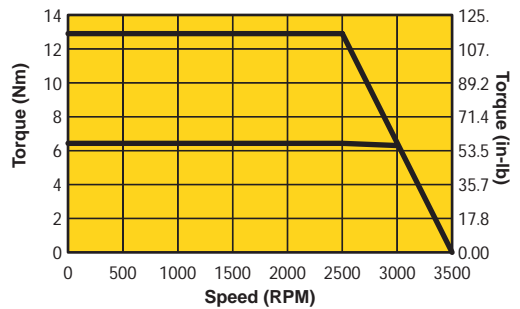

HJ96C6-44S / SV or COMPAX4500S

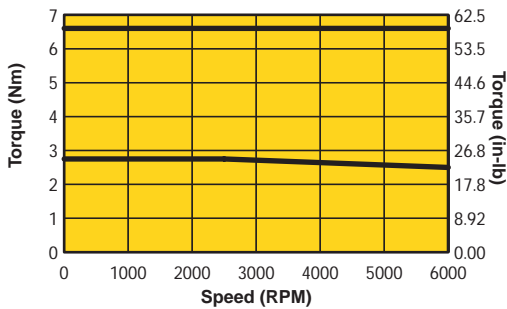

SV performance is limited to 5000rpm

HJ116C6-64S / SV or COMPAX200M

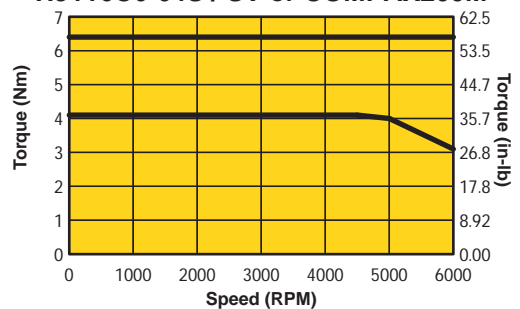

SV performance is limited to 5000rpm

HJ116C6-64S / SV or COMPAX4500S

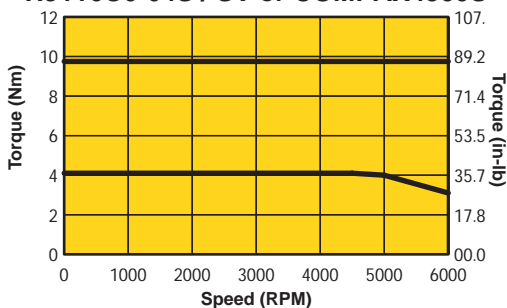

SV performance is limited to 5000rpm

HJ116C6-64S / SV or COMPAX500M

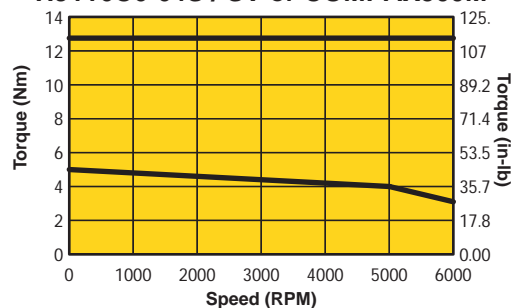

SV performance is limited to 5000rpm

HJ MOTORS (460 VAC)

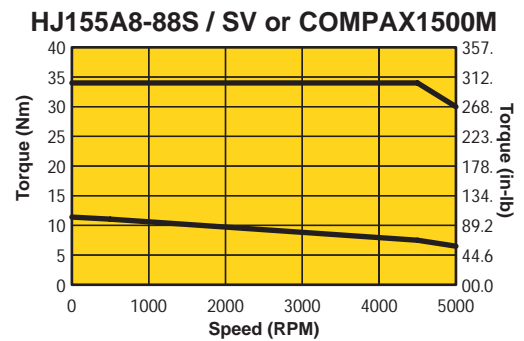
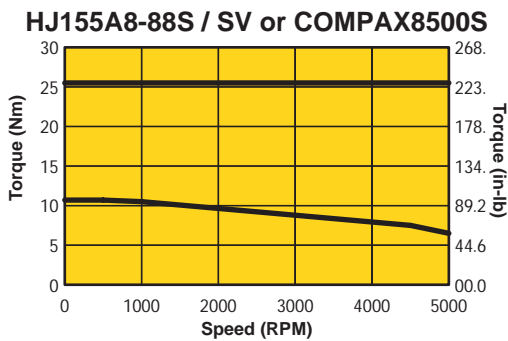
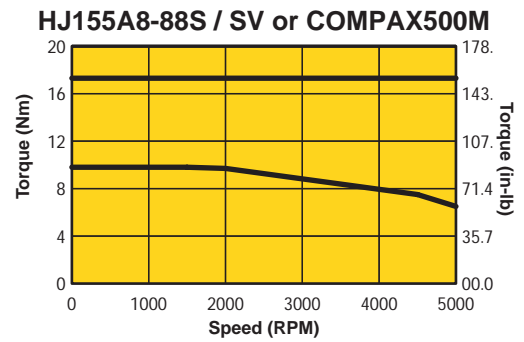
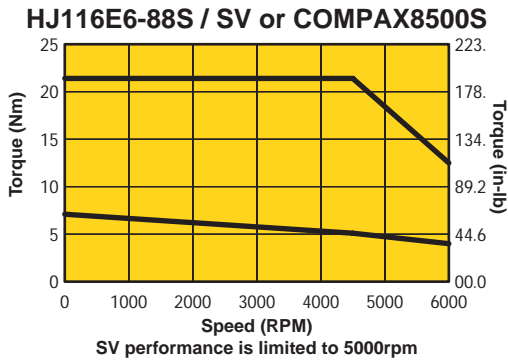
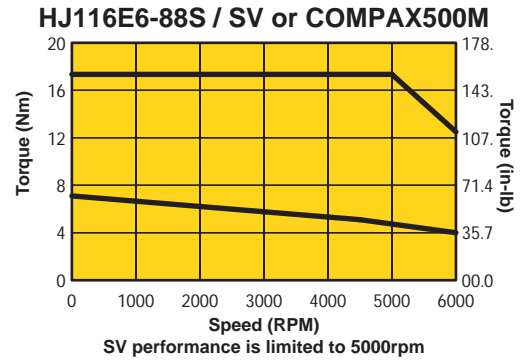
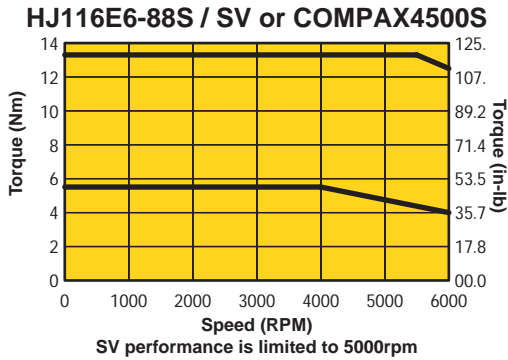
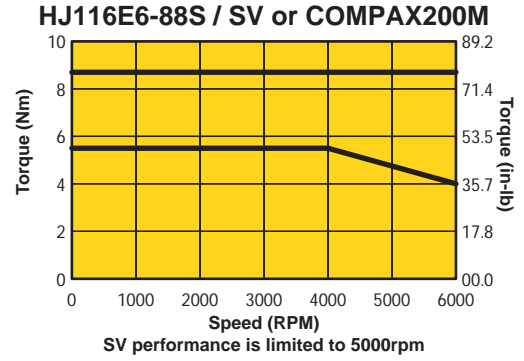
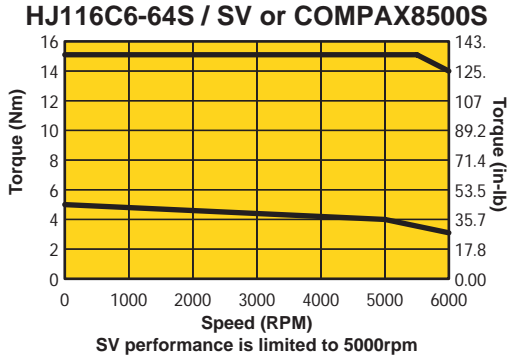

HJ MOTORS (460 VAC)

HJ155E8-130S / SV or COMPAX1500M

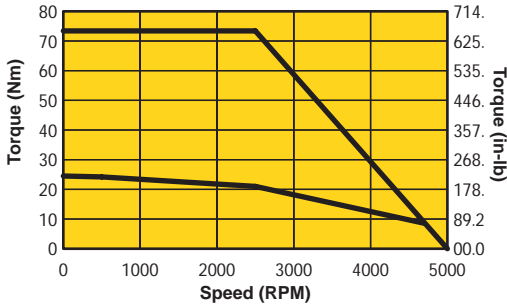

HJ155E8-130S / COMPAX3500M

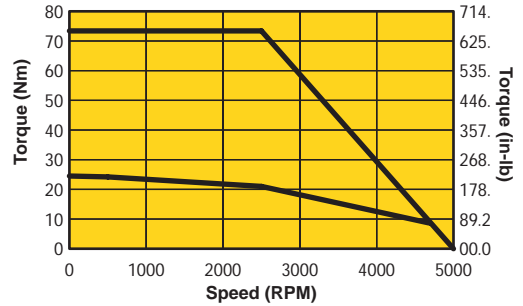

HJ155G8-135S / SV or COMPAX1500M

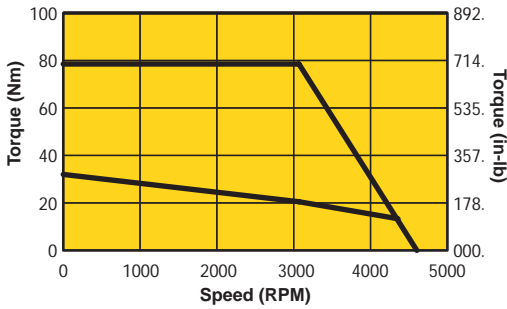

HJ155G8-135S / COMPAX3500M

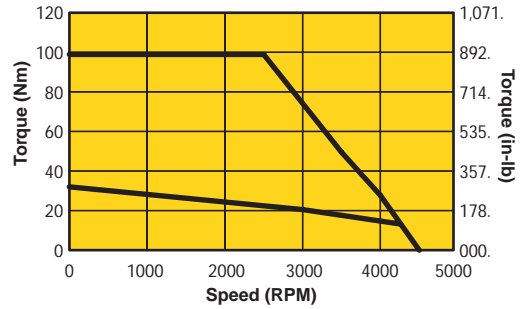

HJ155G8-135S/FN / SV or COMPAX1500M

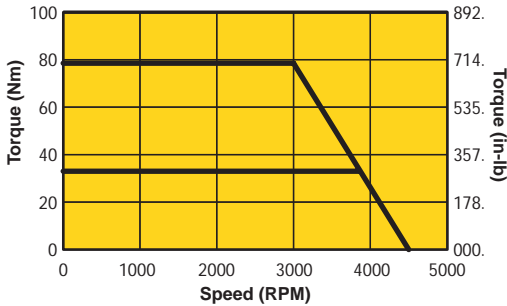

HJ155G8-135S/FN / COMPAX3500M

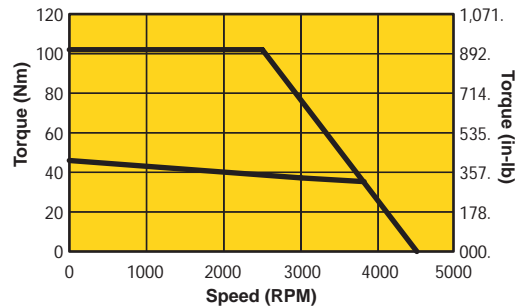

HJ190J8-150S/FN / SV or COMPAX1500M

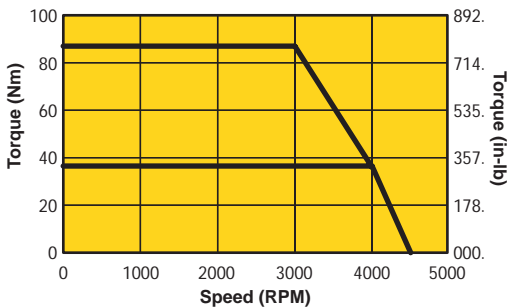

HJ190J8-150S/FN / COMPAX3500M

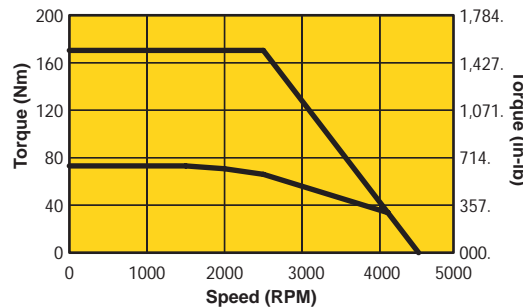

Highly dynamic servo motors HDY

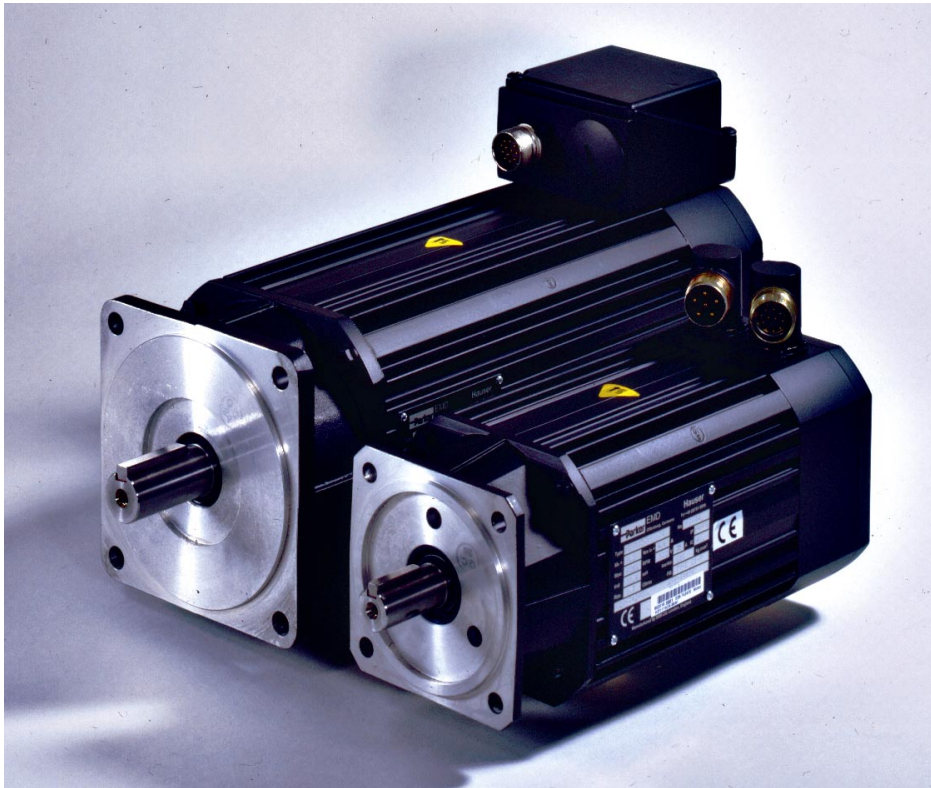

General characteristic data:

- Sinusoidal EMC.
- Painted mat black.
- Nitrile shaft seal.
- IP65 type of protection (shaft IP64).
- Insulation class F.
- Self-cooling. Max. ambient temperature: 40°C
- Any installation position.
- Standard flange: standard in acc. with DIN 42955; IEC72.
- Basic body: aluminium extruded moulding
- Flange: aluminium
- Connector sockets can be turned into almost any position (secured using a torque of 10 Nm \pm 2 Nm)
- Triple torque rating possible for up to 3 seconds.
- Thermal switch (normally closed): switches at a coil temperature of 150°C \pm 10°.

Version:

- With spline
- Spur thread
 - HDY55: M3x10
 - HDY70: M4x12
 - HDY92: M5x10
 - HDY115: M6x15
 - HDY142: M8x15
- Integrated resolver.

Area of application

Highly dynamic applications in:

- packaging machines,
- shelf transport plants,
- wood machining, etc.

Options

Stationary/parking brake

The motors can be fitted with a stationary/parking brake on request. The brake is fitted in the motor housing behind the A flange, the mechanical dimensions of the motor only change in HDY55 and HDY70. The brake is fed voltage by the motor cable.

Technical data for 24V DC holding brakes:

The values for the reinforced versions are in brackets.

Motor	Holding torque [Nm]	J [kgmm ²]	Power [A]	Switch times [ms]	
				open	close
HDY 55	1.0	1	0.29	25	20
HDY 70	1.0 (2.0)	2 (4)	0.26 (0.35)	35	10
HDY 92	5.0 (10.0)	13 (17)	0.50	50	20
HDY 115	10.0 (13.5)	17 (17)	0.50	50	20
HDY 142	18.0 (40.0)	200 (200)	1.00	110	40

Attention: the stationary/parking brake does not permit active braking.

Sensor system

A resolver is fitted as standard in the motors.

The motors can optionally be supplied with the following sensors:

- SinCos© singleturn encoder or
- SinCos© multiturn absolute value sensor

➡ By using SinCos©, the rated torque must be reduced about 10% for a correct sizing.

Altered dimensions with SinCos©

for HDY 55 (width and length; refer to dimensional diagram) and HDY 70 (only length):

Motor	Length A with SinCos© [mm]	
	Without brake	With brake
HDY55C4-44S	172	206
HDY70C4-44S	191	218
HDY70E4-44S	218	245

Motor overview of HDY – motors

Motor type	Continual stall torque M_0 Nm	Continual stall current I_0 A	Resistance Ω	Inductance μH	Entire torque constant ⁷ K_T Nm/A	Rotor inertia J kgmm ²	Weight m kg	Length ⁸ without / with brake A mm	Power voltage ac U V ac	Rated speed N_{rated} R.P.M	Rated torque M_{rated} Nm	Rated current I_{rated} A_{eff}	Rated power P_{rated} kW
55C4-32S	0.4	1.1	19.0	17000	0.375	24	1.4	140 / 176	230	5000	0.35	1.04	0.18
									400	5000	0.35	1.04	0.18
70C4-44S	1.2	2.3	4.7	12100	0.51	60	2.4	158 / 185	230	4400	1.15	2.30	0.53
									400	5000	1.10	2.30	0.58
70E4-44S	1.8	3.5	2.6	7600	0.51	80	3.2	185 / 212	230	4400	1.75	3.40	0.81
									400	5000	1.70	2.30	0.89
92C4-44S	1.5	2.9	4.6	20000	0.51	85	4.3	230	230	4400	1.20	2.40	0.55
									400	5000	1.16	2.35	0.61
92E4-44S	2.2	4.3	2.8	14000	0.51	118	5.2	250	230	4400	1.85	3.70	0.85
									400	5000	1.80	3.60	0.94
115A6-64S	3.7	4.9	2.7	15000	0.75	240	6.6	235	230	2800	3.40	4.30	1.00
									400	5000	3.10	4.00	1.60
									460	5000	3.10	4.00	1.60
115A6-88S	3.7	3.6	5.5	28000	1.02	240	6.6	235	230	2000	3.50	3.20	0.73
									400	3800	3.20	3.00	1.27
									460	4400	3.20	3.00	1.47
115C6-88S	6.8	6.6	1.7	12600	1.02	460	9.0	275	230	2000	6.00	5.80	1.25
									400	3800	5.20	5.10	2.07
									460	4400	4.90	4.90	2.26
115E6-88S	9.8	9.5	1.01	8100	1.02	680	11.4	315	400	3800	7.5	7.3	3.00
									460	4400	7.0	6.9	3.23
115G6-88S	13.0	12.6	0.63	6000	1.02	900	13.8	355	400	3800	10.0	9.4	4.00
									460	4400	9.3	9.3	4.29
142C6-88S	11.3	11.0	0.76	8900	1.02	1150	14.0	295	400	3800	8.6	8.5	3.42
									460	4400	8.3	8.3	3.82
142G6-88S	21.0	20.0	0.29	4000	1.02	2200	21.0	375	400	3800	16.0	15.6	6.36
									460	4400	15.5	15.0	7.14

The general motor values have been determined in accordance with:
the British standard BS4999 or the international Standard IEC34 • Overtemperature: 110K • Tolerance: $\pm 10\%$.
Assumed is that the air can circulate freely to all sides (mounting distance approx. 30% of the edge length)

When the rated data was determined, the following tolerances were also taken into consideration:

- 10% mains undervoltage.
- 17V voltage drop in the final stage.
- 10% voltage control reserve for controlled operation under rated conditions.

The following were not taken into consideration:

- Tolerance ($\pm 10\%$) of torque constant, motor inductivity and motor resistance.
- Temperature dependency of torque constants and motor resistance.

⁷ To determine torque: torque = 0.71 * entire torque constant * transverse current (see User Guide COMPAX)

⁸ Look at the dimensional drawings on the next page. HDY55 - and HDY70 - motors: the dimension A is only valid for motors with resolver. For motors with SinCos you will find the length A on page 1.

Dimensional drawings

HDY55C4-32S

with resolver

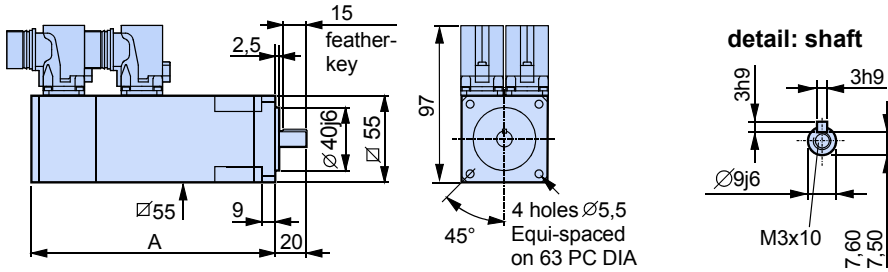

with SinCos©

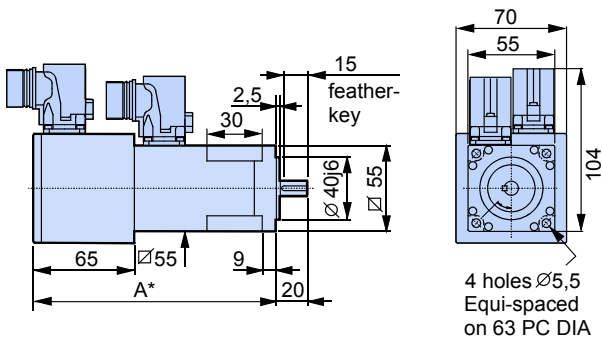

HDY70C4-44S / HDY70E4-44S

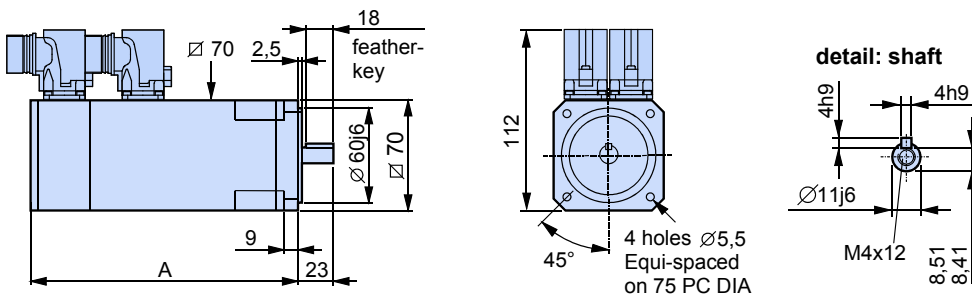

HDY92C4-44S / HDY92E4-44S

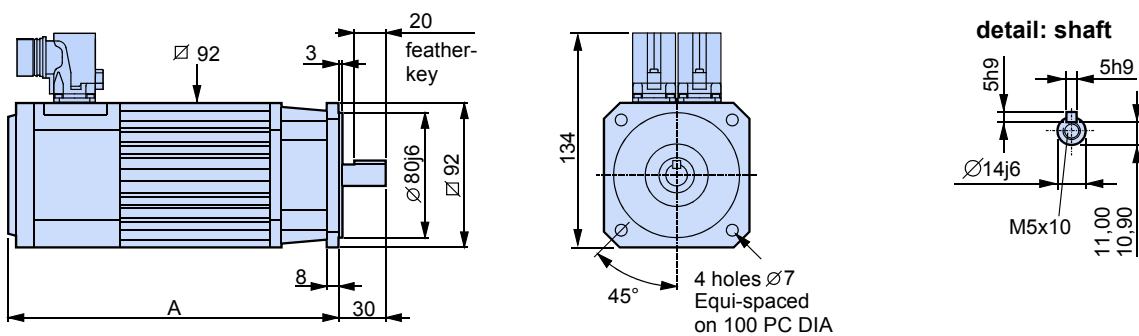

You can find the CAD-files of the dimensional drawings in the "dxf" format on our homepage.

HDY115A6-64S / HDY115A6-88S / HDY115C6-88S / HDY115E6-88S / HDY115G6-88S

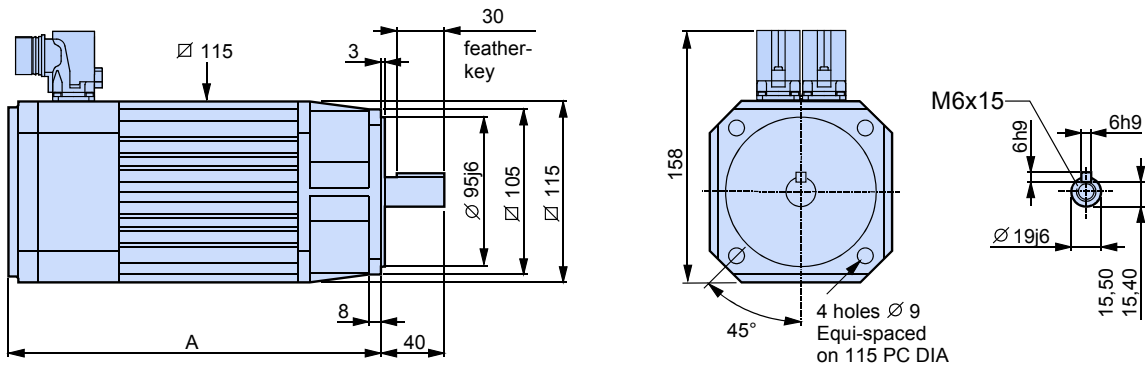

HDY142C6-88S / HDY142G6-88S

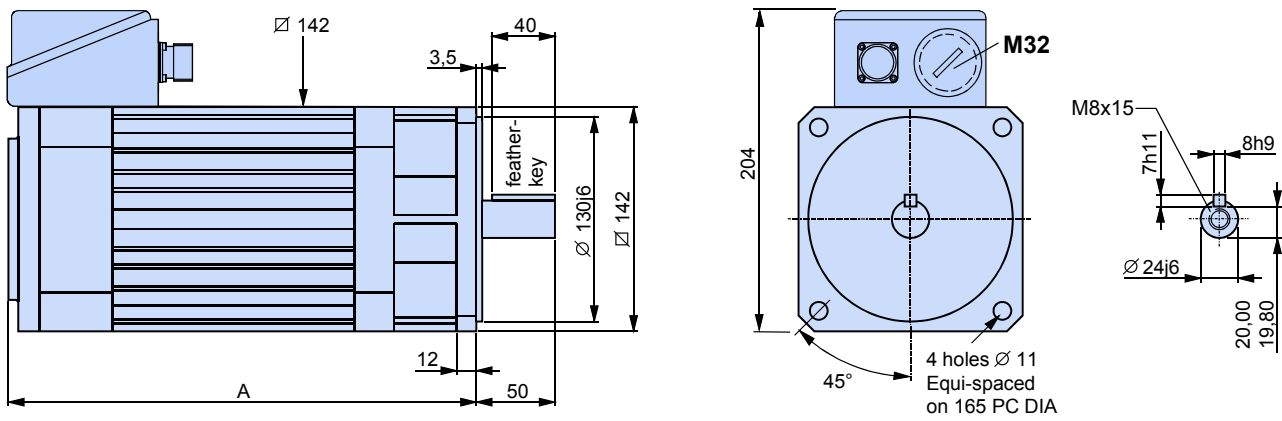

You can find the CAD-files of the dimensional drawings in the "dxf" format on our homepage.

Motor characteristics curves

HDY MOTORS (230 VAC)

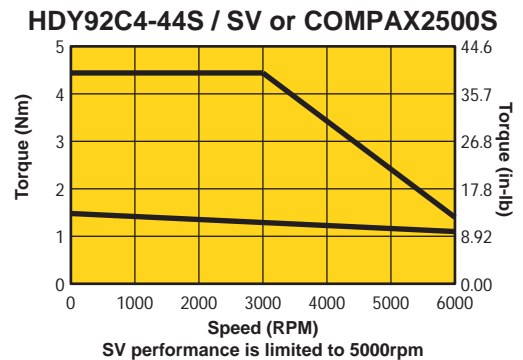
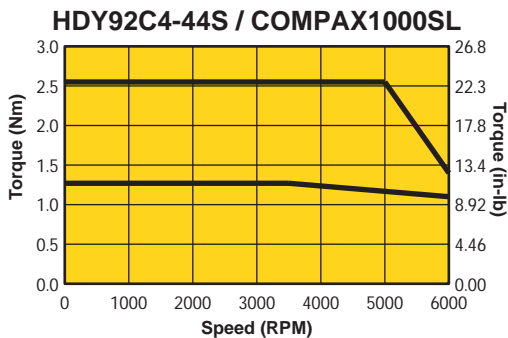
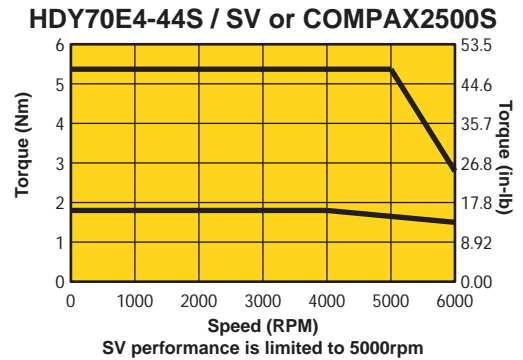
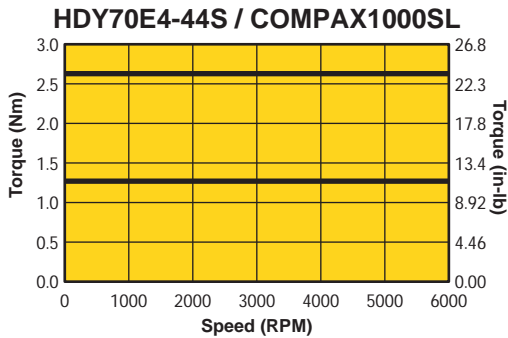
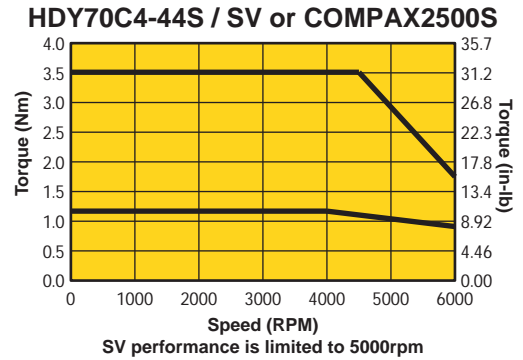
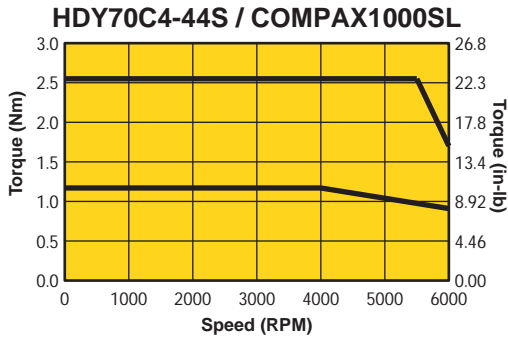
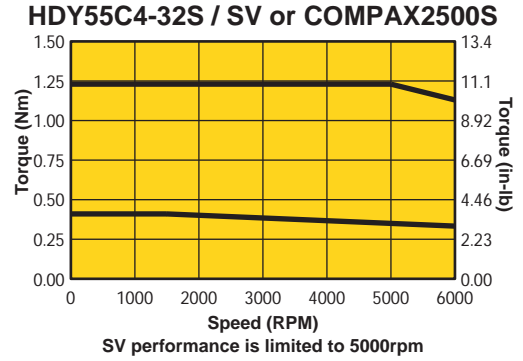
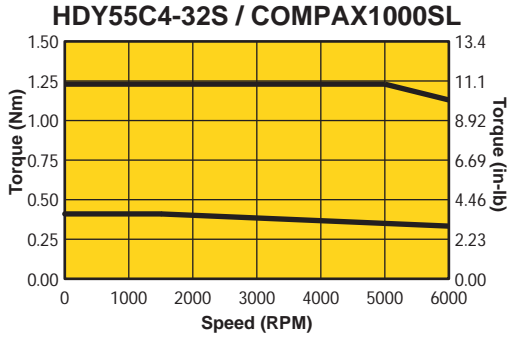

HDY MOTORS (230 VAC)

HDY92E4-44S / SV or COMPAX2500S

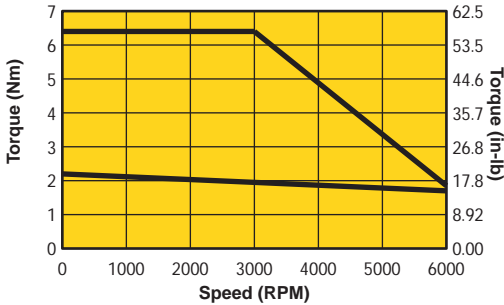

SV performance is limited to 5000rpm

HDY115A6-64S / SV or COMPAX2500S

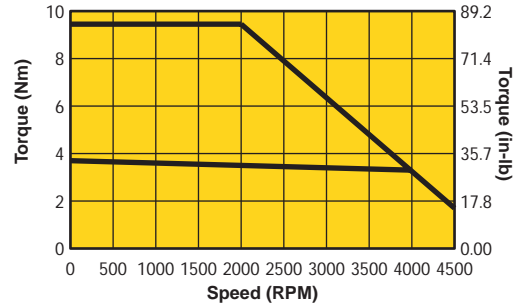

HDY115A6-88S / SV or COMPAX2500S

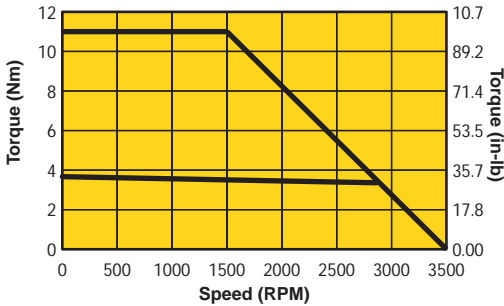

HDY115C6-88S / SV or COMPAX2500S

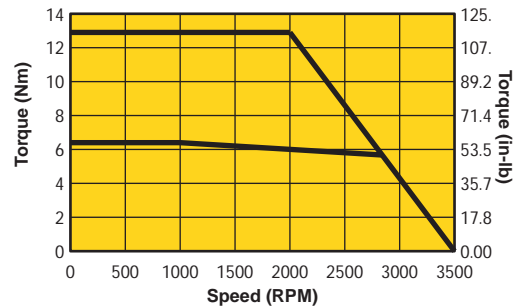

HDY MOTORS (460 VAC)

HDY55C4-32S / SV or COMPAX200M

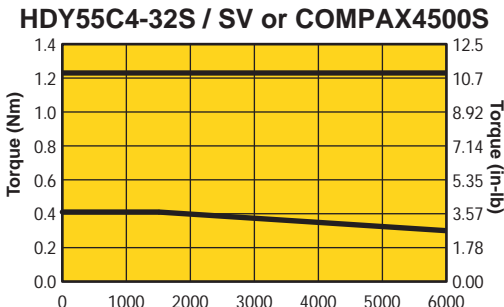

SV performance is limited to 5000rpm

HDY55C4-32S / SV or COMPAX4500S

HDY70C4-44S / SV or COMPAX200M

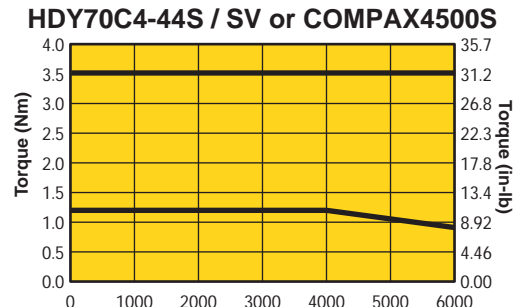

SV performance is limited to 5000rpm

HDY70E4-44S / SV or COMPAX200M

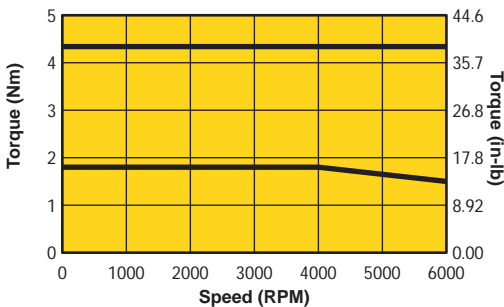

SV performance is limited to 5000rpm

HDY70E4-44S / SV or COMPAX4500S

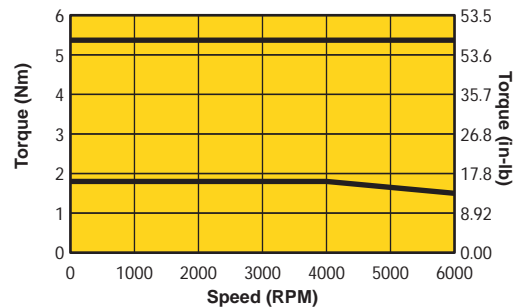

SV performance is limited to 5000rpm

HDY MOTORS (460 VAC)

HDY92C4-44S / SV or COMPAX200M

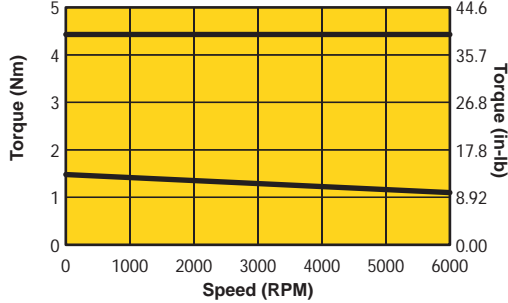

SV performance is limited to 5000rpm

HDY92C4-44S / SV or COMPAX4500S

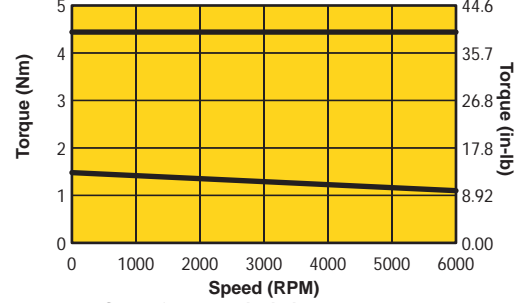

SV performance is limited to 5000rpm

HDY92E4-44S / SV or COMPAX200M

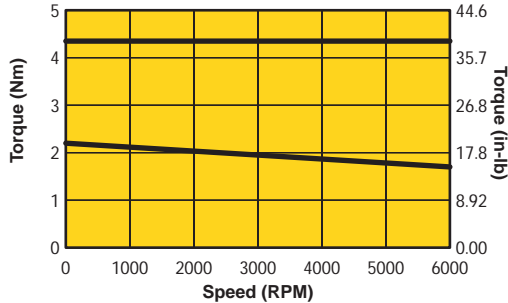

SV performance is limited to 5000rpm

HDY92E4-44S / SV or COMPAX4500S

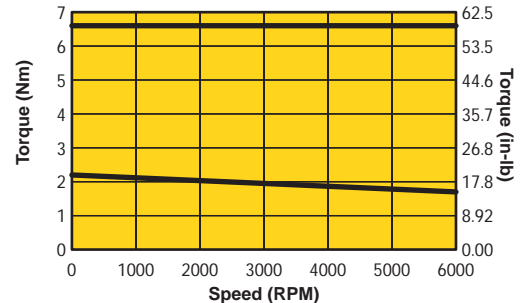

SV performance is limited to 5000rpm

HDY115A6-64S / SV or COMPAX200M

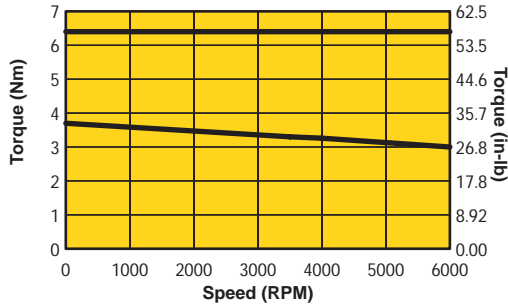

SV performance is limited to 5000rpm

HDY115A6-64S / SV or COMPAX4500S

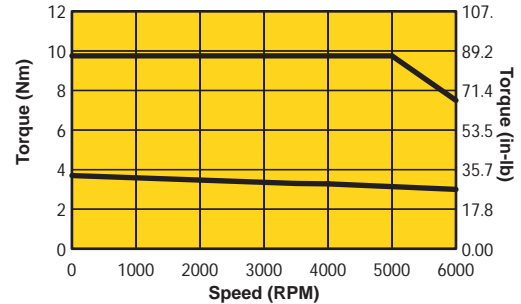

SV performance is limited to 5000rpm

HDY115A6-88S / SV or COMPAX200M

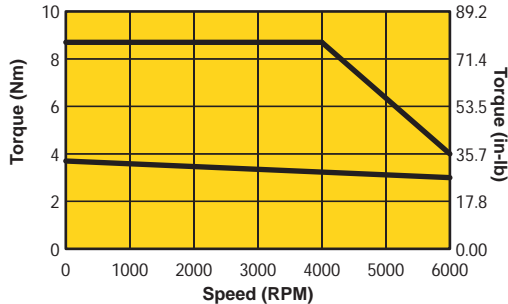

SV performance is limited to 5000rpm

HDY115A6-88S / SV or COMPAX4500S

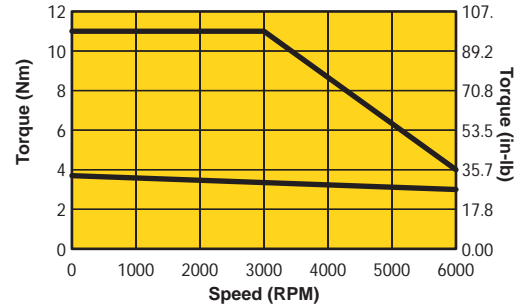

SV performance is limited to 5000rpm

HDY MOTORS (460 VAC)

HDY115C6-88S / SV or COMPAX200M

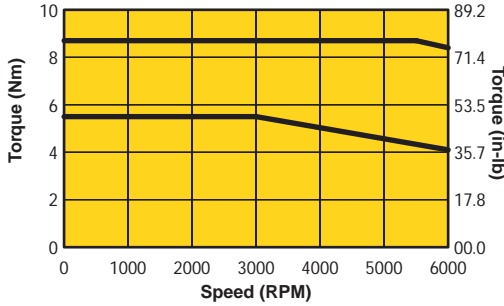

SV performance is limited to 5000rpm

HDY115C6-88S / SV or COMPAX4500S

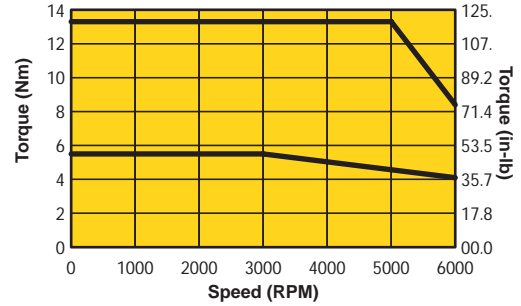

SV performance is limited to 5000rpm

HDY115C6-88S / SV or COMPAX500M

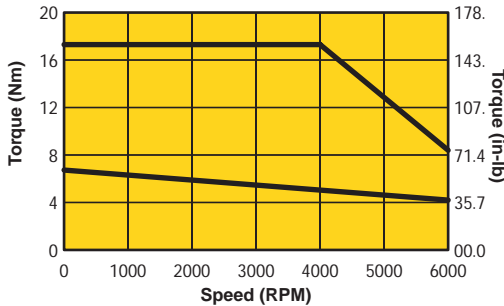

SV performance is limited to 5000rpm

HDY115C6-88S / SV or COMPAX8500S

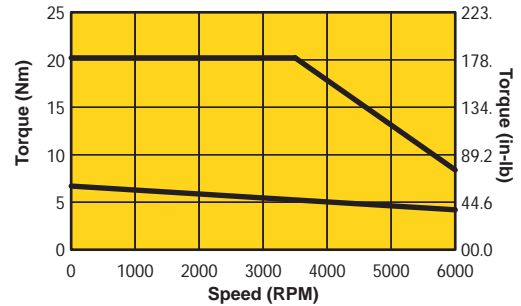

SV performance is limited to 5000rpm

HDY115E6-88S / SV or COMPAX500M

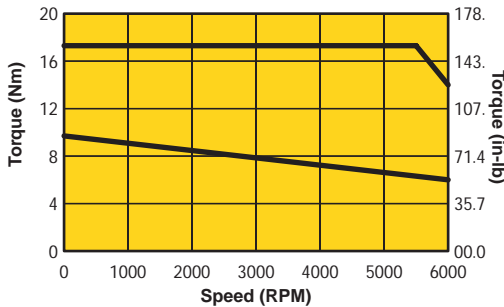

SV performance is limited to 5000rpm

HDY115E6-88S / SV or COMPAX8500S

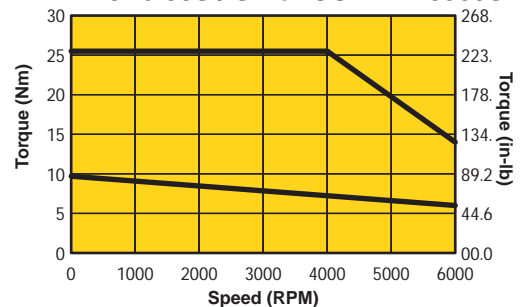

SV performance is limited to 5000rpm

HDY115G6-88S / SV or COMPAX500M

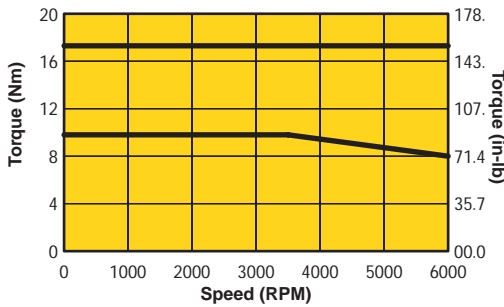

SV performance is limited to 5000rpm

HDY115G6-88S / SV or COMPAX8500S

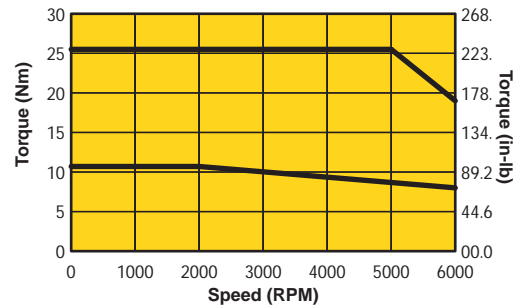

SV performance is limited to 5000rpm

HDY MOTORS (460 VAC)

HDY115G6-88S / SV or COMPAX1500M

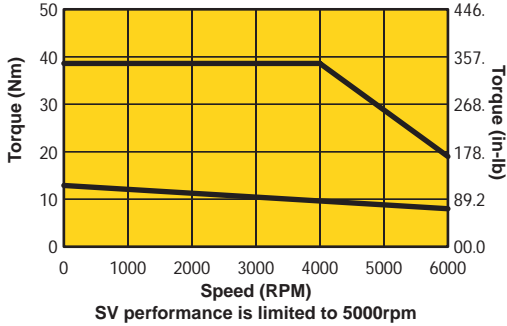

HDY142C6-88S / SV or COMPAX500M

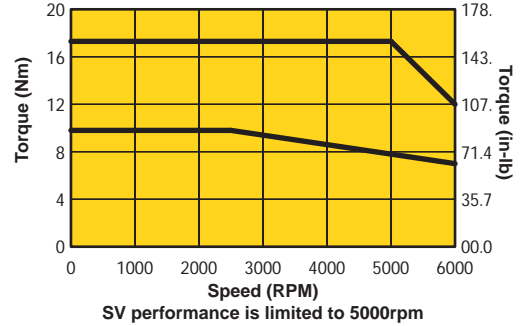

HDY142C6-88S / SV or COMPAX8500S

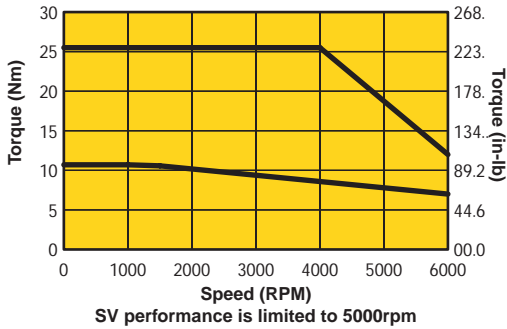

HDY142C6-88S / SV or COMPAX1500M

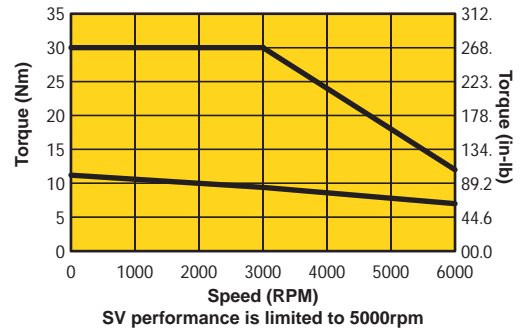

HDY142G6-88S / SV or COMPAX500M

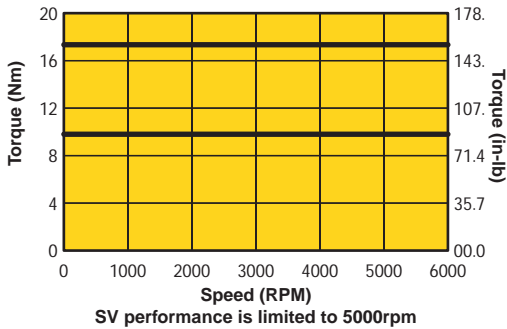

HDY142G6-88S / SV or COMPAX8500S

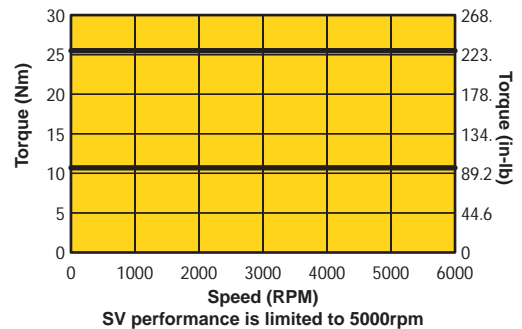

HDY142G6-88S / SV or COMPAX1500M

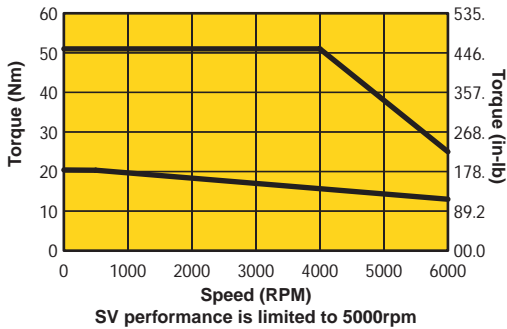

HDY142G6-88S /COMPAX3500M

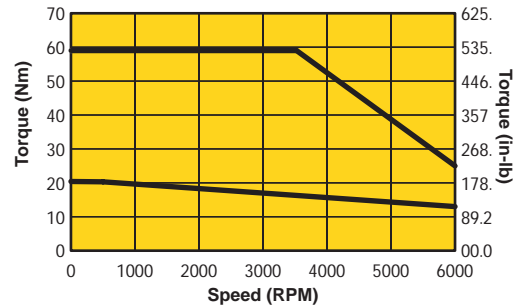

Connecting cable to motor

		Resolver cable	Sensor cable (SinCos®)	Motor cable				
				With connectors: HJ96, HJ116, HDY55, HDY70, HDY92, HDY115		With terminal boxes: HJ155, HJ190 HDY142		
				1.5mm ² up to 13.8A	2.5mm ² up to 18.9A	2.5mm ² up to 18.9A	6mm ² up to 32.3A	10mm ² up to 47.3A
Standard cable	Cable sheathed	REK32/..	GBK16/..	MOK42/..	MOK43/..	MOK21/..	MOK11/..	MOK46/..
	Connector set	085-301312 800-030031	085-301317 800-030031	085-301306	085-301306	125-518162 125-216800	125-518211 125-217000	125-518200
	Cable	102-150200	102-150210	102-508896	102-508902	102-508902	102-150030	102-150040
	Cable data in mm ⁹	8.0/80/120	7.5/38/113	10.7/107/107	13.7/137/137	13.7/137/137	16.5/124/124	22.5/168/168
High-flex cable	Cable sheathed	REK33/..	GBK17/..	MOK44/..	MOK45/..	MOK14/..	MOK11/..	MOK46/..
	Connector set	085-301312 800-030031	085-301317 800-030031	085-301306	085-301306	125-518162 125-216800	125-518211 125-217000	125-518200
	Cable	102-000030	-	102-000020	102-000010	102-000010	102-150030	102-150040
	Cable data in mm ⁹	8.2/61.5/61.5	8.0/40/64	9.2/69/69	11/82.5/82.5	11/82.5/82.5	16.5/124/124	22.5/168/168

Resolver cable for HJ and HDY motors

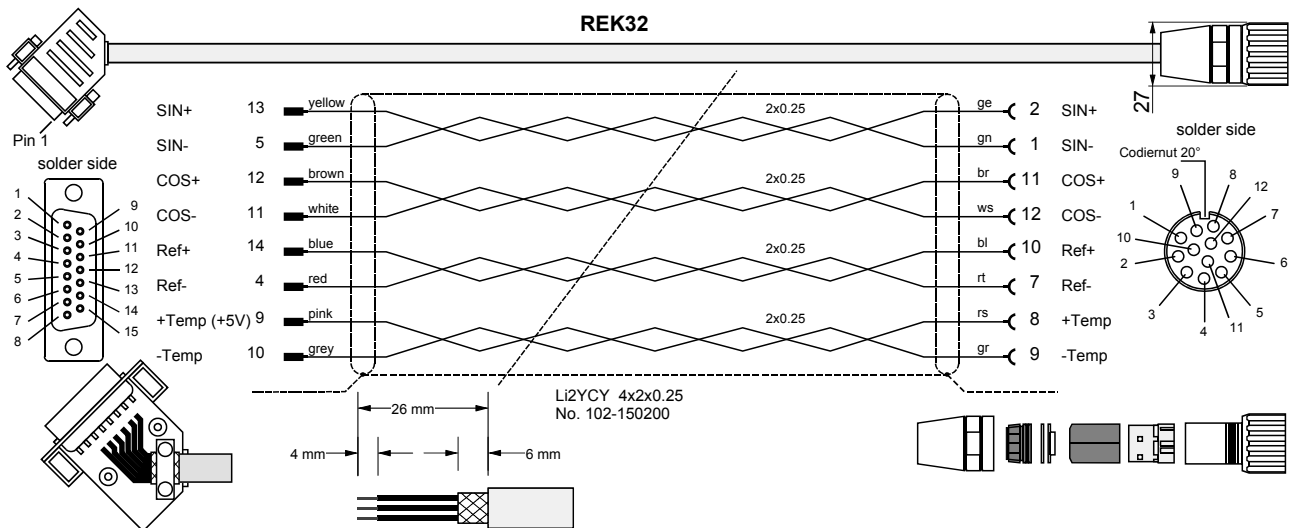

➡ In HJ – motors, ensure that the thermal sensor has the correct terminal arrangement.

Version in high-flex: REK33 (same layout)

Packaging

Packaging of motor in accordance with connector manufacturer's specification

Packaging of device

- Strip 26mm sheathing off.
- Cut sheath down to 6 mm.
- Strip 4mm of insulation of ends and coat in tin.
- Place sheath over large area of housing (e.g. fold sheath over outer cover and fasten down by relieving tension).

*⁹ Cable diameter / minimum bending radius (static) / minimum bending radius (dynamic)

Motor cable for HJ and HDY – motors

MOK42 (max. 13.8A)

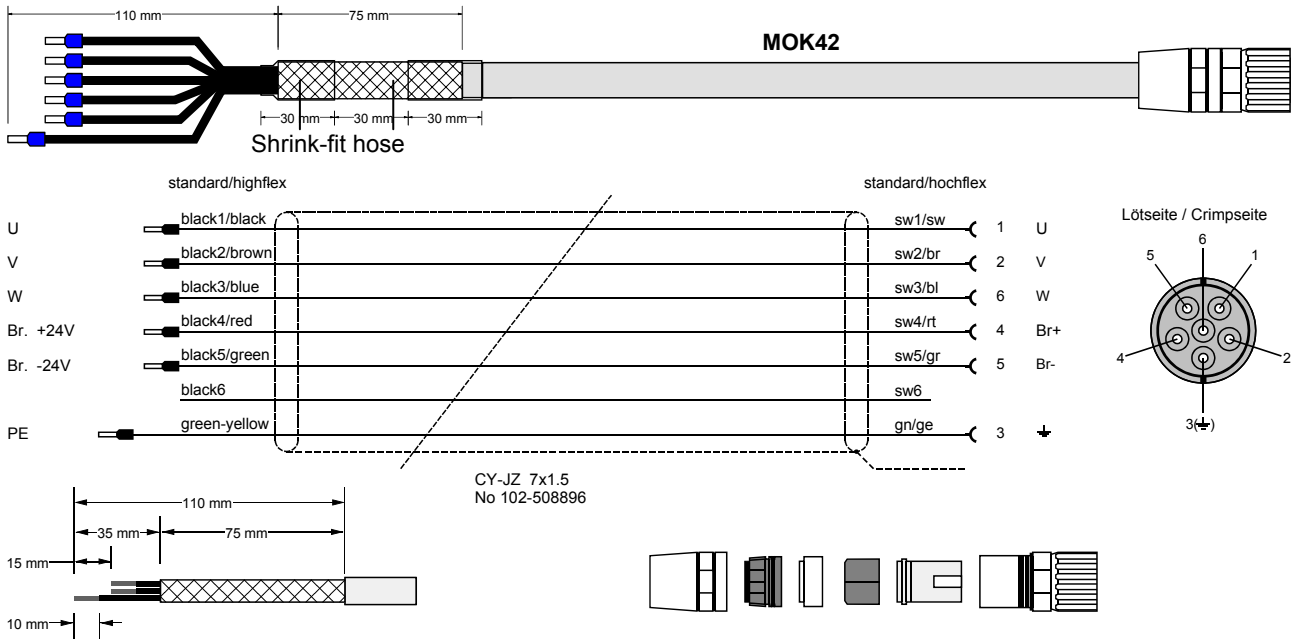

Version in high-flex: MOK44 (same layout)

MOK43/.. (max. 18.9A): HJ (version in high-flex: MOK45)

Layout corresponds to MOK42, however motor lines in 2.5 mm²

Packaging

Packaging of motor in accordance with connector manufacturer's specification

Contacts for 1.5 mm² and 2.5 mm² are supplied with the connector set.

Packaging of device

Material:

- 6 x crimping sleeves.
- 6 cm shrink-fit hose.

Procedure:

- Strip 110 mm sheathing off cable.
- Cut down sheath to approx. 35 mm, loosen,
- fold back over outer cover (approx. 75 mm) and stick with insulating tape.
- Shorten sw1,sw2,sw3,sw4,sw5 approx. 15 mm ; (gn/ge approx. 15 mm longer); cut down sw6.
- Attach 2 x approx. 30 mm shrink-fit hose (sticky).
- Strip 10 mm of insulation of ends of wires and secure with crimping sleeve 1.5.

MOK21 (max. 18.9A)

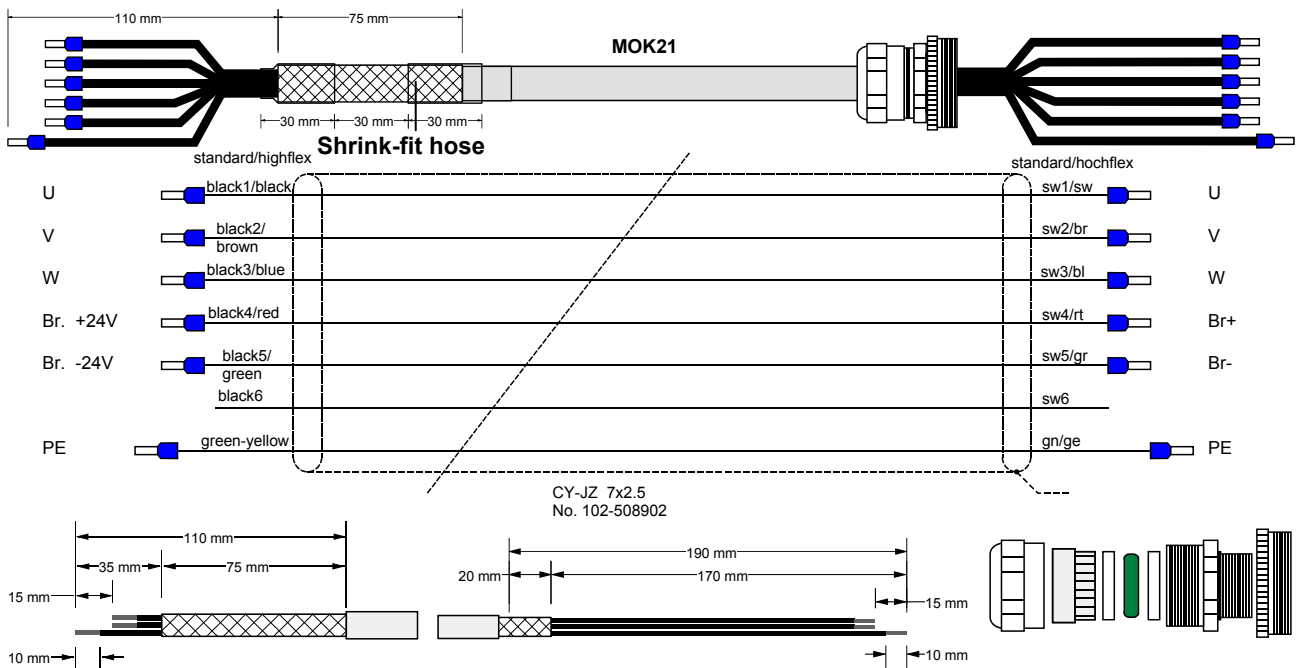

Version in high-flex: MOK14 (same layout)

MOK11 (max. 32.3A) in high-flex (same layout to MOK21, however in 6 mm²)

MOK46 (max. 47.3A) in high-flex (same layout to MOK21, however in 10mm²)

Packaging

Packaging of device

Material:

- 6 x crimping sleeves.
- 6 cm shrink-fit hose.

Procedure:

- Strip 110 mm sheathing off cable.
- Cut sheath down to approx. 35 mm, loosen,
- fold back over outer cover (approx. 75 mm) and stick with insulating tape.
- Shorten sw1,sw2,sw3,sw4,sw5 ca. 15 mm (gn/ge approx. 15 mm longer) cut down sw6.
- Attach 2 x approx. 30 mm shrink-fit hose (sticky).
- Strip 10 mm of insulation off ends of wires and secure with crimping sleeves 2.5.

Packaging of motor in accordance with manufacturer's specification

- Strip 190 mm sheathing of cable.
- Cut sheath down to approx. 170 mm, stick remaining 20 mm with insulating tape.
- Shorten sw1,sw2,sw3,sw4,sw5 by approx. 15 mm (gn/ge approx. 15 mm longer) cut down sw6.
- Strip 10 mm of insulation of ends of wires and secure with crimping sleeves 2.5.

SinCos® cable for HJ and HDY motors

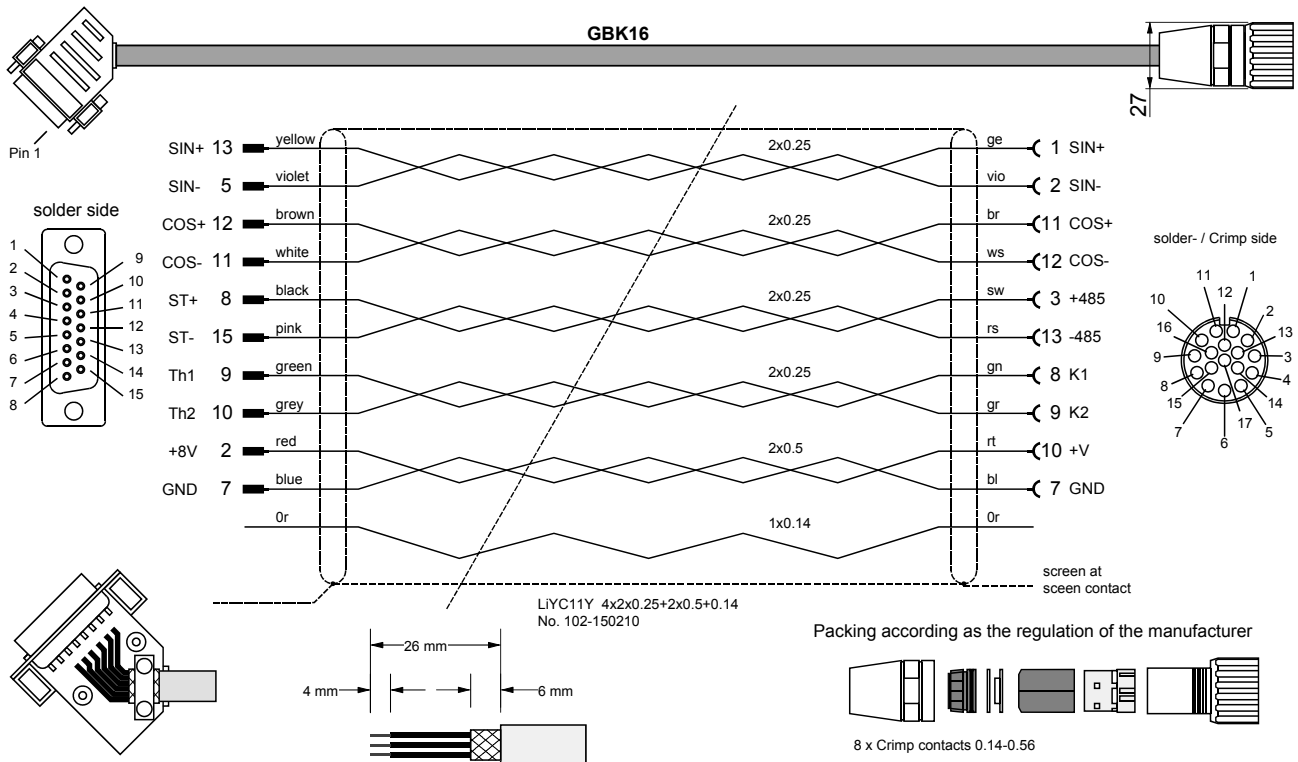

Version in high-flex: GBK17 (same layout)

Packaging

Packaging of motor in accordance with connector manufacturer's specification

Packaging of device

- Strip 26mm sheathing off.
- Cut sheath down to 6 mm.
- Strip 4mm of insulation of ends and coat in tin.
- Place sheath over large area of housing (e.g. fold sheath over outer cover and fasten down by relieving tension).

Order code cables

Motor cable, resolver cable, encoder cable

Motor cable for HJ96, HJ116, HDY55, HDY70, HDY92, HDY115														
Motor cable 1.5mm ² standard (<13.8A)	M	O	K	4	2									
Motor cable 1.5mm ² highly flexible (<13.8A)	M	O	K	4	4									
Motor cable 2.5mm ² standard (<18.9A)	M	O	K	4	3									
Motor cable 2.5mm ² highly flexible (<18.9A)	M	O	K	4	5									
Motor cable for HJ155, HJ190, HDY142														
Motor cable 2.5mm ² standard (<18.9A)	M	O	K	2	1									
Motor cable 2.5mm ² highly flexible (<18.9A)	M	O	K	1	4									
Motor cable for HJ155, HJ190, HDY142														
Motor cable 6mm ² highly flexible (= standard) (<32.3A)	M	O	K	1	1									
Motor cable for HJ155, HJ190, HDY142														
Motor cable 10mm ² highly flexible (= standard) (<47.3A)	M	O	K	4	6									
Resolver cable (identical for all motors)														
Resolver cable standard	R	E	K	3	2									
Resolver cable highly flexible	R	E	K	3	3									
Encoder cable (identical for all motors)														
Encoder cable (SInCos©) standard	G	B	K	1	6									
Encoder cable (SInCos©) highly flexible	G	B	K	1	7									
Length of ready-made cables see following table														
Example: requested length 25m											0	9		

Length [m]	1.0	2.5	5.0	7.5	10.0	12.5	15.0	20.0	25.0	30.0	35.0	40.0	45.0	50.0
Code	01	02	03	04	05	06	07	08	09	10	11	12	13	14

Lengths indicated in bold print are preferred.