

Trilogy Linear Motor Engineering Reference Guide

aerospace
climate control
electromechanical
filtration
fluid & gas handling
hydraulics
pneumatics
process control
sealing & shielding



ENGINEERING YOUR SUCCESS.

Linear Motor Engineering Reference Guide

1. Advantages of linear motors

1.1 What are linear motors?

Simply stated, a linear motor is the same as a rotary motor that has been “unwrapped.” They operate exactly the same as rotary motors, where the same electromagnetic equations that describe how a rotary motor produces torque now describe how a linear motor produces a direct force.

In many applications, linear motors offer distinct advantages over conventional rotary drive systems. When using a linear motor, there is no need to couple the motor to the load by means of intermediate mechanical components such as gears, ballscrews, or belt drives. The load is directly connected to the motor. Therefore, there is no backlash or elasticity from the moving elements. Thus, the dynamic behavior of the servo control is improved and higher levels of accuracy are achieved.

The absence of a mechanical transmission component results in a drive system with low inertia and noise. In addition, mechanical wear only occurs in the guidance system. As a result, linear motors have better reliability and lower frictional losses than traditional rotary drive systems.

1.2 Differences in construction

The differences in construction between a direct-drive linear motor and a conventional rotary drive system are shown in (Fig. 1 and Fig. 2,) using the examples of a linear motor drive and a ballscrew drive. Due to the absence of mechanical transmission elements converting rotary movement into linear movement, the axis fitted with a linear motor has a much simpler mechanical construction, resulting in a low-inertia drive for highly dynamic applications. Though not always required, the linear motor table is equipped with a linear encoder, which provides extremely accurate positional feedback.

Though the linear encoder in (Fig. 2) can be considered a high-cost component, the selection of the feedback system can be optimally suited to the requirements of the application. For instance, Parker offers extremely high-resolution optical encoders for applications with demanding precision requirements. In addition, Parker offers lower-resolution, low-cost magnetic encoders for applications where overall system cost is a concern. Actually, it is not uncommon for a linear motor with an economical form of feedback to outperform and actually cost the same or even less than a rotary system using a precision ground ballscrew.

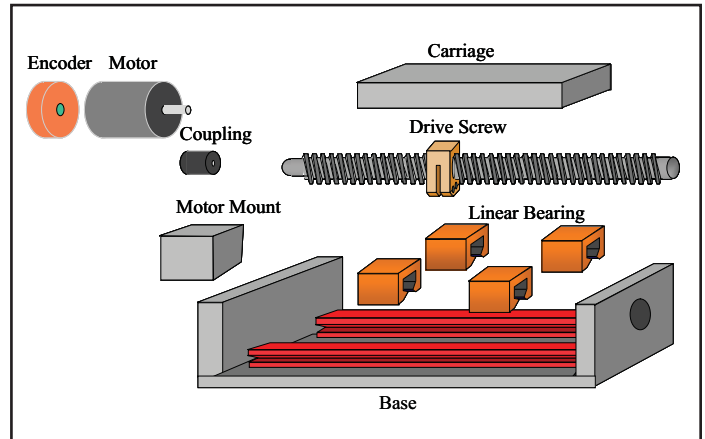

Fig. 1: Precision table fitted with ballscrew drive

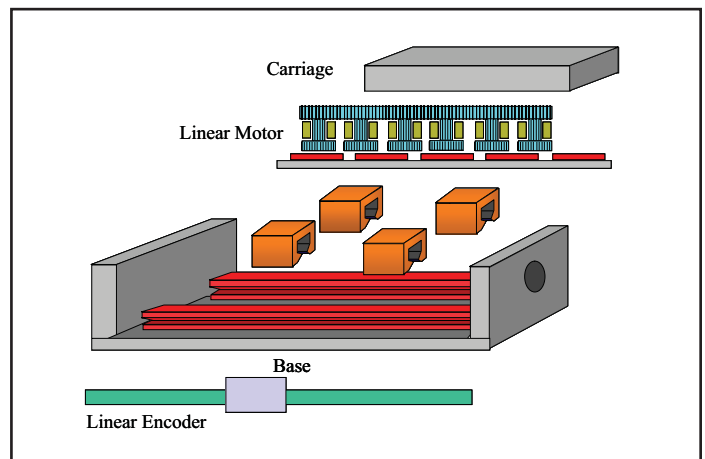

Fig. 2: Precision table fitted with linear motor



Fig. 3: Linear motor components include a separate coil and magnet rail

2.0 Types of linear motors

There are many different types of linear motors. Each type exhibits its inherent advantages and benefits to the user. Parker manufactures 3 styles of linear motors – ironless, ironcore, and an interesting variant known as the “slotless” design.

Linear motors are either offered as individual components or complete systems. Components, or “kits” (Fig. 3), consist of a motor coil and separate magnet rail. The coil assembly is known as the “forcer” or sometimes as the “primary” element. The forcer generally consists of the motor coil and an attachment plate or mounting bar which allows the coil to connect to the carriage.

The motor cables typically exit from one side of the package. The magnet track is sometimes referred to as the “secondary” element. Depending on the type of linear motor used, the magnet track can either be a single row of magnets or a double-sided configuration offering balanced attraction forces.

A complete linear motor system (Fig. 4) is typically made up of the individual motor components, base, bearings, feedback elements, and cable management.



Fig. 4: Linear motor positioning systems include a base, bearings, carriage, feedback and typically cable management

By selecting linear motor components, the user is given an economical solution and is allowed complete flexibility with respect to integration into the machine. However, this requires a high degree of specific knowledge on the part of the machine builder. The designing engineer must have an understanding of the motor characteristics, linear feedback technology, cooling methods, and the performance of the servo amplifier and control system.

By selecting integrated linear motor positioning systems, the design engineer is given a pre-engineered, robustly designed, fully tested package. This takes the worry out of designing and aligning bearings, encoders, heat sinks, cables, connectors, travel stops, and limit / home sensors. Parker linear motor tables provide all this and more in easily mounted and ready-to-run packages.

2.1 Ironcore motors

Ironcore motors consist of aforcer which rides over a single magnet rail (Fig. 5). The forcer is made of copper windings wrapped around iron laminations. The back iron provides an efficient path for the magnetic flux to circulate between the motor and the magnet rail. In addition, there is an efficient path for heat to escape the motor. This ironcore design allows for extremely high forces and efficient cooling. In fact, the ironcore design offers the highest force available per unit volume. Finally, the ironcore design is economically attractive because only one row of magnet material is required.

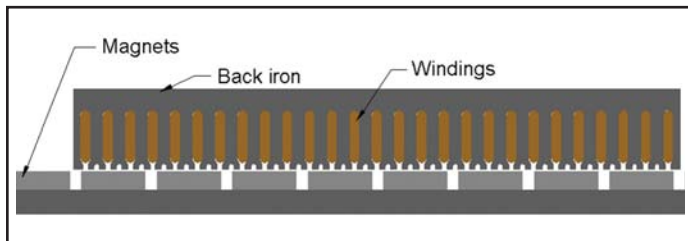

Fig. 5: Ironcore linear motor

One of the drawbacks of the ironcore design is that the motor has a high attractive force between the forcer and the magnet track. The attractive force can range from 5 – 13 times the rated force of the motor. This force must be supported by the bearing system of the motor. In addition, the high attractive force makes installation more challenging than other linear motor designs.

Another drawback of the ironcore design is the presence of cogging forces. Cogging occurs when the iron laminations exert a horizontal force on the motor in order to line up with their preferred positions over the magnets. Cogging limits the smoothness of motion systems because the force generated by the motor must change with position in order to maintain a constant velocity.

Parker Trilogy has developed a patent-pending Anti-Cog technology that virtually eliminates cogging and allows ironcore motors to be used in applications where only ironless motors were considered before. This offers the machine builder a powerful combination of extremely high force and smooth operation in an economical package.

To summarize the advantages and disadvantages of ironcore motors:

Ironcore advantages:

- **High Force per Size** - Uses laminations to concentrate the flux field.
- **Lower Cost** - Open face design only uses one row of magnets.
- **Good Heat Dissipation** - Because of laminations and large surface area, heat can be removed easily.

Ironcore disadvantages:

- **Normal attractive force** – 5 to 13 times greater than force generated.
- **Cogging** – Limits the smoothness of motion and creates velocity ripple. *This is counteracted by Parker Trilogy's patent pending Anti-Cog technology.*

Parker Trilogy offers ironcore motors both as components and as pre-engineered, fully integrated positioning systems. Please refer to the catalog for the **RIPPED Series** Ironcore Linear Motors and the **TR Series** Ironcore Linear Motor Positioners (Fig. 6 and Fig. 7).



Fig. 6: Ripped Series Ironcore Linear Motor

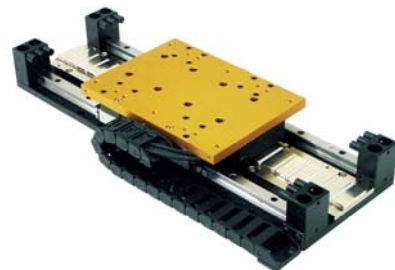

Fig. 7: Parker Trilogy's TR Series Ironcore Linear Motor Positioner

2.2 Ironless Motors

Ironless motors consist of aforcer which rides between dual magnet rails (Fig. 8). They are also known as “aircore” or “U-channel” motors. The forcer does not have any iron laminations in the coil – hence the name ironless. Instead, the copper windings are encapsulated and located in the air gap between the two rows of magnets. Because the motors are ironless, there are no attractive forces or cogging forces between the forcer and the magnet track.

In addition, the forcers have lower mass than their ironcore counterparts. What results is a motor design that allows for extremely high accelerations and overall dynamic performance. The ironless design has zero cogging and the lack of attractive force allows for extended bearing life and, in some applications, the ability to use smaller bearings.

While the high dynamic performance and zero cogging motion make the ironless motors a powerful design, they are not as thermally efficient as their ironcore counterparts. A small contacting surface area and a long thermal path from the winding base to the cooling plate makes the full-load power of these motors low. In addition, the dual row of magnets increases the overall cost of these motors in relation to the generated force and stroke length.

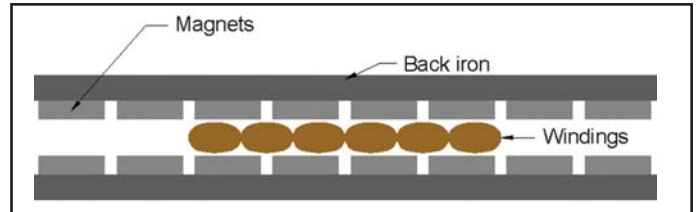

Fig. 8: Ironless Linear Motor

Parker Trilogy’s patented I-beam shape and overlapping winding design provides very high forces in a compact package. In addition, the design is more thermally efficient than tradition ironless motor designs.

By overlapping the windings (Fig. 9) instead of arranging them side-by-side, Parker Trilogy is able to provide a motor with a very high power density. The result is a package size considerably smaller than competitive motors with similar force capabilities.

Parker Trilogy creates the I-beam shape by flaring out the end turns of the motor at a 90-degree angle. The end turns of a linear motor coil do not contribute to the horizontal force component of the motor. Instead of producing force, the end turns simply produce heat. Parker’s I-beam shaped design allows for better heat transfer between the motor coils and the heat sink by increasing the contacting surface area between components (Fig. 10). The combination of overlapped windings and the I-Beam shape creates a more thermally efficient motor than most traditional ironless motors. As a result, the payload will experience less thermal expansion due to heat from the motor. In high precision applications, thermal expansion can adversely affect the overall system accuracy. Parker Trilogy motors will help maintain system accuracy by running at lower operating temperatures than our competitors. In addition, there are added benefits of the I-beam shape by lowering the overall profile height and creating a stiffer mechanical structure.

What results is a compact motor design with high force and extraordinary thermal characteristics.

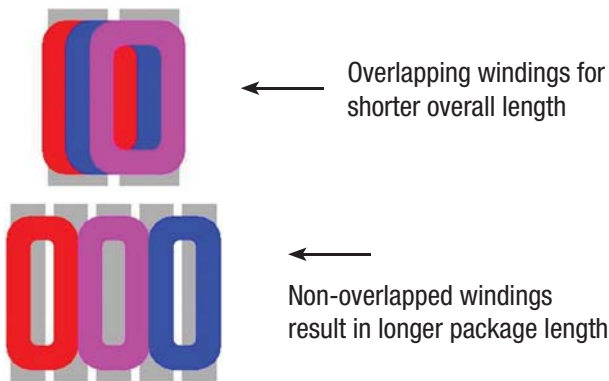

Fig. 9: Overlapping Windings

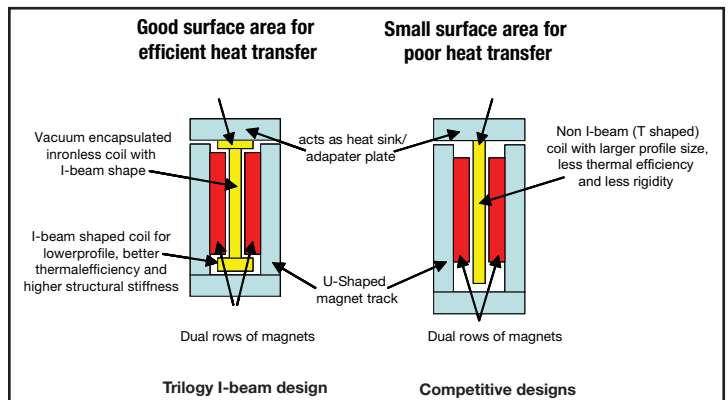

Fig. 10: Parker Trilogy’s Patented I-Beam Design

To summarize the advantages and disadvantages of ironless motor designs:

Ironless advantages:

- **No Attractive Force** - Balanced dual magnet track. Safe and easy to handle. No forces to deal with during assembly.
- **No Cogging** - Ironless forcer for zero cogging and ultimate smoothness.
- **Low Weight Forcer** - No iron means higher acceleration and deceleration rates, higher mechanical bandwidth.
- **Air Gap Forgiving** - easy to align and install.

Ironless disadvantages:

- **Heat dissipation** - Higher thermal resistance. Parker Trilogy's I-beam design helps mitigate this issue.
- **Power per package** - Lower RMS power when compared to ironcore designs.
- **Higher cost** - Uses twice as many magnets.

Parker Trilogy offers ironless motors in both component kits and complete pre-engineered positioning systems. Please refer to the catalog for the “**I-Force**” and “**ML50**” ironless linear motors and the “**T Series**” linear motors positioners (Fig. 11 and 12).



Fig. 11: ML50 Ironless Linear Motor

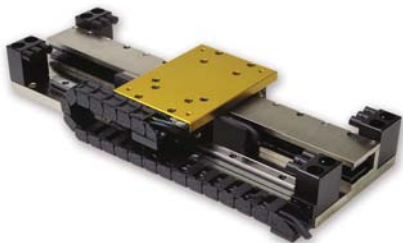

Fig. 12: T2D Series Linear Motor Positioner

2.3 Slotless Motors

Slotless motors are an interesting variant of linear motor which combines several of the design elements of ironcore and ironless motors. In a slotless motor (Fig. 13), the forcer has no iron toothed laminations. The coils are wound without iron and are located underneath a “back iron” plate. The forcer then operates along a single magnet row. The slotless motor design can be thought of as a sort of hybrid between ironcore and ironless linear motor designs.

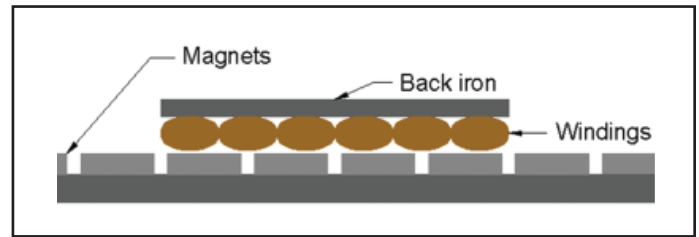

Fig. 13: Slotless Linear Motor

What results is a motor with the following characteristics:

Slotless linear motor advantages:

- Single-row magnet bar
- Lower cost (compared to ironless design)
- Better heat dissipation (compared to ironless design)
- More force per package size (compared to ironless design)
- Lighter weight and lower inertia forcer (compared to ironcore design)
- Lower attractive forces (compared to ironcore designs) – extended bearing life and smaller bearings in some applications
- Less cogging (compared to ironcore designs)

Slotless linear motor disadvantages:

- Some attractive force and cogging
- Air gap is critical
- Less efficient than both ironcore and ironless – more heat to do the same job

Parker offers slotless motors in both component kits and precision positioning systems. Please refer to this catalog under 400LXR Positioners or to the “SL Series” linear motor section on www.parkermotion.com (Fig. 14 and 15).



Fig. 14: SL Series Slotless Linear Motors



Fig. 15: 404LXR Slotless Linear Motor Positioning System

3.0 Guide Systems

Even though a linear motor system lacks the rotary transmission components of traditional positioning systems, the user is still required to provide some sort of linear guide / bearing. Typically, a linear bearing must be selected based on high speed and acceleration capability, long service life, high accuracy, low maintenance costs, high stiffness, and low noise. Other considerations may include, for example, the site space available, the mounting accuracy (flatness, parallelism, inclination), and the thermal expansion.

Different guide systems are available to fulfill these requirements:

- Slide bearings (dry running or hydrodynamic)
- Hydrostatic bearings
- Aerostatic bearings (air bearings)
- Track rollers (steel or plastic roller wheels)
- Rolling-contact bearings (square rail, cross roller, or round rail)
- Magnetic bearings

In practice, slide bearings, rolling-contact bearings, and air bearings are the most popular. For applications with low demands on precision and load-bearing capacity, dry-running slide bearings may be a suitable option. Guide systems based on rolling-contact like square rail and cross roller bearings exhibit good stiffness and excellent load-bearing capability. In addition, they offer excellent straightness and flatness over the length of travel. Air bearings offer the ultimate in performance. With practically no limits to max speed and acceleration and virtually no breakaway forces, air bearings are the best solution for ultra-high precision applications.

4.0 Servo Control and Feedback

Linear motors can offer the ultimate in high precision and motion dynamics. However, overall system performance is dependent on other components – particularly the servo controller and feedback mechanism used. In this section, we will examine how linear motors are commutated, how their position is sensed, and how it is important to have an adequate controller to optimize system performance.

Figure 16 shows the traditional cascaded structure of servo motor control. The same structure can be applied to linear motors. One advantage is that the position sensor can typically be located right at or closer to the load, thus improving the overall accuracy of the system.

One drawback is that the lack of a traditional mechanical transmission results in the effects of external forces being significantly greater. For this reason, the quality of the position signal (resolution and accuracy) and the performance of the servo controller (sampling time, trajectory update, and control algorithms used) are of prime importance in determining the degree of “positional stiffness” that can be achieved.

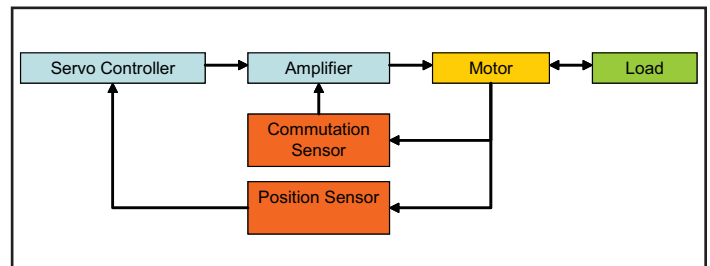

Fig 16(a): Servo Motor Control (position sensor located at motor)

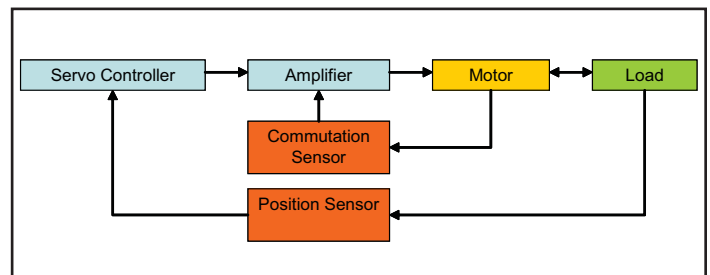

Fig 16(b): Servo Motor Control (position sensor located at load)

4.1 Commutation of the motor

In traditional rotary servo systems, it is important for the amplifier to know the position of the rotor. This way it can properly switch current through the motor phases in order to achieve the desired rotation of the shaft. Many times, three digital Hall effect sensors (spaced 60 degrees or 120 degrees apart) are used in order to provide positional information of the shaft within 6 states.

The same principle applies to linear motors. The amplifier must know the position of the forcer in relationship to the magnet rail in order to properly switch the windings. Rather than aligning the Hall effect devices (HEDs) within one complete revolution of the shaft, the Halls are matched to the magnetic pole pitch of the motor. The “pole pitch” is the linear distance traveled within one electrical cycle of the motor and is analogous to one revolution of a rotary motor.

Once the amplifier establishes the position of the forcer within the electrical cycle, it will then switch the motor phases whenever a transition occurs in the Hall states. This is known as *trapezoidal commutation*.

In most modern servo amplifiers, the position of the forcer need only be determined upon power up and enabling of the drive. Once the initial position is recognized, the drive can commutate off of the position sensor, which provides significantly higher resolution feedback than the digital HEDs. This allows the motor to be sinusoidally commutated. Sinusoidal commutation provides a smoother switching sequence resulting in less disturbances and less heat.

Another method of sinusoidal commutation is through the use of analog Hall effect devices. Analog Halls produce a sinusoidal signal as they pass over the magnetic poles of the magnet track. Analog Halls have also been used as an inexpensive method of providing positional feedback as well as commutation feedback. However, these devices are susceptible to picking up noise which can affect commutation – which in turn, affects smoothness of travel.

In some applications, HEDs are not desired – either from a cost savings standpoint, reduced wiring / component count, or other application specific standpoint. However, the servo drive must still be able to recognize the position of the motor forcer. In this case, **automatic commutation** can be achieved with a properly equipped servo drive. **Parker’s Compax3** drive/control has an “auto-commutation with test movement” function that automatically establishes the commutation angle. In this system, the Compax3 applies a test signal which induces small movements in the motor upon power up. The physical size of these movements can be quite small – as small as 10 electrical degrees (less than 2 mm on many linear motors), so there is no need to worry about the motor “*jumping*.” In addition, the test signals are “softened” such that system jerk is minimized.

4.2 Positional Feedback

There are a variety of methods to provide linear positional feedback to the motion controller. There are analog transducers, rack-and-pinion style potentiometers, and laser interferometers, to name a few. Each has its own level of accuracy and cost. But far and away the most popular feedback device for linear motor positioning systems is the linear encoder.

Most linear encoders provide an incremental pulse train that provides discrete “counts” back to the motion controller as the encoder “read head” moves along a “linear scale.” Typically, the read head is mounted close to the load and the linear scale is applied to the positioner base. There are two popular styles of linear encoders – optical and magnetic.

Optical encoders use reflected light scanning techniques to provide feedback with extremely high resolution and accuracy. Optical encoders are capable of providing feedback in the nanometer resolutions. Magnetic encoders use inductive scanning techniques to offer significantly more economical feedback, but have considerably lower accuracy and resolution. Magnetic encoders can typically offer resolutions down between the 1 to 5 micron range.

A third variation of linear encoder is the Sine encoder. The Sine encoder produces analog sine and cosine signals instead of discrete pulses. Many modern motion controllers have the ability to interpolate these analog signals into extremely fine resolutions. For example, the Compax3 controller can interpolate a 1 Vpp signal into 14 bits, i.e., the sine/cosine signal period is divided into 16,384 counts. A typical pitch period of a Sine encoder is 1mm, thus the resolution can be interpolated down to 62 nm in the controller.

All of these encoders provide incremental positioning information. Hence, it is necessary to establish a *home position* any time positional information is lost by the controller, i.e., power down. In some applications it is necessary to have *absolute feedback* where the actual position of the motor is known immediately and no homing sequence is required. Some encoder manufacturers are now making absolute linear encoders that transfer data using a synchronous serial interface (SSI). Parker’s **Aries** family of servo drives support absolute feedback transmitted via SSI. Please contact your Parker representative for further details.



Fig. 17: Parker ACR Controller and Aries Drives

When using linear encoders it is critically important to have proper mounting of the scanner (read) head. Inadequate mounting may cause mechanical resonance effects and errors in the measured position caused by vibration of the sensor head. In this case, the achievable bandwidth of the control loop – and hence, the maximum positioning stiffness – is reduced considerably. In some cases, large gaps of positional information are lost entirely, rendering the system totally inaccurate.

If the linear scale is not aligned straight with the guide bearings, accuracy can be affected in the form of “cosine errors.” (Fig. 18) shows a representation of how linear encoder scale misalignment can cause cosine errors.

The actual distance traveled will be L , where $L = L_{enc}(\cos\Theta)$. The size of the error will be $error = L_{enc}(1 - \cos\Theta)$. Thus, it is important to pay attention to the mounting of the read head as well as providing robust attachment and accurate alignment of the linear scale.

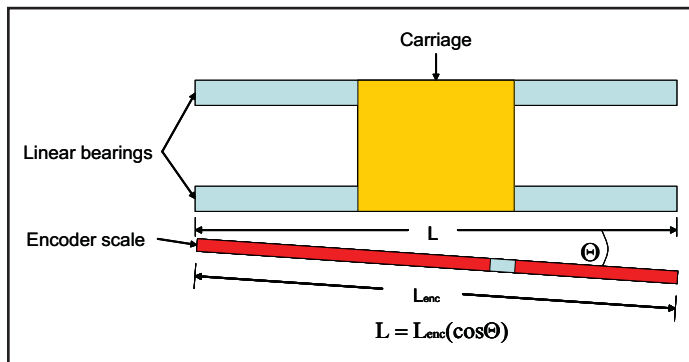

Fig. 18: Cosine errors caused by encoder scale misalignment

4.3 Servo Control –

Due to the direct drive nature of linear motors, there are no intermediate mechanical components or gear reductions to absorb external disturbances or shock loading. As a result, these disturbances have a significantly greater impact on the control loop than they would when using other technologies. For this reason, it is extremely important to have a controller with fast trajectory update rates. In addition, it is important to have a controller which allows you manipulate “feedforward” control of speed, acceleration, and jerk. These parameters allow the user to minimize tracking errors during acceleration, deceleration, and during external disturbances.

By defining parameters like jerk within your move profile, the tracking accuracy of highly dynamic moves can be improved, stresses on the mechanical system can be reduced, and excitation of mechanical resonances can be minimized. In addition, payloads that must be handled gently can still have optimized move profiles with the implementation of jerk-limited setpoint generation. Parker’s **ACR** and **Compax3** families of controllers allow optimization of all feedforward parameters and provide extremely fast trajectory update rates for superior control of linear motors.

Another common control challenge of linear motor systems is the control of gantry robots. Unlike belt- and screw-driven gantries where the transmissions of parallel axes can be mechanically connected, linear motor gantries have no mechanical coupling whatsoever. If tight control is not provided between these axes, binding and mechanical damage can occur. Traditional “master – follower” control schemes do not work well with gantries because the follower axis can bind but the master axis will be unable to recognize it.

Parker’s **ACR** series of controllers have a *gantry lock function* which provides skew compensation for gantry systems. By locking the feedback of each axis into the servo loop of the other, perfect coordination between axes is established to prevent binding and mechanical damage.

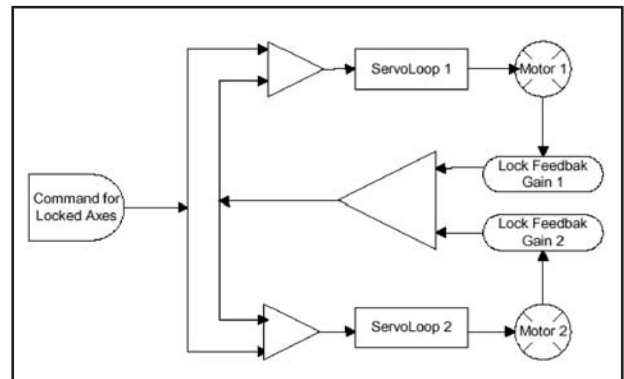

Fig. 19: Parker's ACR Controller Gantry Lock Feature

5.0 Packaged Linear Motor Positioners

As we have learned here, there are a lot of elements that affect precision in a linear motor system. Accuracy is affected by the bearing technology, structural stability, mounting and precision of the feedback system, and the capabilities of the controller. In addition, other variables such as mechanical stiffness and vibration can play a large part in the overall error budget of a machine.

As a result, it takes a reasonable amount of expertise to integrate all the components into a precision linear motor system. Many machine builders and laboratory equipment users tend to have expertise in their particular processes rather than in the integration of components. In addition, many systems integrators do not have the time to model, analyze, and implement linear motor designs.

For these reasons, several designers have chosen to purchase pre-packaged, pre-engineered linear motor positioners. By leaving the design and integration work to their vendors, they can deliver cost effective precision motion control solutions to their customers in an extremely short time to market. Components are performance matched for fast response, high acceleration, smooth translation, high velocity, and quick settling time. In addition, positioners can have a variety of flexible connectorization options, cable tracks, and mounting options – including multi-axis compatibility.

Parker offers a variety of packaged linear motor positioners to fit most any application.

- Industrial-grade positioners for high force, high motion dynamics, and high precision
- Precision-grade positioners for extremely high positional accuracy
- Miniature precision-grade positioners for lab automation, photonics, electronics and other applications requiring high accuracy in a small form factor



Fig. 20: MX80L Miniature Linear Motor Stage

6.0 Linear motors compared against other technologies

It has been well established that linear motors offer the ultimate in high dynamics and high precision. However, many machine builders have cost sensitive budgets and will often look to common rotary-to-linear technologies to solve their positioning needs. This section will take a hard look at these competing technologies and will show the long-term benefits switching to linear motors.

6.1 Belt Drives

Belts and pulleys are the workhorses of the automation world. They provide high speeds and reasonable positioning repeatability for an economical component cost. But there are inherent limitations to using belt drives. A belt drive system will typically consist of the following components:

- High tensile strength belt
- Pulleys
- Gearbox, for inertia matching
- Motor and coupling
- Carriage attached to belt
- Roller bearings or slider element

All the torsional windup, backlash, and belt stretching of these components contribute to inaccuracies in the system. Typical repeatability of a belt drive system is around ± 0.2 mm whereas repeatability for a common linear motor system can be $\pm 1\mu$. Even then, the belts must be optimally tensioned and the bearings preloaded. Also, the feedback is connected to the motor and not the load. This contributes to even further inaccuracies in the system.

Additionally, all of these components are “spring like” by nature and cause ringing and delays in settling time. So while belt drive systems can operate at high speeds, they can be difficult to tune for dampening and quick settling. This problem only gets worse at longer lengths, as belts tend to sag the longer they have to span. Eventually, the belt drives become limited in how long they can travel due to the unavoidable sag.

Finally, belt-driven systems can be maintenance intensive. Belts can lose tensioning over time and even skip teeth. Sliding bearings can break down. Couplings can slip or be misaligned. All of these problems force the user to shut down valuable production time in order to maintain the actuator.

Linear motors, by their direct-drive nature, are virtually maintenance free. As long as the bearings are properly lubricated, there is little else to do in order to maintain the positioner. Because all of the mechanical transmission components are gone, linear motor positioners do not suffer from torsional windup, backlash, belt stretch, or settling problems. They are extremely responsive and settle extraordinarily quick. They can match or exceed the acceleration and speed characteristics of a belt drive while positioning far more accurately. Finally, there are no limitations as to how long a linear motor travels. The dynamic performance stays exactly the same, no matter what the distance traversed.

6.2 Screw Drives

Screw driven positioning systems are very common for relatively high-precision positioning applications. They are cost-effective and offer varying degrees of precision depending on the needs of the application. A screw-driven system typically consists of the following components:

- Ballscrew or leadscrew that is precision ground or rolled
- Ball nut or sliding nut
- Motor
- Motor block and coupling
- Carriage
- Linear guide – typically square rail, cross roller, or round rail

Leadscrews are typically inefficient, less than 50% in most cases. While they are cost effective, the nut tends to wear due to friction. In addition, the accuracy and repeatability can suffer with leadscrews as most are not precision ground. Ballscrews, approaching 90% efficiency, come in precision ground or rolled packages. However, they still wear over time, suffer from torsional windup, and have a tendency to exhibit backlash. These problems factor into lost precision and slower settling times. In both cases, speeds are limited by the thread pitch and the length of the screw. As screws become longer, they tend to “whip” at higher speeds. Thus, they come nowhere near the speed and acceleration capabilities of linear motors. Eventually, there comes a point where screws become so long, they are difficult and unwieldy to manufacture.

Finally, like belt drives, screw-driven systems must be maintained. Eventually nuts wear, couplings slip, and screws need to be replaced - again, shutting down production and costing the user valuable time and money.

Since linear motor positioners have no intermediate mechanical transmissions, they do not suffer from the drawbacks of screw drives. In addition, they are not limited by length or by the dynamic performance related to length. One drawback to linear motors is that they are not inherently sufficient for vertical applications that require braking. Typically, this problem can be overcome by adding a pneumatic, spring-based, or weight-based counterbalance.

6.3 Comparing Costs

In most cases, the upfront cost of purchasing a linear motor system will be more expensive than belt- or screw-driven systems. However, in certain cases the cost can be similar or even less. Many machine builders requiring an extra degree of accuracy will buy a precision-ground ballscrew and add linear encoder feedback. Typically, the added cost of these components will drive the overall cost of the positioner to be higher than that of a linear motor system. In addition, improved manufacturing methods and increased volumes are driving down the cost of linear motors. Over time, users will see the price gap close dramatically. Finally, when comparing the overall cost of ownership (factoring in maintenance and down time), linear motors become considerably less expensive.

7.0 The Future of Linear Motors

The field of linear motors will develop dynamically in the future. As costs continue to fall and as innovations continue to rise, more and more industries will begin to adopt linear motor technology. Their high dynamics, high precision, and virtually maintenance-free operation will appeal to traditional users of rotary-to-linear transmissions.

In the early days of linear motors, only the high-tech industries like semiconductor and electronics adopted the technology. Eventually, industries like machine tool latched on to the inherent benefits of direct drives and now account for nearly 1/3rd of all linear motor sales. Now we are seeing new markets like material handling, packaging, medical, and food processing begin to switch out the belts, screws, and even pneumatics for linear motors. All of these new customers are beginning to push the technology to a critical mass and widespread acceptance. Indeed, it looks like linear motors will be making a breakthrough impact on the entire world of manufacturing.

EM Sales Offices

Australia

Parker Hannifin (Australia)
Pty Limited
9 Carrington Road
Castle Hill NSW 2154
Australia
Tel: +61 (0) 2 9842 5160
Fax: +61 (0) 2 9634 3749

Brazil

Parker Hannifin Ind. Com Ltda.
Av. Lucas Nogueira Garcez 2181
Esperança
12325-900 Jacareí, SP
Tel: 12 3954 5100
Fax: 12 3954 5262
automation.brazil@parker.com

China

**Parker Hannifin Motion & Control
(Shanghai) Co., Ltd**
280 Yunqiao Rd, Jin Qiao Export
Processing Zone
Shanghai 201206, China
Tel: (86-21) 50312525
Fax: (86-21) 64459717

France

Parker SSD Parvex
8 avenue du Lac
B.P. 249
F-21007 Dijon Cedex
Tel: +33 (0) 3 80 42 41 40
Fax: +33 (0) 3 80 42 41 23

India

Parker Hannifin India Pvt. Ltd.
EL-26, TTC, Industrial Area.
Mahape, Navi-Mumbai. -400 709.
Tel: 0091 22 65137081 85, 65137050-03
Fax: 0091 22 27686841, 27686618

Italy

**Parker Hannifin SpA
(SSD Drives Division)**
Via Gran Sasso, 7
20030 Lentate sul Seveso -
MI - Italy
Tel: +39 0362 557308
Fax: +39 0362 557312

Korea

Parker Hannifin Korea
6th Floor Daehwa Building
169 Samsung-dong Kangnam-gu
Seoul 135-882, South Korea
Tel: +82 2 559 0400
Fax: +82 2 556 8187

Scotland and Northern Ireland

Unit 59
Stirling Enterprise Park
Player Road
Stirling FK7 7RP
Tel: +44 (0) 1786 471674
Fax: +44 (0) 1786 451095

Singapore

**Parker Hannifin
Singapore Pte Ltd**
11, Fourth ChinBee Road
Singapore 619702
Tel: (65) 6887 6300
Fax: (65) 6265 5125/6261 4929

Singapore Pte Ltd (Branch Office)

Lot 558A, Jalan Subang 3
Off Persiaran Subang
Sungai Penaga Industrial Park
47610 Subang Jaya Malaysia
Tel: (60) 03 5638 1476
Fax: (60) 03 5638 1527

Taiwan

Parker Hannifin Taiwan Co., Ltd
No. 40, Wuchuan 3rd Road
Wuku Industrial Park
Taipei County, Taiwan 248
ROC
Tel: 886 2 2298 8987
Fax: 886 2 2298 8982

Thailand

Parker Hannifin (Thailand) Co., Ltd.
1023, 3rd Floor, TPS Building,
Pattanakarn Road,
Suanluang, Bangkok 10250
Thailand
Tel: (66) 02717 8140
Fax: (66) 02717 8148

UK

Parker Hannifin (Main Office)
New Courtwick Lane
Littlehampton
West Sussex BN17 7RZ
United Kingdom
Tel: +44 (0) 1903 737000
Fax: +44 (0) 1903 737100

Germany

**Electromechanical Europe
Parker Hannifin GmbH & Co KG**
Robert-Bosch-Strasse 22
D-77656 Offenburg
Germany
Tel: +49 (0) 781 509 0
Fax: +49 (0) 781 509 98176

USA

**Parker Hannifin
Electromechanical Automation Division Main
Office/Compumotor**
5500 Business Park Drive
Rohnert Park, CA 94928 USA
Tel: 707-584-7558
800-358-9070
Fax: 707-584-8015
Email: emn_support@parker.com

**Parker Hannifin
Electromechanical Automation
Division/CTC**
50 West TechneCenter Dr.
Milford, OH 45150
Tel: 513-831-2340
800-233-3329
Fax: 513-831-5042
Email: emn_moreinfo_ctc@parker.com

**Parker Hannifin
Electromechanical Automation
Division/Bayside**
27 Seaview Boulevard
Port Washington, NY 11050
Tel: 516-484-5353
800-305-4555
Fax: 516-629-8000
Email: emn_support_bayside@parker.com

**Parker Hannifin
Electromechanical Automation
Division/Daedal**
1140 Sandy Hill Road
Irwin, PA 15642
Tel: 724-861-8200
800-245-6903
Fax: 724-861-3330
Email: ddlicat@parker.com

Parker Hannifin Corporation
Electromechanical Automation
5500 Business Park Drive
Rohnert Park, CA 94928
Phone: 800.358.9068
Fax: 707-584-8015
Web site: www.parkermotion.com
www.trilogysystems.com

