

Direct Drive Motors

Motor Construction and Operation

Direct drive systems couple the system's load directly to the motor without the use of belts or gears. In some situations, brushed or brushless servo motors may lack adequate torque or resolution to satisfy some applications' needs. Therefore, mechanical means, such as gear reduction systems to increase torque and resolution, are used to meet system requirements. The Dynaserv Direct Drive can provide very high torque in a modest package size and solves many of the performance issues of the gear reducer. All in a system that is as easy to use as a stepping motor.

Fig. 1.45 below shows the construction of the Dynaserv DM Series direct drive motor compared to a conventional motor with a gear reducer. The gear reducer relies on large amounts of frictional contact to reduce the speed of the load. This gearing effectively increases torque and resolution but sacrifices speed and accuracy. The direct drive motor is brushless and gearless so it eliminates friction from its power transmission. Since the feedback element is coupled directly to the load, system accuracy and repeatability are greatly increased and backlash is eliminated.

Fig. 1.45 Construction comparison

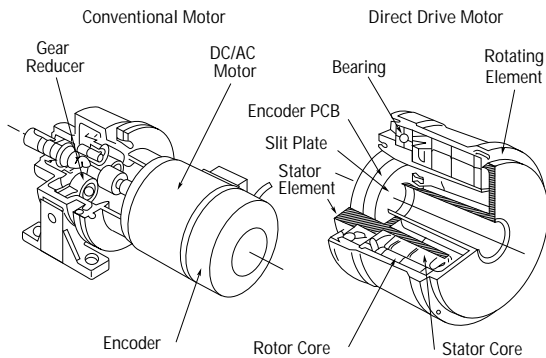

The motor contains precision bearings, magnetic components and integral feedback in a compact motor package (see Fig. 1.46). The motor is an outer rotor type, providing direct motion of the outside housing of the motor and thus the load. The cross roller bearings that support the rotor have high stiffness, to allow the motor to be connected directly to the load. In most cases, it is not necessary to use additional bearings or connecting shafts.

Fig. 1.46 Expanded motor view—
Dynaserv Model DM

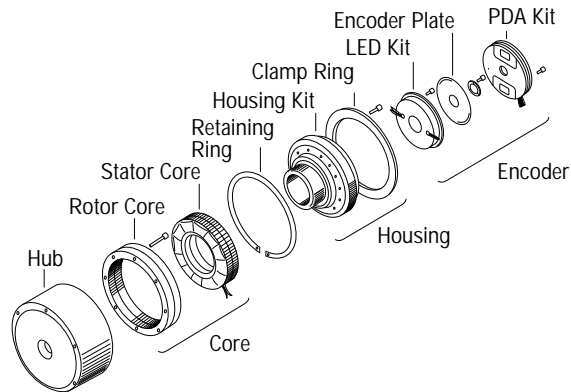

The torque is proportional to the square of the sum of the magnetic flux (Φ_m), of the permanent magnet rotor and the magnetic flux (Φ_s), of the stator windings. See Fig. 1.47. High torque is generated due to the following factors. First, the motor diameter is large. The tangential forces between rotor and stator act as a large radius, resulting in higher torque. Secondly, a large number of small rotor and stator teeth create many magnetic cycles per motor revolution. More working cycles means increased torque.

Fig. 1.47 Dynaserv magnetic circuit

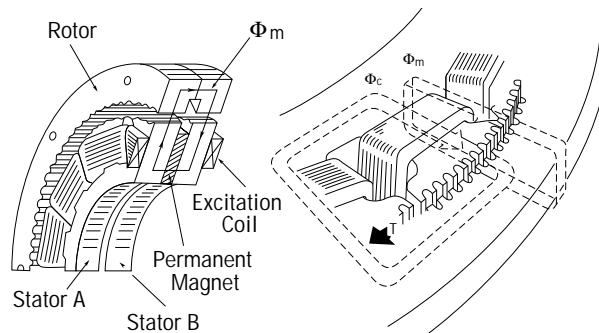

Direct Drive Motor Advantages

High Precision

Dynaserv motors eliminate the backlash or hysteresis inevitable in using any speed reducer. Absolute positioning of 30 arc-sec is typical with a repeatability of ± 2 arc-sec.

Faster Settling Time

The Dynaserv system reduces machine cycle times by decreasing settling times. This result is realized because of the "gearless" design and sophisticated "I-PD" control algorithm.

High Torque at High Speed

The torque/speed curve of the various Dynaserv models is very flat. This results in high acceleration at high speeds (4.0 rps) with good controllability.

Smooth Rotation

The very low velocity and torque ripple of the Dynaserv contribute to its excellent speed controllability with a more than 1:1,000 speed ratio.

Optimum Tuning

Dynaserv systems offer the user a tuning mode that simplifies the setting of optimum parameters for the actual load. Turning on the "test" switch on the front panel of the drive produces a test signal. Using an oscilloscope, the gain settings are quickly optimized by adjusting the digital switches and potentiometers on the front panel.

Clean Operation

The Dynaserv system is brushless and gearless, which results in a maintenance-free operation. With preparation, the Dynaserv can operate in class 10 environments.

Fig. 1.48 Dynaserv velocity/torque ripple

