



Bulletin PM-ER01/USA

Maintenance Instructions & Parts List

Effective: July 1, 2000



ER Series Rodless Actuator

Who's Who
ER Series Rodless Actuators
Voice (330)336-3511 - Fax (330)334-3335

Karen Dutt	Ext. 122	Order Entry & Expediting Technical Information
David Bugajski	Ext. 125	Applications, Spare Parts
Mark Fisher	Ext. 123	Programming
Ben Furnish	Ext. 128	
TBD	Ext. 124	Electro-Mechanical Product Sales Manager
Bill Service	Ext. 107	Marketing Manager
Roger Sherrard	Ext. 103	General Manager

 **WARNING**

FAILURE OR IMPROPER SELECTION OR IMPROPER USE OF THE PRODUCTS AND/OR SYSTEMS DESCRIBED HEREIN OR RELATED ITEMS CAN CAUSE DEATH, PERSONAL INJURY AND PROPERTY DAMAGE.

This document and other information from Parker Hannifin Corporation, its subsidiaries and authorized distributors provide product and/or system options for further investigation by users having technical expertise. It is important that you analyze all aspects of your application and review the information concerning the product or system in the current product catalog. Due to the variety of operating conditions and applications for these products or systems, the user, through its own analysis and testing, is solely responsible for making the final selection of the products and systems and assuring that all performance, safety and warning requirements of the application are met.

The products described herein, including without limitation, product features, specifications, designs, availability and pricing, are subject to change by Parker Hannifin Corporation and its subsidiaries at any time without notice.

Offer of Sale

The items described in this document are hereby offered for sale by Parker Hannifin Corporation, its subsidiaries or its authorized distributors. This offer and its acceptance are governed by the provisions stated on the separate page of this document entitled "Offer of Sale".

© Copyright 1997, Parker Hannifin Corporation, All Rights Reserved

Table of Contents

Description	Page No.
Product Overview	4, 5
Ordering Information	6, 7
Parts Lists and Exploded Views	
Actuators	9 - 15
Motor Mounts	16 - 21
Maintenance	
Cleaning	22
Lubrication	22
Adjusting Timing Belt Tension	23
Motor Coupler and Pulley Spacing	24
Torque Specifications	25
Adhesives	25
Bearing Carriage Adjustments	26 - 30
Belt Drive Tensioning	30
Motor Information	
Step Motors	31 - 33
Brushless Servo Motors	34 - 35
DC Brush Motors	36 - 38
End of Travel and Home Sensor Information	39 - 40
Brake Option	41
Offer of Sale	43

Product Information**ER Series Rodless Actuator****Product Introduction and Features**

The ER Series Rodless Actuator combines a robust, modular design with a variety of options that allow it to be tailored to many applications. With two load bearing carriage styles available on all actuator sizes and two drive types (belt and screw drive), the ER Series may be ordered specifically designed for the application. Combined with a Parker Hannifin stepper, servo or DC brush system, the ER Series becomes a fully programmable linear actuator system.

ER Series Features

- Produced to hard metric ISO standards
- Three ISO mount sizes: 32mm, 50mm, 80mm
- Standard roller bearing carriage
- Square rail carriage option for greater load carrying capability
- Extruded, anodized aluminum body with t-slots for mounting switches and clamps
- Angular contact thrust bearings at rear of screw
- Polyurethane bumper at ends of travel
- Low-friction ball bearing nut and quality rolled ball screw option
- Low-friction burnished lead screw with bronze nut option
- Steel reinforced polyurethane drive belt (belt drives only)
- Integral sensing magnet
- High quality flexible couplings
- High performance stepper, servo and DC brush motors
- Designed for multi-axis connectivity (available from the Automation Actuator Division)

Motor Systems

- Microstepping systems
- DC Brushless servo systems with encoder or resolver feedback
- *AutoDrive* DC brush limit switch controller systems
- User provided AC or DC motor systems

Features

ER Series Overview

The figures below represent the main components of an ER Series Linear Actuator.

Screw Driven Unit

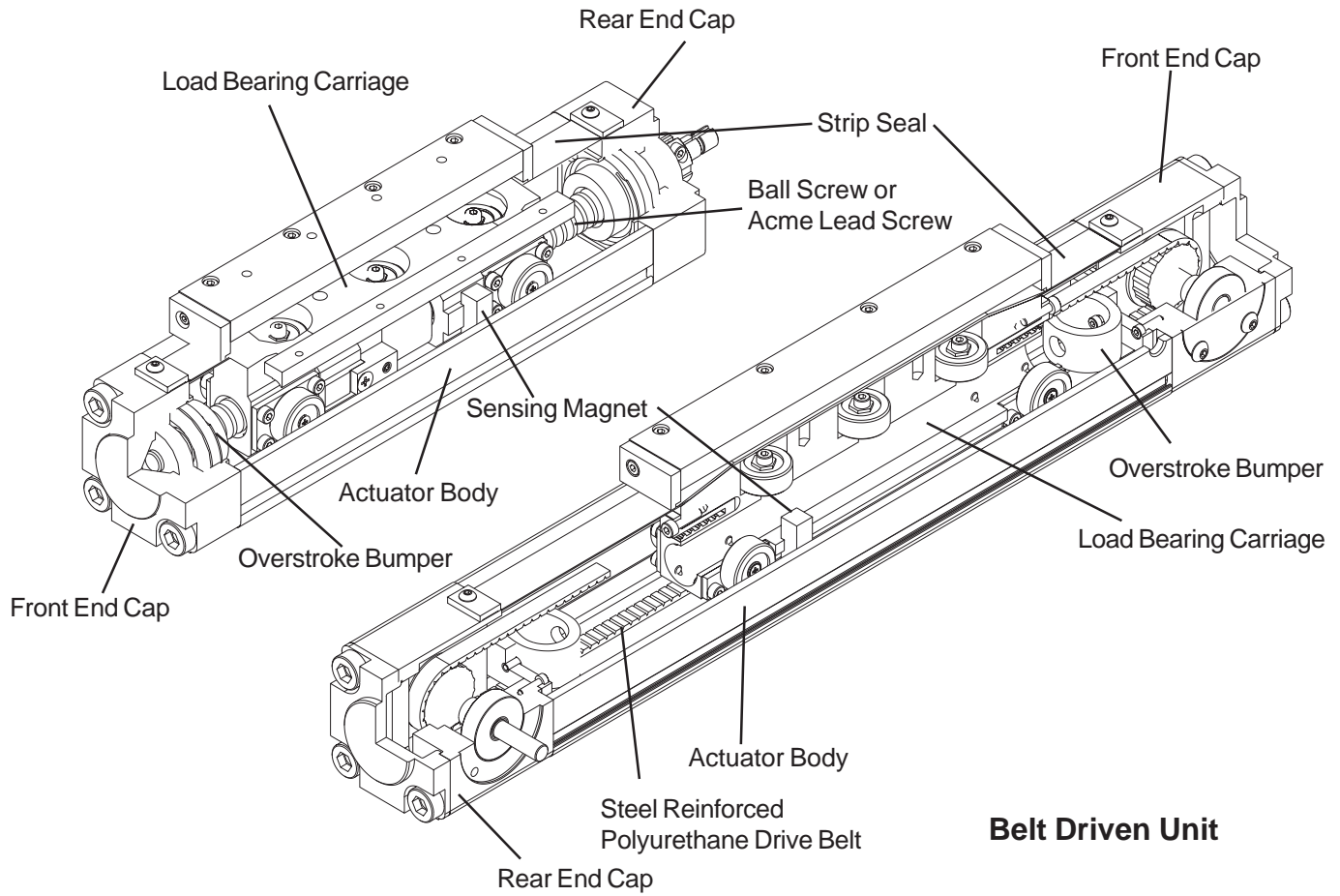

ERS - **50** - **B05** **R** **A** **21** -

Series/Motor Type
ERS Stepper
ERB Servo
ERD DC Brush

Profile Size
32 32 mm
50 50 mm
80 80 mm

Drive Type	Available Sizes
A04 Acme Screw, 0.250 in lead	ER32, 80
A05 Acme Screw, 0.200 in lead	ER50
A08 Acme Screw, 0.125 in lead	ER32
B01 Ball Screw, 1.000 in lead	ER50, 80
B02 Ball Screw, 0.500 in lead	ER50, 80
B04 Ball Screw, 0.250 in lead	ER80
B05 Ball Screw, 0.200 in lead	ER50
B08 Ball Screw, 0.125 in lead	ER32
BLT Belt Drive	All

Drive Ratio
(See Tables Below for Availability)
A 1:1 (Inline or Parallel)
B 1.5:1 (Parallel)
D 2:1 (Parallel)
Z 1:1.5 (Parallel, ER32 only)

Motor Mounting Style – Screw Drive	
L	Inline Motor Mounting
M	Parallel with Timing Belt, Motor Position 2
N	Parallel with Timing Belt, Motor Position 3
Q	Parallel with Timing Belt, Motor Position 4
R	Reverse Parallel with Timing Belt, Motor Position 1
S	Reverse Parallel with Timing Belt, Motor Position 2
T	Reverse Parallel with Timing Belt, Motor Position 3
V	Reverse Parallel with Timing Belt, Motor Position 4
Motor Mounting Style – Belt Drive	
R	Direct Drive, Drive Right
L	Direct Drive, Drive Left
M*	Parallel with Timing Belt, Over Right
N	Parallel with Timing Belt, Under Right
S*	Parallel with Timing Belt, Over Left
T	Parallel with Timing Belt, Under Left
V	Reverse Parallel with Timing Belt, Over Right
W	Reverse Parallel with Timing Belt, Under Right
Y	Reverse Parallel with Timing Belt, Over Left
Z	Reverse Parallel with Timing Belt, Under Left
J	Reverse Parallel with Timing Belt, Rear Right
K	Reverse Parallel with Timing Belt, Rear Left

* Not available with motor codes 2n for ERB32 and motor codes 6n and Jn for ERB50

Drive Ratio Availability
Step Motors and DC Brush Motors

Size	Drive Ratio			
	1:1	1:1.5	1.5:1	2:1
ERS/D32	2	2	—	—
ERS/D50	2 & 3	—	2 & 3	2
ERS/D80	3 & 4	—	3 & 4	3

Step Motor and DC Brush Motor	
Frame Size	Option
2 NEMA 23 (ER32, ER50)	0 No Motor, Flange and Coupler/Pulley Only
3 NEMA 34 (ER50, ER80)	1 Std. Motor, Cable Grommet w/o Damper
4 NEMA 42 (ER80)	2 Std. Motor, Conduit Connector w/o Damper
9 Special	3 Std. Motor, Brad Harrison Connector, w/o Damper
	4* Std. Motor, Cable Grommet w/ Damper
	5* Std. Motor, Conduit Connector w/ Damper
	6* Std. Motor, Brad Harrison Connector w/ Damper
	9 Used w/Frame Size 9, Special Motor to be Mounted
	X Used with Frame Sizes 2, 3, 4, Other Parker Motor

* Step motors only.

Model Code

Maintenance Instructions and Parts List
ER Series Rodless Actuator

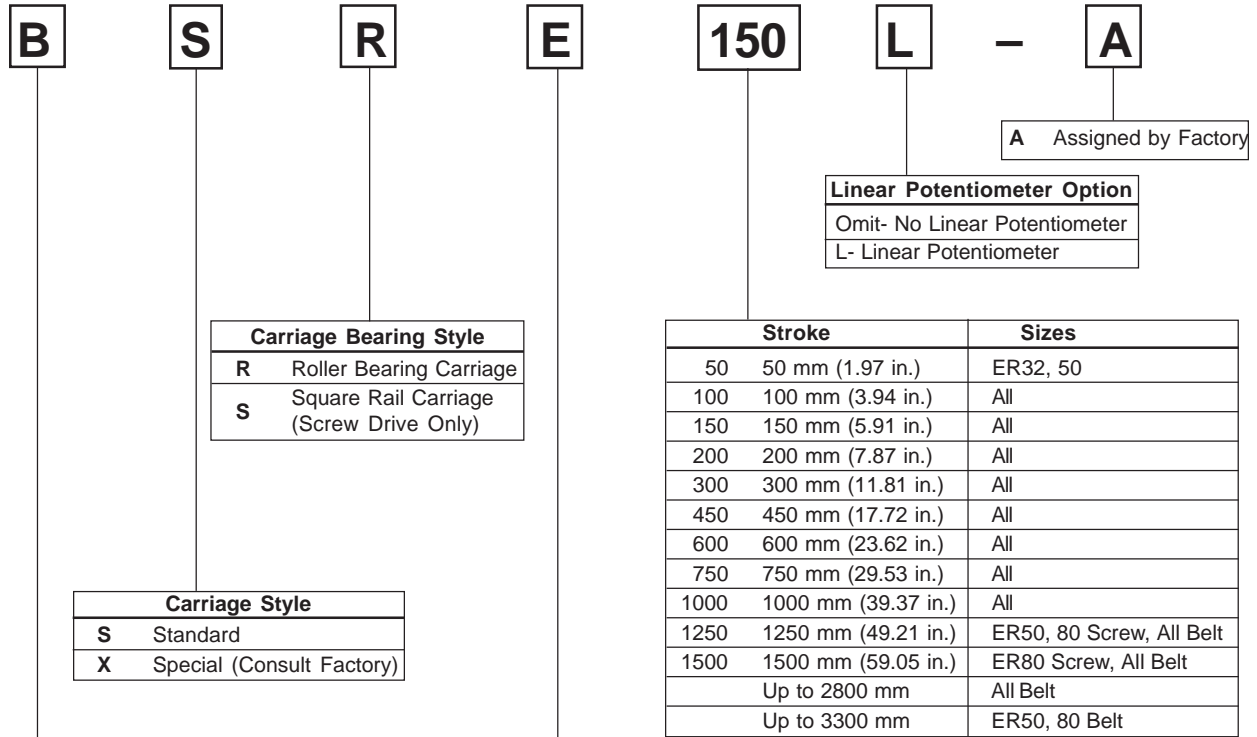

Carriage Style	
S	Standard
X	Special (Consult Factory)

Carriage Bearing Style	
R	Roller Bearing Carriage
S	Square Rail Carriage (Screw Drive Only)

Stroke		Sizes
50	50 mm (1.97 in.)	ER32, 50
100	100 mm (3.94 in.)	All
150	150 mm (5.91 in.)	All
200	200 mm (7.87 in.)	All
300	300 mm (11.81 in.)	All
450	450 mm (17.72 in.)	All
600	600 mm (23.62 in.)	All
750	750 mm (29.53 in.)	All
1000	1000 mm (39.37 in.)	All
1250	1250 mm (49.21 in.)	ER50, 80 Screw, All Belt
1500	1500 mm (59.05 in.)	ER80 Screw, All Belt
Up to 2800 mm		All Belt
Up to 3300 mm		ER50, 80 Belt

Actuator Mounting Options	
B*	Foot Mount (MSI)
E*	Rear Eye (MP4)
F	Bottom Tap (MS4) Standard
G	Foot Side Lug, Screw Drive Only
H*	Rear Flange (MF2) Screw Drive Only
J	Front Flange (MF1)
N*	Front and Rear Flange (MF1 and MF2) Screw Drive Only
X	Special

Brake Option (ER50, 80)	
Omit No Brake	
E¹	115 VAC with Flying Leads and Cable Gland
F¹	24 VDC with Flying Leads and Cable Gland
G¹	115 VAC with Brad Harrison Conn. and 4 m Cable
H¹	24 VDC with Brad Harrison Conn. and 4 m Cable
V²	115 VAC w/ Flying Leads, Cable Gland on Step Motor (NEMA 34,42)
W²	24 VDC w/ Flying Leads, Cable Gland on Step Motor (NEMA 34,42)
Y²	115 VAC w/ Brad Harrison Conn. and 4 m Cable on Step Motor (NEMA 34, 42)
Z²	24 VDC w/ Brad Harrison Conn. and 4 m Cable on Step Motor (NEMA 34,42)

* Parallel motor mounting only.

¹ Not available on inline screw drives or direct drive belt drives. Not compatible with rear mounting options (B, H, N).

² Not compatible with damper or encoder options.

Servo Motor		
Motor Code		Sizes
20	NEMA 23 Flange and Coupling/ Pulley Only	ER32, 50
22	SM233BE-TTQN Motor with 10 ft. Cables	ER32, 50
23	SM233BR-TMSN Motor with 10 ft. Cables	ER32, 50
2X	Other Parker NEMA 23 Motor to be Mounted	ER32, 50
30	NEMA 34 Flange and Coupling/ Pulley Only	ER50, 80
3X	Parker NEMA 34 motor to be Mounted	ER50, 80
60	Parker 92 mm Flange and Coupler/Pulley Only	ER50, 80
6X	Other Parker 92mm Motor to be Mounted	ER50, 80
J1	J0922JR-KMSN with 25 ft. Cables	ER50, 80
J2	J0923HR-KMSN with 25 ft. Cables	ER50, 80
J3	J0923KR-KMSN with 25 ft. Cables	ER80
90	Special Flange and Coupler/ Pulley Only	Any
99	Special Motor to be Mounted	Any

Drive Ratio Availability Servo Motors

Size	Drive Ratio		
	1:1	1:1.5	1.5:1
ETB32	22 & 23	22 & 23	—
ETB50	22 & 23 J1/J2	—	22 & 23
ETB80	J1/J2/J3	—	J1/J2/J3

ER Series Form Factors

The ER Series Rodless Actuator is available in three basic form factors, each of which carries a separate exploded view drawing and parts list. After determining your ER form factor, refer to the parts list section corresponding to that form factor.

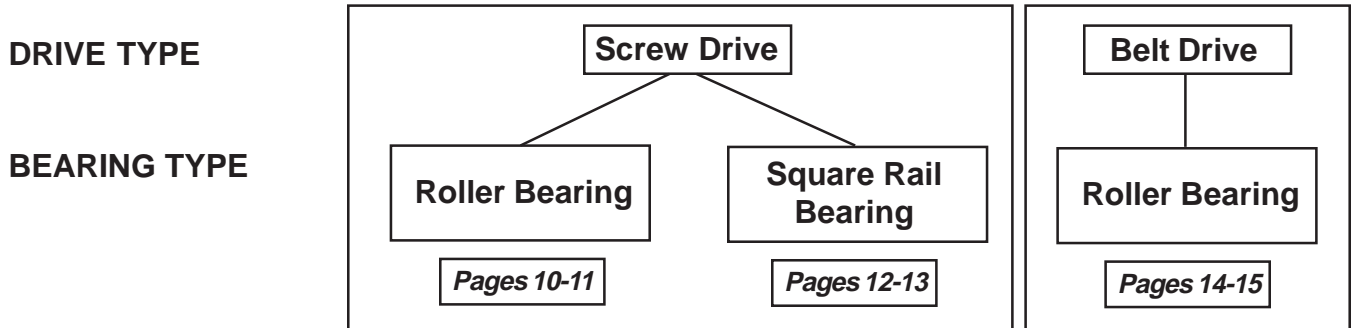

Motor Mounting Styles

The ER Series Rodless Actuator includes pre-mounted DC stepper, brushless servo or brush motors. Motors may be mounted inline, or directly coupled to the screw shaft (screw drive) or pulley shaft (belt drive). Alternatively, motor may be mounted in a variety of parallel (or reverse-parallel) configurations. Parallel mounting link the motorshaft and actuator drive shaft through a timing belt and pulley system. Refer to the model code pages (pp. 6-7) and Catalog 1894, *Electromechanical Actuator Products*, for a detailed description of the many mounting possibilities. Each motor mounting assembly may be applied to all ER Series types: screw and belt drive, roller bearing and square rail.

MOTOR MOUNTING TYPE



¹ Parts listed on page 13.

Exploded View- Roller Bearing/Screw Drive ER Series Rodless Actuator

ER Series Roller Bearing Carriage and Screw Drive

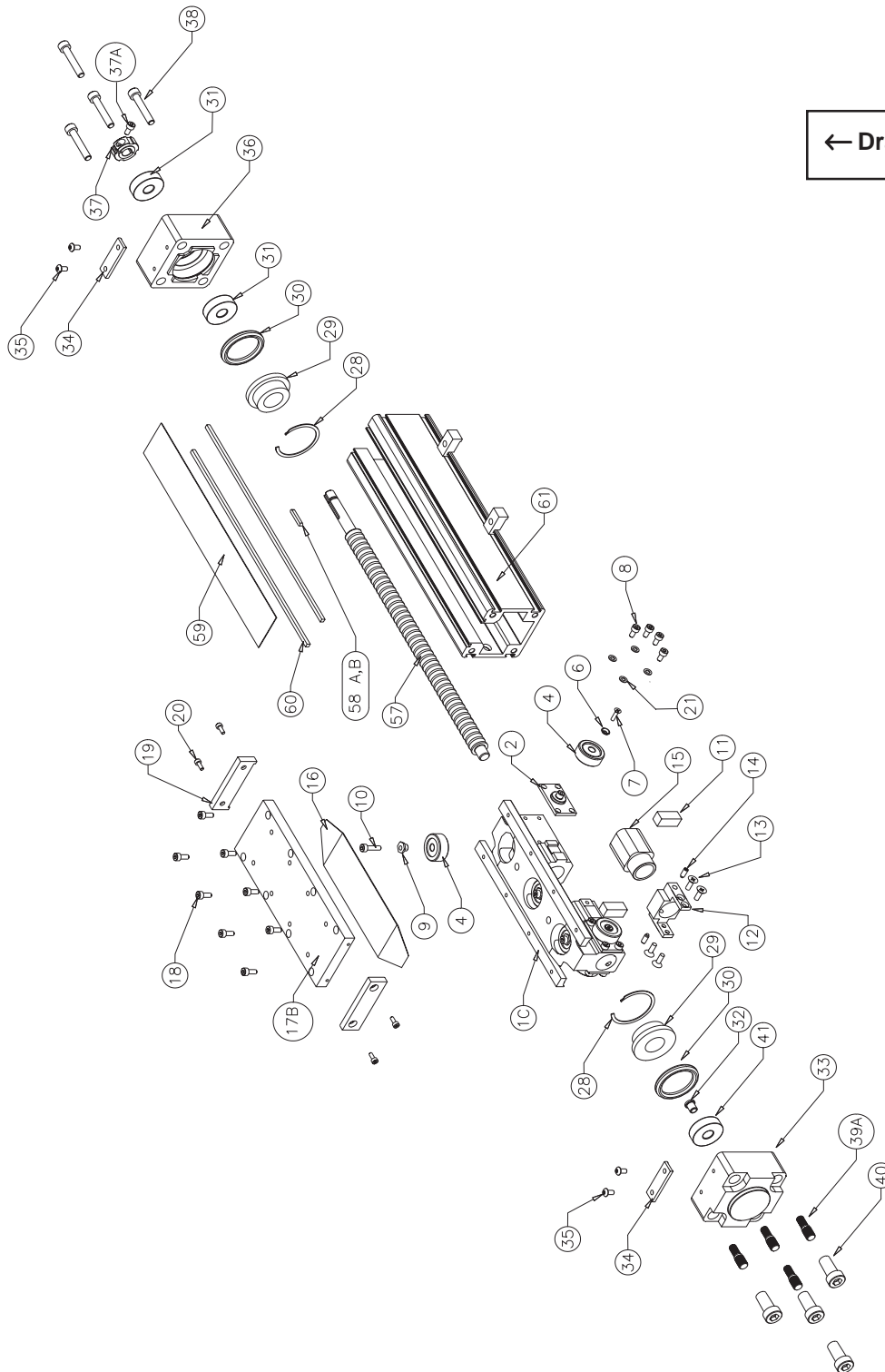

Parts List-Roller Bearing/Screw Drive

PART	DESCRIPTION	QTY	32	50	80
1C	CARRIAGE BODY, ROLLER	1	ER32R03RS	ER50R03RS	ER80R03RS
2	ROLLER PLATE	4	ER32R10	ER50R10	ER80R10
4	ROLLER WHEEL ASSEMBLY	7	ER32RCA	ER50RCA	ER80RCA
6	BEARING RETAINER	4	ET32R04	ET32R04	ET80R04
7	BEARING RETAINER SCREWS	4	CFT-CM3X0.5-008	CFT-CM3X0.5-008	CF-CM6X1.0-016
8	ROLLER PLATE BOLTS	16	CS-CM3X0.5-006	CS-CM4X0.7-008	CS-CM5X0.8-016-Z
9	ECCENTRICS	3	ER32R12	ER32R12	ER80R04
10	TOP ROLLER SCREWS	3	CB-CM4X0.7-012	CS-CM4X0.7-016	CS-CM6X1.0-020
11	SWITCH MAGNETS	2	ER32M10	ER80M10	ER80M10
12	NUT RETAINER	1	ER32R07	ER50R07	ER80R07
13	NUT RETAINER SCREWS	4	CF-CM4X0.7-012	CF-CM4X0.7-012	CF-CM6X1.0-020
14	NUT RETAINER SET SCREWS	2	SB-CM4X0.7-006	SB-CM6X1.0-008	SB-CM81.25-010
15	ACME/BALL SCREW NUT	1	TNXXXXXX	TNXXXXXX	TNXXXXXX
16	U.H.M.W. COVER SLIDE	1	ER32R14BSC	ER50R14BSC	ER80R14BSC
17B	TOP LOAD PLATE (SCREW)	1	ER32R05-S	ER50R05-S	ER80R05-S
18	TOP LOAD PLATE SCREWS	8	CS-CM3X0.5-010-Z	CS-CM4X0.7-012-Z	CS-CM5X0.8-016-Z
19	STRIP GUIDES	2	ER32R06	ER50R06	ER80R06
20	STRIP GUIDES SCREWS	4	CS-CM3X0.5-008-Z	CS-CM4X0.7-008-Z	CS-CM4X0.7-010-Z
21	SERRATED WASHER	16	B2124	B2125	B2115
28	END CAP SNAP RINGS	2	BNV-H-112	BNV-H-162	BNV-H-275
29	CARRIAGE STOPS	2	ER32M02	ER50M02	ER80M02
30	SCREW DRIVE END CAP BUMPERS	2	ET32M01	ET50M01	ET80M01
31	THRUST BEARINGS	2	RA373	RA336	RA342
32	SCREW SHAFT SLEEVE	1	ER32R08	N/A	N/A
33	SCREW DRIVE OPP.SIDE END CAP	1	ER32E01	ER50E01	ER80E01
34	STRIP GUIDE CLAMP	2	ER32M05	ER50M05	ER80M05
35	STRIP GUIDE CLAMP SCREWS	4	CB-CM4X0.7-008-Z	CB-CM4X0.7-008-Z	CB-CM4X0.7-008-Z
36	SCREW DRIVE MOTOR SIDE END CAP	1	ER32E02	ER50E02	ER80E02
37	BEARING LOCKNUT	1	ET32R07	B8777	B8776
37A	BEARING LOCKNUT SCREW	1	CS-CM3X0.5-008	SUPPLIED	SUPPLIED
38	SCREW DRIVE END SHCS IN LINE	4	CS-CM5X0.8-030	CS-CM6X1.0-035	CS-CM8X1.25-050
39A	TIE ROD BOLTS	4	M6-M5-A	M8-M6-A	M10-M8-A
40	TIE ROD NUTS	4	32-27015	50-27015	80-27015
41	RADIAL BEARING	1	RA339	RA374	RA375
57	ACME/BALL SCREW	1	ERTSXXXXXNXXXXXX	ERTSXXXXXNXXXXXX	ERTSXXXXXNXXXXXX
58A	ACME/BALL SCREW KEY IN LINE	1	B8534M2-06	B8534M2-08	B8534M5-14
58B	ACME/BALL SCREW KEY PARALLEL	1	B8534M2-20	B8534M3-20	B8534M5-32
59	STRIP SEAL	1	ER32M06BSC	ER50M06BSC	ER80M06BSC
60	STRIP SEAL MAGNETS	2	ER32M11BSC	ER32M11BSC	ER32M11BSC
61	BODY	1	ER32CXXXX	ER50CXXXX	ER80CXXXX

ER Series Square Rail Carriage and Screw Drive

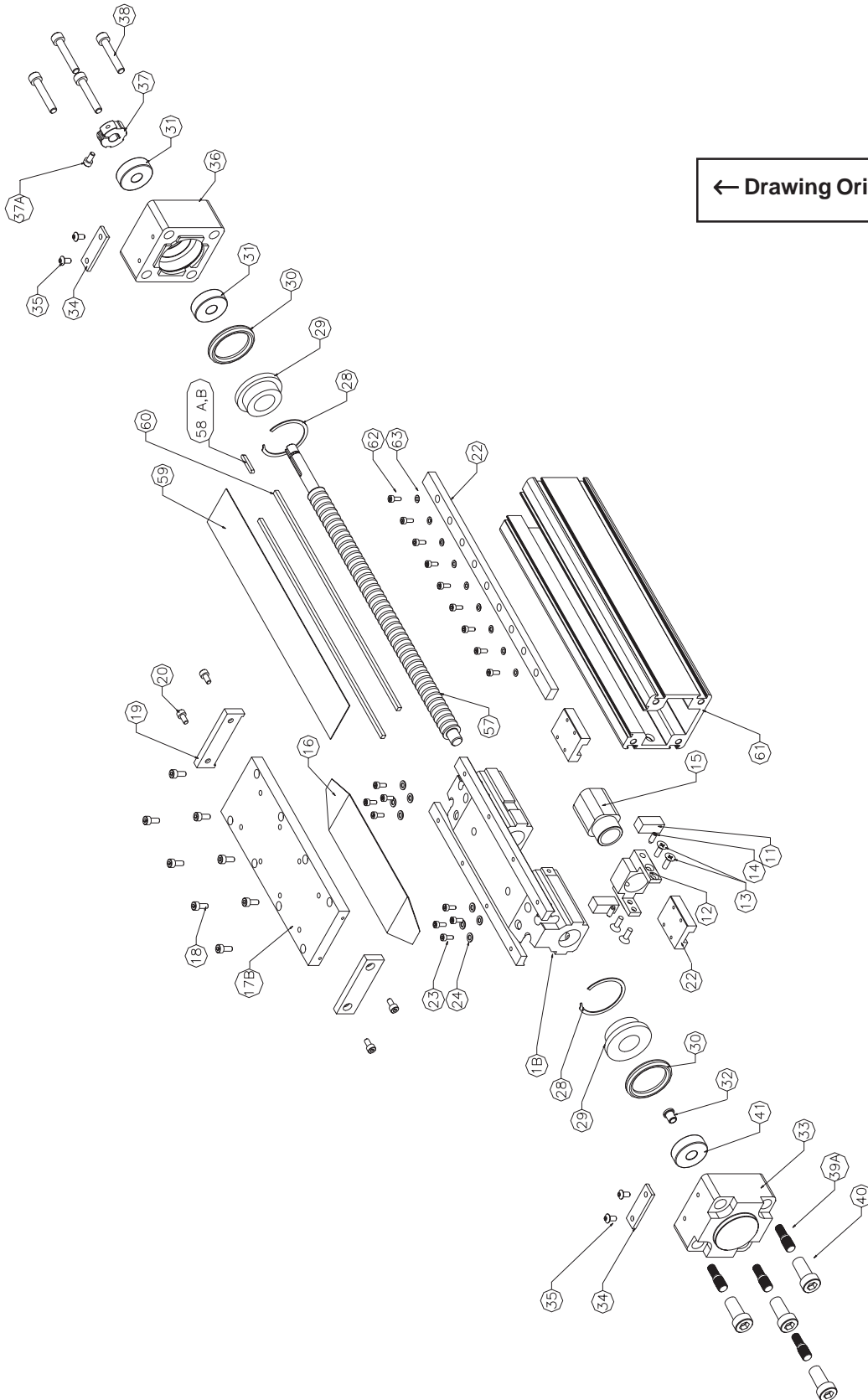

Parts List- Square Rail/Screw Drive

PART	DESCRIPTION	QTY	32	50	80
1B	CARRIAGE BODY, SQUARE RAIL	1	ER32R03SS	ER50R03SS	ER80R03SS
11	SWITCH MAGNETS	2	ER32M10	ER80M10	ER80M10
12	NUT RETAINER	1	ER32R07	ER50R07	ER80R07
13	NUT RETAINER SCREWS	4	CF-CM4X0.7-012	CF-CM4X0.7-012	CF-CM6X1.0-020
14	NUT RETAINER SET SCREWS	2	SB-CM4X0.7-006	SB-CM6X1.0-008	SB-CM81.25-010
15	ACMEBALL SCREWS NUT	1	TNXXXXX	TNXXXXX	TNXXXXX
16	U.H.M.W. COVER SLIDE	1	ER32R14BSC	ER50R14BSC	ER80R14BSC
17B	TOP LOAD PLATE (SCREW)	1	ER32R05-S	ER50R05-S	ER80R05-S
18	TOP LOAD PLATE SCREWS	8	CS-CM3X0.5-010-Z	CS-CM4X0.7-012-Z	CS-CM5X0.8-016-Z
19	STRIP GUIDES	2	ER32R06	ER50R06	ER80R06
20	STRIP GUIDES SCREWS	4	CS-CM3X0.5-008-Z	CS-CM4X0.7-008-Z	CS-CM4X0.7-010-Z
22	SQUARE RAIL BEARING SETS	1	RA377-XXXX	RA378-XXXX	RA379-XXXX
23	SQUARE RAIL BEARING SCREWS	8	CS-CM3X0.5-020	CS-CM3X0.5-008	CS-CM5X0.8-035
24	SERRATED WASHER	8	B2124	B2125	B2125
28	END CAP SNAP RINGS	2	BNVH-112	BNVH-162	BNVH-275
29	CARRIAGE STOPS	2	ER32M02	ER50M02	ER80M02
30	SCREW DRIVE END CAP BUMPERS	2	ET32M01	ET50M01	ET80M01
31	THRUST BEARINGS	2	RA373	RA336	RA342
32	SCREW SHAFT SLEEVE	1	ER32R08	N/A	N/A
33	SCREW DRIVE OPP.SIDE END CAP	1	ER32E01	ER50E01	ER80E01
34	STRIP GUIDE CLAMP	2	ER32M05	ER50M05	ER80M05
35	STRIP GUIDE CLAMP SCREWS	4	CB-CM4X0.7-008-Z	CB-CM4X0.7-008-Z	CB-CM4X0.7-008-Z
36	SCREW DRIVE MOTOR SIDE END CAP	1	ER32E02	ER50E02	ER80E02
37	BEARING LOCKNUT	1	ET32R07	B8777	B8776
37A	BEARING LOCKNUT SCREW	1	CS-CM3X0.5-008	SUPPLIED	SUPPLIED
38	SCREW DRIVE END SHCS IN LINE	4	CS-CM5X0.8-030	CS-CM6X1.0-035	CS-CM8X1.25-050
39A	TIE ROD BOLTS	4	M6-M5-A	M8-M6-A	M10-M8-A
40	TIE ROD NUTS	4	32-27015	50-27015	80-27015
41	RADIAL BEARING	1	RA339	RA374	RA375
57	ACME/BALL SCREW	1	ERTSXXXXXXXXXXXXX	ERTSXXXXXXXXXXXXX	ERTSXXXXXXXXXXXXX
58A	ACME/BALL SCREW KEY IN LINE	1	B8534M2-06	B8534M2-08	B8534M5-14
58B	ACME/BALL SCREW KEY PARALLEL	1	B8534M2-20	B8534M3-20	B8534M5-32
59	STRIP SEAL	1	ER32M06BSC	ER50M06BSC	ER80M06BSC
60	STRIP SEAL MAGNETS	2	ER32M11BSC	ER32M11BSC	ER32M11BSC
61	BODY	1	ER32CXXXX	ER50CXXXX	ER80CXXXX
62	SQUARE RAIL SCREWS	-	CS-CM3X0.5-006	CS-CM3X0.5-006	CS-CM4X0.7-016
63	SQUARE RAIL SCREW WASHERS	-	B2124	B2125	B2125

ER Series Roller Bearing Carriage and Belt Drive

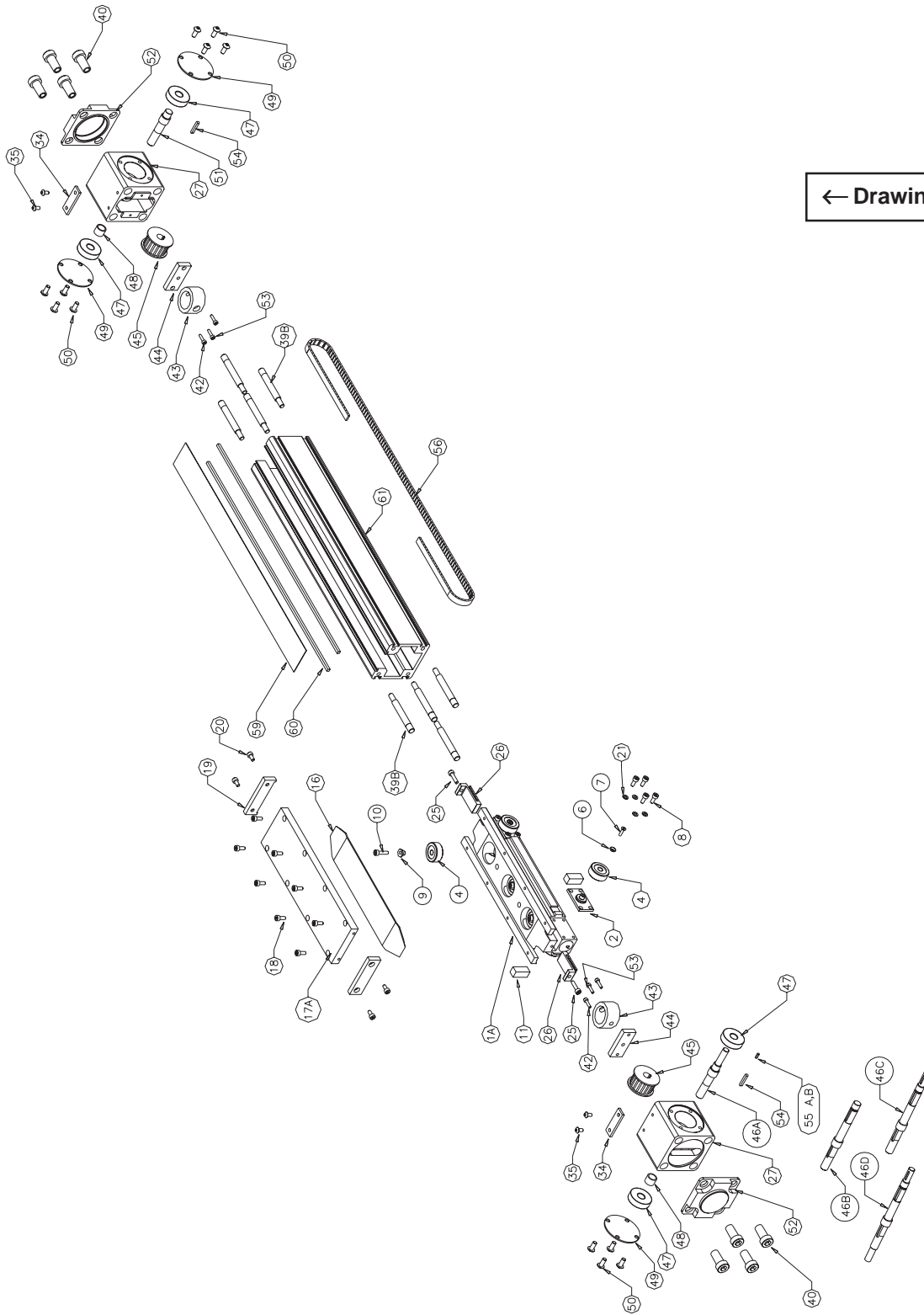

← Drawing Orientation

PART	DESCRIPTION	QTY	32	50	80
1A	CARRIAGE BODY, BELTED	1	ER32R03RB	ER50R03RB	ER80R03RB
2	ROLLER PLATE	4	ER32R10	ER50R10	ER80R10
4	ROLLER WHEEL ASSEMBLY	7	ER32RCA	ER50RCA	ER80RCA
6	BEARING RETAINER	4	ET32R04	ET32R04	ET80R04
7	BEARING RETAINER SCREWS	4	CFT-CM3X0.5-008	CFT-CM3X0.5-008	CF-CM6X1.0-016
8	ROLLER PLATE BOLTS	16	CS-CM3X0.5-006	CS-CM4X0.7-008	CS-CM5X0.8-016-Z
9	ECCENTRICS	3	ER32R12	ER32R12	ER80R04
10	TOP ROLLER SCREWS	3	CB-CM4X0.7-012	CS-CM4X0.7-016	CS-CM6X1.0-020
11	SWITCH MAGNETS	2	ER32M10	ER80M10	ER80M10
16	U.H.M.W. COVER SLIDE	1	ER32R14BSC	ER50R14BSC	ER80R14BSC
17A	TOP LOAD PLATE (BELTED)	1	ER32R05-SB	ER50R05-SB	ER80R05-SB
18	TOP LOAD PLATE SCREWS	8	CS-CM3X0.5-010-Z	CS-CM4X0.7-012-Z	CS-CM5X0.8-016-Z
19	STRIP GUIDES	2	ER32R06	ER50R06	ER80R06
20	STRIP GUIDES SCREWS	4	CS-CM3X0.5-008-Z	CS-CM4X0.7-008-Z	CS-CM4X0.7-010-Z
21	SERRATED WASHER	16	B2124	B2125	B2115
25	BELT CLAMP ADJ. SCREWS	2	CS-CM4X0.7-016	CS-CM4X0.7-016	CS-CM5X0.8-018
26	BELT CLAMP	2	ER32R09	ER50R09	ER80R09
27	BELT DRIVE END CAPS	2	ER32E03	ER50E03	ER80E03
34	STRIP GUIDE CLAMP	2	ER32M05	ER50M05	ER80M05
35	STRIP GUIDE CLAMP SCREWS	4	CB-CM4X0.7-008-Z	CB-CM4X0.7-008-Z	CB-CM4X0.7-008-Z
39B	TIE ROD BOLTS	4	M6-M5-C	M8-M6-C	M10-M8-C
40	TIE ROD NUTS	8	32-27015	50-27015	80-27015
42	BUMPER PLATE MOUNTING SCREWS	4	CS-CM3X0.5-012	CS-CM3X0.5-010	CS-CM5X0.8-010
43	BELT DRIVE BUMPER	2	B8504-32ER	B8504-50ER	B8504-80ER
44	BELT DRIVE BUMPER PLATE	2	ER32M12	ER50M12	ER80M12
45	BELT DRIVE PULLEY	2	ER32P01	ER50P01	ER80P01
46A	BELT DRIVE IN LINE SHAFT	1	ER32S02	ER50S02	ER80S02
46B	BELT DRIVE PARALLEL SHAFT	1	ER32S03	ER50S03	ER80S03
46C	BELT DRIVE PARALLEL SHAFT W/ BK	1	N/A	ER50S04	ER80S04
46D	BELT DRIVE PARALLEL W/ LINK & BK	1	N/A	ER50S09	ER80S09
47	BELT DRIVE BEARINGS	4	RA382	RA374	RA375
48	BELT DRIVE SHAFT SPACER	2	ER32S05	ER50S05	ER80S05
49	BELT DRIVE END CAP COVERS	3	ER32M07	ER50M07	ER80M07
50	BELT DRIVE E.C. COVERS SCREW	12	CB-CM3X0.5-008-Z	ESF4005-12	ESF4006-08
51	BELT DRIVE IDLER SHAFT	1	ER32S01	ER50S01	ER80S01
52	BELT DRIVE END MOUNTING CAPS	2	ET32E07	ET50E07	ET80E07
53	BELT DRIVE BUMPER SCREWS	2	CS-CM5X0.8-012	CS-CM5X0.8-020	CS-CM6X1.0-010
54	BELT DRIVE IDLER SHAFT KEY S	2	B8534M2-14	B8534M3-20	B8534M5-25
55A	BELT DRIVE IN LINE SHAFT KEY	1	B8534M2-06	B8534M2-08	B8534M5-14
55B	BELT DRIVE PARALLEL KEY.	1	B8534M2-20	B8534M2-20	B8534M5-32
56	BELT DRIVE BELT	1	ER32B01BSC	ER50B01BSC	ER80B01BSC
59	STRIP SEAL	1	ER32M06BSC	ER50M06BSC	ER80M06BSC
60	STRIP SEAL MAGNETS	2	ER32M11BSC	ER32M11BSC	ER32M11BSC
61	BODY	1	ER32CXXXX	ER50CXXXX	ER80CXXXX

ER Series Inline Motor Mounting

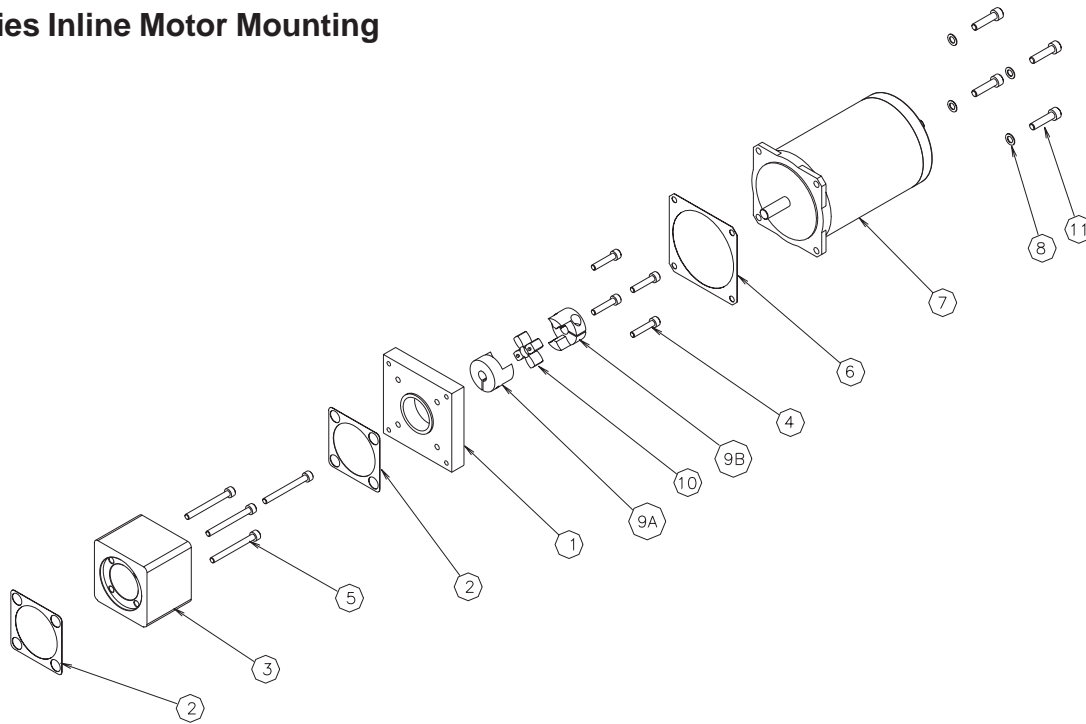

ER32

Part No.	Description	Step Motors	Servo Motors	DC Brush Motors
		S57-102	SM233B	AD23A
1	MOTOR ADAPTOR FLANGE	ET32E05	ET32E09	ET32E05
2	GASKET	ET32M05	ET32M05	ET32M05
3	COUPLER HOUSING	ET32E04	ET32E04	ET32E04
4	FLANGE MOUNTING BOLTS	CFT-CM3X0.5-012	CS-CM3X0.5-025	CFT-CM3X0.5-012
5	COUPLER HOUSING SCREWS	CS-CM3X0.5-035	CS-CM3X0.5-035	CS-CM3X0.5-035
6	GASKET	ET50M06	ET50M06	ET50M06
7	MOTOR	S57-102MO	SM233B (2 VERSIONS)	AD23A-048-10
8	WASHER	WS-SLR-CM05-Z	WS-SLR-CM05-Z	WS-SLR-CM05-Z
9A	SCREW COUPLER	GCM100602	RGSM090602	GCM100602
9B	MOTOR COUPLER	GC102500	RGS093813	GC102500
10	COUPLER INSERT	GC12-SU	RGS0998	GC12-SU
11	MOTOR MOUNTING SCREWS	CS-CM5X0.8-012-Z	CS-CM5X0.8-018-Z	CS-CM5X0.8-012-Z

ER50

Part No.	Description	Step Motors		Servo Motors	
		S57-102	S83-135	SM233B	J092
1	MOTOR ADAPTOR FLANGE	N/A	ET50E05	N/A	ET50E11
2	GASKET	ET50M05	ET50M05	ET50M05	ET50M05
3	COUPLER HOUSING	ET50E04	ET50E04	ET50E15	ET50E04
4	FLANGE MOUNTING BOLTS	N/A	CS-CM5X0.8-016	N/A	CF-CM5X0.8-016
5	COUPLER HOUSING SCREWS	CS-CM5X0.8-050	CS-CM5X0.8-050	CS-CM5X0.8-050	CS-CM5X0.8-050
6	GASKET	ET50M06	ET50M13	ET50M06	ET50M11
7	MOTOR	S57-102MO	S83-135MO	SM233B (2 VERSIONS)	J092 (3 VERSIONS)
8	WASHER	WS-SLR-CM05-Z	WS-SLR-CM05-Z	WS-SLR-CM05-Z	WS-SLR-CM06-Z
9A	SCREW COUPLER	GCM18082	GCM18082	RGSM140802	RGSM140802
9B	MOTOR COUPLER	GC182500	GC183800	RGS143813	RGS141405
10	COUPLER INSERT	GC19-SU	GC19-SU	RGS1498	RGS1498
11	MOTOR MOUNTING SCREWS	CS-CM5X0.8-016-Z	CS-CM5X0.8-016-Z	CS-CM5X0.8-018-Z	CS-CM6X1.0-025-Z

Exploded View- Inline Motor Mounting**ER Series Rodless Actuator****ER50**

Part No.	Description	DC Brush Motors	
		AD23A	AD34A
1	MOTOR ADAPTOR FLANGE	N/A	ET50E05
2	GASKET	ET50M05	ET50M05
3	COUPLER HOUSING	ET50E04	ET50E04
4	FLANGE MOUNTING BOLTS	N/A	CS-CM5X0.8-016
5	COUPLER HOUSING SCREWS	CS-CM5X0.8-050	CS-CM5X0.8-050
6	GASKET	ET50M06	ET50M13
7	MOTOR	AD23A-048-10	AD34A-048-10
8	WASHER	WS-SLR-CM05-Z	WS-SLR-CM05-Z
9A	SCREW COUPLER	GCM18082	GCM18082
9B	MOTOR COUPLER	GC182500	GC183800
10	COUPLER INSERT	GC19-SU	GC19-SU
11	MOTOR MOUNTING SCREWS	CS-CM5X0.8-016-Z	CS-CM5X0.8-016-Z

ER80

Part No.	Description	Step Motors		Servo Motors	
		S83-135	S106-178	J092	APEX620
1	MOTOR ADAPTOR FLANGE	N/A	ET80E05	N/A	ET80E11
2	GASKET	ET80M05	ET80M05	ET80M05	ET80M05
3	COUPLER HOUSING	ET80E04	ET80E04	ET80E14	ET80E04
4	FLANGE MOUNTING BOLTS	N/A	CF-CM5x0.8-020	N/A	CF-CM5X0.8-030
5	COUPLER HOUSING SCREWS	CS-CM6x1.0-080	CS-CM6x1.0-080	CS-CM6x1.0-080	CS-CM6x1.0-080
6	GASKET	ET80M13	ET80M12	ET50M11	ET100M12
7	MOTOR	S83-135	S106-178	J092 (3 VERSIONS)	APEX620
8	WASHER	WS-SLR-CM05-Z	WS-SLR-CM06-Z	WS-SLR-CM06-Z	ESF1108
9A	SCREW COUPLER	GCM401405	GCM401405	RGSM191405	RGSM191405
9B	MOTOR COUPLER	GC403800	GC406313	RGS	RGSM192408
10	COUPLER INSERT	GC42-SU	GC42-SU	RGS1998	RGS1998
11	MOTOR MOUNTING SCREWS	CS-CM5X0.8-016-Z	ESF4106-20	CS-CM6X1.0-025-Z	CS-CM8X1.25-035-Z

ER80

Part No.	Description	DC Brush Motors	
		AD34A	AD42A
1	MOTOR ADAPTOR FLANGE	N/A	ET80E05
2	GASKET	ET80M05	ET80M05
3	COUPLER HOUSING	ET80E04	ET80E04
4	FLANGE MOUNTING BOLTS	N/A	CF-CM5x0.8-020
5	COUPLER HOUSING SCREWS	CS-CM6x1.0-080	CS-CM6x1.0-080
6	GASKET	ET80M13	ET80M12
7	MOTOR	AD34A-048-10	AD42A-090-10
8	WASHER	WS-SLR-CM05-Z	WS-SLR-CM06-Z
9A	SCREW COUPLER	GCM401405	GCM401405
9B	MOTOR COUPLER	GC403800	GC406313
10	COUPLER INSERT	GC42-SU	GC42-SU
11	MOTOR MOUNTING SCREWS	CS-CM5X0.8-016-Z	ESF4106-20

Exploded View- Parallel Motor Mounting

ER Series Rodless Actuator

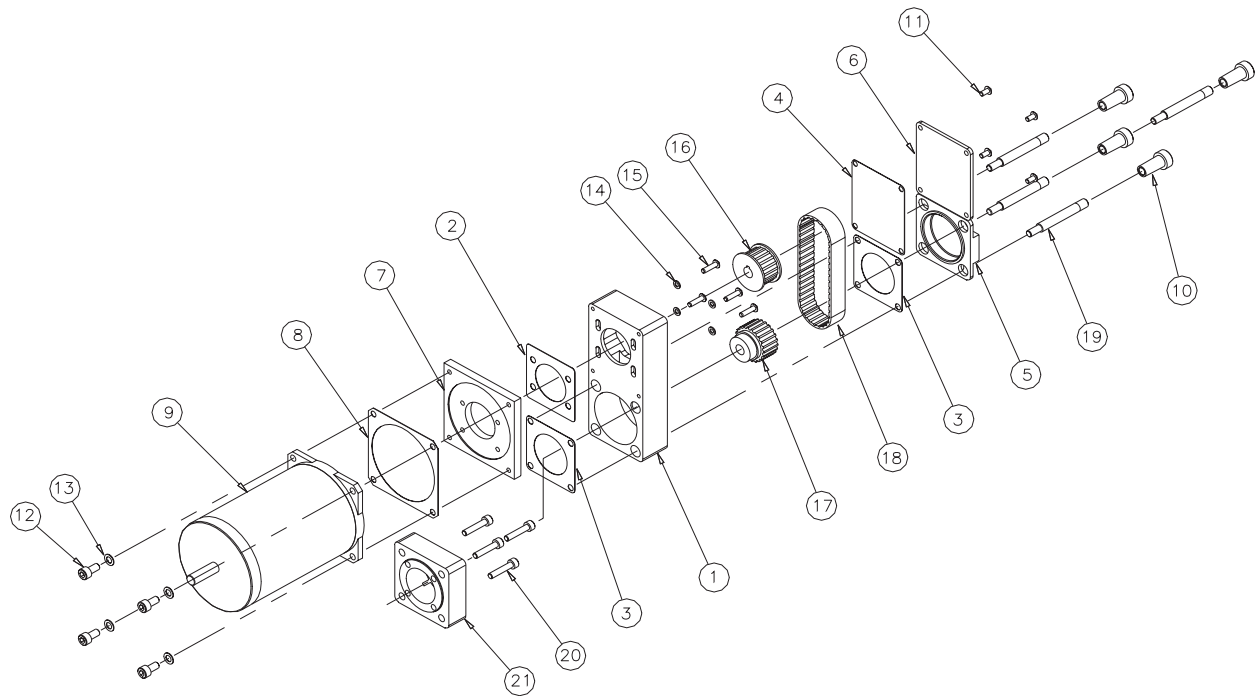

ER32

Part No.	Description	Step Motors	Servo Motors	DC Brush Motors
		S57-102	SM233B	AD23A
1	PARALLEL MOUNT HOUSING	ET32E06	ET32E06	ET32E06
2	GASKET	ET32M09	ET32M09	ET32M09
3	GASKET	ET32M05	ET32M05	ET32M05
4	GASKET	ET32M08	ET32M08	ET32M08
5	END CAP	ET32E07	ET32E07	ET32E07
6	PARALLEL MOUNT COVER	ET32E10	ET32E10	ET32E10
7	MOTOR ADAPTOR FLANGE	ET32E08	ET32E08	ET32E08
8	GASKET	ET50M06	ET50M06	ET50M06
9	MOTOR	S57-102	SM233B (2 VERSIONS)	AD23A-048-10
10	TIE ROD NUT	32-27015	32-27015	32-27015
11	COVER SCREWS	CB-CM3X0.5-008-Z	CB-CM3X0.5-008-Z	CB-CM3X0.5-008-Z
12	MOTOR MOUNTING SCREWS	CS-CM5X0.8-012-Z	CS-CM5X0.8-014-Z	CS-CM5X0.8-012-Z
13	WASHER	WS-SLR-CM05-Z	WS-SLR-CM05-Z	WS-SLR-CM05-Z
14	WASHER	B2128-M4	B2128-M4	B2128-M4
15	ADAPTOR SCREWS	CB-CM4X0.7-010	CB-CM4X0.7-010	CB-CM4X0.7-010
16-18	SEE PULLEY - BELT TABLES			
19	PARALLEL MOUNT STUD	B8805-M6-50	B8805-M6-50	B8805-M6-50
20	ADPATOR SCREWS*	CS-CM3X0.5-020	CS-CM3X0.5-020	CS-CM3X0.5-020
21	ER BELT DRIVE ADAPTOR*	ER32M09	ER32M09	ER32M09

* ER BELT DRIVE ONLY

Exploded View- Parallel Motor Mounting

ER50

Part No.	Description	Step Motors		Servo Motors	
		S57-102	S83-135	SM233B	J092
1	PARALLEL MOUNT HOUSING	ET50E06	ET50E06	ET50E06	ET50E06
2	GASKET	ET50M09	ET50M09	ET50M09	ET50M09
3	GASKET	ET50M05	ET50M05	ET50M05	ET50M05
4	GASKET	ET50M08	ET50M08	ET50M08	ET50M08
5	END CAP	ET50E07	ET50E07	ET50E07	ET50E07
6	PARALLEL MOUNT COVER	ET50E10	ET50E10	ET50E10	ET50E10
7	MOTOR ADAPTOR FLANGE	ET50E08	ET50E09	ET50E08	ET50E17
8	GASKET	ET50M06	ET50M06	ET50M06	ET50M06
9	MOTOR	S57-102	S83-135	SM233B (2 VERSIONS)	J092 (3 VERSIONS)
10	TIE ROD NUT	50-27015	50-27015	50-27015	50-27015
11	COVER SCREWS	CB-CM4X0.7-012-Z	CB-CM4X0.7-012-Z	CB-CM4X0.7-012-Z	CB-CM4X0.7-012-Z
12	MOTOR MOUNTING SCREWS	CS-CM5X0.8-012-Z	CS-CM5X0.8-012-Z	CS-CM5X0.8-014-Z	CS-CM6X1.0-025-Z
13	WASHER	WS-SLR-CM05-Z	WS-SLR-CM05-Z	WS-SLR-CM05-Z	WS-SLR-CM06-Z
14	WASHER	B2128-M5	B2128-M5	B2128-M5	B2128-M5
15	ADAPTOR SCREWS	CB-CM5X0.8-010	CB-CM5X0.8-010	CB-CM5X0.8-010	CB-CM5X0.8-010
16-18	SEE PULLEY-BELT TABLES				
19	PARALLEL MOUNT STUD	B8805-M8-60	B8805-M8-60	B8805-M8-60	B8805-M8-60
20	ADAPTOR SCREWS*	CS-CM5X0.8-025	CS-CM5X0.8-025	CS-CM5X0.8-025	CS-CM5X0.8-025
21	ER BELT DRIVE ADAPTOR*	ER50M09	ER50M09	ER50M09	ER50M09

* ER BELT DRIVE ONLY

Part No.	Description	DC Brush Motors	
		AD23A	AD34A
1	PARALLEL MOUNT HOUSING	ET50E06	ET50E06
2	GASKET	ET50M09	ET50M09
3	GASKET	ET50M05	ET50M05
4	GASKET	ET50M08	ET50M08
5	END CAP	ET50E07	ET50E07
6	PARALLEL MOUNT COVER	ET50E10	ET50E10
7	MOTOR ADAPTOR FLANGE	ET50E08	ET50E09
8	GASKET	ET50M06	ET50M06
9	MOTOR	AD23A-048-10	AD34A-048-10
10	TIE ROD NUT	50-27015	50-27015
11	COVER SCREWS	CB-CM4X0.7-012-Z	CB-CM4X0.7-012-Z
12	MOTOR MOUNTING SCREWS	CS-CM5X0.8-012-Z	CS-CM5X0.8-012-Z
13	WASHER	WS-SLR-CM05-Z	WS-SLR-CM05-Z
14	WASHER	B2128-M5	B2128-M5
15	ADAPTOR SCREWS	CB-CM5X0.8-010	CB-CM5X0.8-010
16-18	SEE PULLEY-BELT TABLES		
19	PARALLEL MOUNT STUD	B8805-M8-60	B8805-M8-60
20	ADAPTOR SCREWS*	CS-CM5X0.8-025	CS-CM5X0.8-025
21	ER BELT DRIVE ADAPTOR*	ER50M09	ER50M09

* ER BELT DRIVE ONLY

Exploded View- Parallel Motor Mounting**ER Series Rodless Actuator****ER80**

Part No.	Description	Step Motors		Servo Motor
		S83-135	S106-178	J092
1	PARALLEL MOUNT HOUSING	ET80E06	ET80E06	ET80E06
2	GASKET	ET80M09	ET80M09	ET80M09
3	GASKET	ET80M05	ET80M05	ET80M05
4	GASKET	ET80M08	ET80M08	ET80M08
5	END CAP	ET80E07	ET80E07	ET80E07
6	PARALLEL MOUNT COVER	ET80E10	ET80E10	ET80E10
7	MOTOR ADAPTOR FLANGE	ET80E08	ET80E09	ET80E16
8	GASKET	ET80M13	ET80M12	ET50M11
9	MOTOR	S83-135	S106-178	J092 (3 VERSIONS)
10	TIE ROD NUT	80-27015	80-27015	80-27015
11	COVER SCREWS	ESF4005-12	ESF4005-12	ESF4005-12
12	MOTOR MOUNTING SCREWS	CS-CM5X0.8-012-Z	CS-CM6X1.0-016-Z	ESF4106-20
13	WASHER	WS-SLR-CM05-Z	WS-SLR-CM06-Z	WS-SLR-CM06-Z
14	WASHER	B2128-M6	B2128-M6	B2128-M6
15	ADAPTOR SCREWS	CB-CM6X1.0-012	CB-CM6X1.0-012	CB-CM6X1.0-012
16-18	SEE PULLEY -BELT TABLES			
19	PARALLEL MOUNT STUD	B8805-M10-90	B8805-M10-90	B8805-M10-90
20	ADAPTOR SCREWS*	CS-CM6X1.0-035	CS-CM6X1.0-035	CS-CM6X1.0-035
21	ER BELT DRIVE ADAPTOR*	ER80M09	ER80M09	ER80M09

* ER BELT DRIVE ONLY

Part No.	Description	DC Brush Motors	
		AD34A	AD42A
1	PARALLEL MOUNT HOUSING	ET80E06	ET80E06
2	GASKET	ET80M09	ET80M09
3	GASKET	ET80M05	ET80M05
4	GASKET	ET80M08	ET80M08
5	END CAP	ET80E07	ET80E07
6	PARALLEL MOUNT COVER	ET80E10	ET80E10
7	MOTOR ADAPTOR FLANGE	ET80E08	ET80E09
8	GASKET	ET80M13	ET80M12
9	MOTOR	AD34A-048-10	AD42A-090-10
10	TIE ROD NUT	80-27015	80-27015
11	COVER SCREWS	ESF4005-12	ESF4005-12
12	MOTOR MOUNTING SCREWS	CS-CM5X0.8-012-Z	CS-CM6X1.0-016-Z
13	WASHER	WS-SLR-CM05-Z	WS-SLR-CM06-Z
14	WASHER	B2128-M6	B2128-M6
15	ADAPTOR SCREWS	CB-CM6X1.0-012	CB-CM6X1.0-012
16-18	SEE PULLEY -BELT TABLES		
19	PARALLEL MOUNT STUD	B8805-M10-90	B8805-M10-90
20	ADAPTOR SCREWS*	CS-CM6X1.0-035	CS-CM6X1.0-035
21	ER BELT DRIVE ADAPTOR*	ER80M09	ER80M09

* ER BELT DRIVE ONLY

Exploded View- Parallel Motor Mounting

ER Series Rodless Actuator

ER Series Belt-Pulley Tables

ER32

			Step Motors		Servo Motors		DC Brush Motors	
			S57-102		SM233B w/ T shaft option		AD23A	
Part No.	Description	Ratio >	1:1	1:1.5	1:1	1:1.5	1:1	1:1.5
16	MOTOR PULLEY		B8793F-20	B8793F-24	B8793-2038	B8793-2438	B8793F-20	B8793F-24
17	DRIVEN PULLEY		B8789-20	B8789-16	B8789-20	B8789-16	B8789-20	B8789-16
18	TIMING BELT		B8801-15-56	B8801-15-56	B8801-15-56	B8801-15-56	B8801-15-56	B8801-15-56

ER50

			Step Motors				
			S57-102			S83-135	
Part No.	Description	Ratio >	1:1	1.5:1	2:1	1:1	1.5:1
16	MOTOR PULLEY		B8793F-28	B8793F-22	B8793F-18	B8794F-18	B8794F-14
17	DRIVEN PULLEY		B8790-28	B8790-33	B8790-36	B8791-18	B8791-21
18	TIMING BELT		B8801-15-78	B8801-15-78	B8801-15-78	B8802-15-51	B8802-15-51

			Servo motors		
			SM233B w/ T shaft option		J092
Part No.	Description	Ratio >	1:1	1.5:1	1:1
16	MOTOR PULLEY		B8793-2838	B8793-2238	B8794-1855
17	DRIVEN PULLEY		B8790-28	B8790-33	B8791-18
18	TIMING BELT		B8801-15-78	B8801-15-78	B8802-15-51

			DC Brush Motors				
			AD23A			AD34A	
Part No.	Description	Ratio >	1:1	1.5:1	2:1	1:1	1.5:1
16	MOTOR PULLEY		B8793F-28	B8793F-22	B8793F-18	B8794F-18	B8794F-14
17	DRIVEN PULLEY		B8790-28	B8790-33	B8790-36	B8791-18	B8791-21
18	TIMING BELT		B8801-15-78	B8801-15-78	B8801-15-78	B8802-15-51	B8802-15-51

ER80

			Step Motors				
			S83-135			S106-178	
Part No.	Description	Ratio >	1:1	1.5:1	2:1	1:1	1.5:1
16	MOTOR PULLEY		B8794F-28	B8794F-22	B8794F-18	B8795F-28	B8794F-22
17	DRIVEN PULLEY		B8792-28	B8792-33	B8792-36	B8792-28	B8791-33
18	TIMING BELT		B8802-15-66	B8802-25-66	B8802-25-66	B8802-25-70	B8802-25-70

			Servo motors	
			J092	
Part No.	Description	Ratio >	1:1	1.5:1
16	MOTOR PULLEY		B8795-2855	B8795-2255
17	DRIVEN PULLEY		B8792-28	B8792-33
18	TIMING BELT		B8802-25-66	B8801-15-78

			DC Brush Motors				
			AD34A			AD42A	
Part No.	Description	Ratio >	1:1	1.5:1	2:1	1:1	1.5:1
16	MOTOR PULLEY		B8794F-28	B8794F-22	B8794F-18	B8795F-28	B8794F-22
17	DRIVEN PULLEY		B8792-28	B8792-33	B8792-36	B8792-28	B8791-33
18	TIMING BELT		B8802-15-66	B8802-25-66	B8802-25-66	B8802-25-70	B8802-25-70

ER Series Maintenance**ER Series Maintenance****Contents:**

Cleaning	22
Lubrication	22
Timing Belt Tension Adjustment	23
Coupler and Pulley Spacing	24
Torque Specifications	25
Assembly Information (Adhesives and Lubricants)	25
Roller Bearing Carriage Preloading	26
Belt Drive Tensioning	30

Cleaning

Actuator external surfaces may be cleaned with a clean, dry cloth. Use only mild, non-corrosive cleaning agent. Keep strip seal clear of debris. Inspect area around carriage for signs of contamination. Keep the strip seal free of debris. Environments with high concentrations of small particles, such as metal shavings, dust, and sawdust may require the ER unit to be fitted with a positive pressurization tube and fitting. Call the factory for details at (330) 336-3511.

Do not use high pressure washdown or steam-lance cleaning systems.

Lubrication

ER Series actuators are lubricated upon assembly. In most cases, this lubrication will suffice for the life of the actuator. Applications that require high speeds, high duty cycles or strokes that do not allow ball nut ball bearings to completely recirculate may require additional lubrication. The angular contact thrust bearings are lubricated for life, as are the roller bearing wheels. Square rail bearings supplied with ER Series actuators typically require no additional lubrication.

To inspect the ball screw or acme lead screw to determine if lubrication is necessary, remove the strip clamps from either end cap and lift the strip seal. Be careful not to pull on the seal. With the drive screw exposed, verify that an adequate amount of lubrication is present on the screw threads. Should additional lubrication be required, Parker AAD recommends the following:

- MagnaLube (p/n 1331815-000-01), 1.5 oz tube (grease)
- Thomson Linear Lube, 14.5 oz tube (grease)

Depending on the conditions of use, it may be necessary to establish a lubrication schedule for your actuator. Please contact the factory at (330) 336-3511 for additional information.

Timing Belt Adjustment

Adjusting Timing Belt Tension for Parallel Mount Motors

In order to ensure long belt life and consistent performance, it is important to tension the timing belt correctly. Too little tension may lead to belt tooth skipping, while too much tension adds tension to the belt and causes side loading on both the motor and screw shafts.

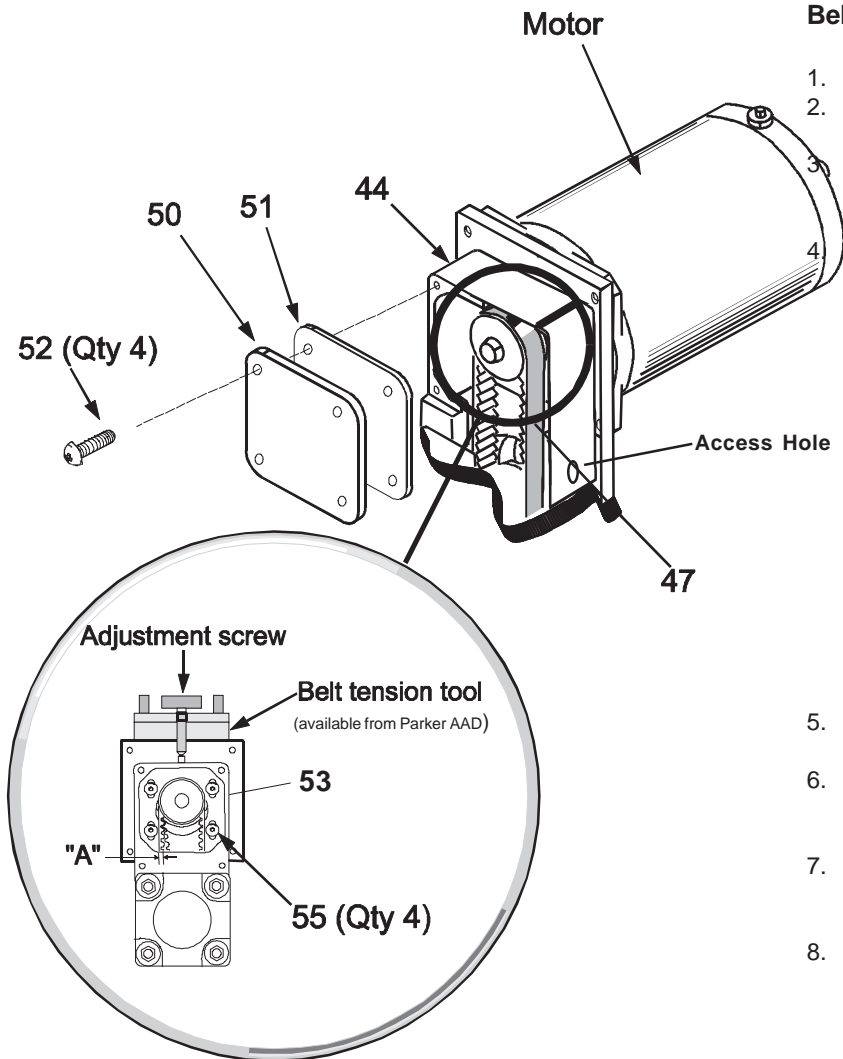

Belt Tensioning Procedure

1. Remove four button head cap screws (52).
2. Remove cover (50) and gasket (51) from end cap (44).
3. Loosen four button head cap screws (55). Loosen just enough to allow motor to move freely.
4. Adjust belt (47) tension. Refer to Belt tension table for deflection values. A belt with correct tension should deflect the listed value (table below) with the force applied at the access hole in the housing (44) using Gates Tension Tester (P/N 7401-0076).
 - Using belt tension tool
 - Attach belt tension tool assembly to mounting plate (53). Turn adjustment screw as required to properly tension the timing belt. (Tensioning procedure supplied with tool.)
 - By hand
 - a. Maintaining proper tension force on the belt at the middle of the belt span (see chart), tighten button head cap screws (55).
 - b. Check for proper belt deflection.
5. Visually inspect for proper seating of belt teeth in pulley grooves.
6. Torque the four button head cap screws (55). (Refer to the torque values chart located on page XX.)
7. Place gasket (51) and cover (50) on end cap (44), securing with four button head cap screws (52).
8. Torque the four button head cap screws (52) as required. (Refer to the torque values chart located earlier in this section.)

Profile Size	Dimension "A" Deflection Value*	Force
32	3 mm (0.12 in)	17 N (3.7 lb)
50	3 mm (0.12 in)	25 N (5.5 lb)
80	3 mm (0.12 in)	10 N (2.2 lb)

* At mid-span of belt via access hole.

Coupler and Pulley Spacing

Motor Coupler and Pulley spacing

Motor coupler and pulley spacing refers to the required position of the coupler or pulley on the motor shaft to ensure correct coupler or belt engagement.

1. Determine type of motor (inline or parallel).
2. Referring to the appropriate illustration and specification table, assemble coupler to motor shaft using Loctite 609. Make sure to measure the “A” dimension from the mounting face of the motor. Do not measure off of the pilot. Tighten set screw (if applicable).
3. Make sure to torque motor mounting hardware as necessary (if applicable). Refer to page 14 for torque values.

NOTE: Use precautions contained with Loctite or any other adhesive used in assembly.

Pulley Spacing for Parallel Driven Units

Parallel Motors dimension “A”			
Motor	ER32	ER50	ER80
S57-102, AD23A	0.176	0.193	—
S83-135, AD34A	—	0.190	0.255
S106-178, AD42A	—	—	0.193
SM16x	0.364	—	—
SM233*	0.176	0.193	—
J034x	—	0.190	0.193
J092x	—	0.410	0.311
APEX605,6	—	—	0.311
APEX610	—	—	0.311

* T- shaft option

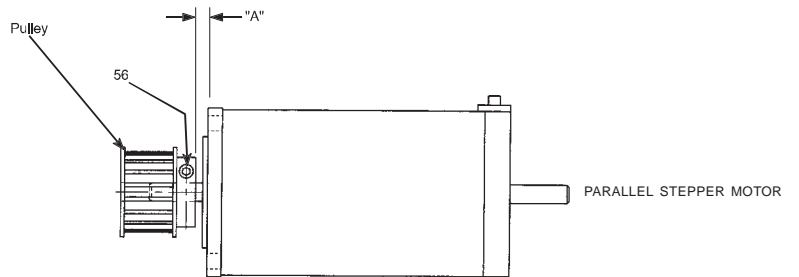

Coupler Spacing for Inline Driven Units

Inline Stepper and DC Motors dimension “A”		
Model	Motor (Step, DC)	Dimension
ERS32	S57-102, AD23A	0.331
ERS50	S57-102, AD23A	0.102
ERS50	S83-135, AD34A	0.693
ERS80	S83-135, AD34A	0.134
ERS80	S106-178, AD42A	0.528

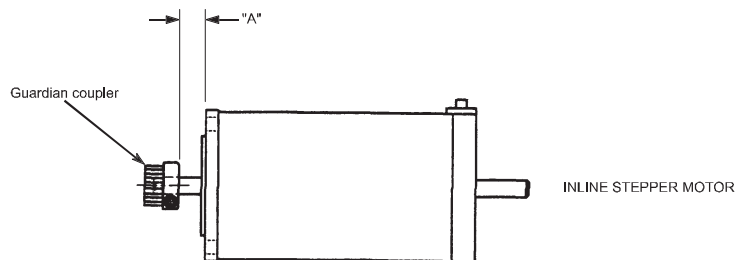

Inline Servo Motors dimension “A”		
Model	Motor	Dimension
ERB32	SM16	0.984
ERB32	SM233B*	0.450
ERB50	SM233B*	0.773
ERB50	J034x	0.852
ERB50	J092x, APEX605 & 606	0.749
ERB80	J034x	0.356
ERB80	J092x	0.218
ERB80	APEX605, 606, & 610	0.218
ERB80	APEX620	0.995

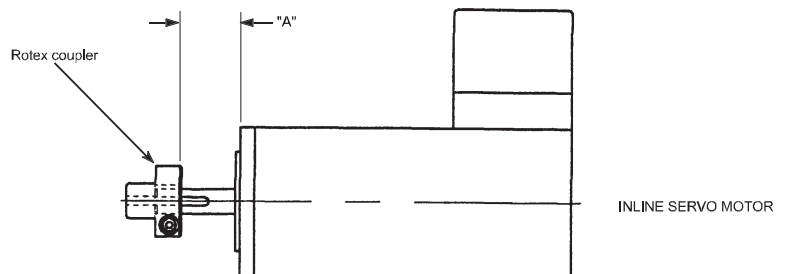

* T- shaft option



Assembly Requirements

Fastener Adhesives

The following parts, when assembled, require the use of industrial lubricants or adhesives as indicated.

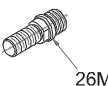
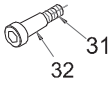
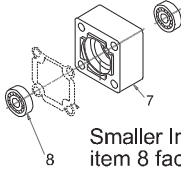
Part	Description	Lubricant/Adhesive
	Cylinder rod-end - Female	Loctite 271
	Flat Head Cap Screw	Loctite 242
	Set screw	Loctite 242
	Cylinder rod-end - Male	Loctite 271
	Tie rod bolt and tie rod nut <i>Apply between the tie rod bolt and nut only.</i>	Loctite 271
	Screw support bearing <i>If not sealed</i> Smaller Inner Race of item 8 faces End Cap (7).	Grease

Fastener Torque Table

Description	Part Numbers		ER32			ER50			ER80		
	Screw	Belt	Size	in-lb	Nm	Size	in-lb	Nm	Size	in-lb	Nm
Roller Plate SHCS	8	8	M3	19	2.1	M4	41	4.6	M5	84	9.5
Roller Retainer FHCS (SH)	7 (10)	7 (10)	M3(M4)	11(25)	1.2(2.8)	M3(M4)	11(41)	1.2(4.6)	M6(M6)	84(84)	9.5(9.5)
Square Rail Bearing SHCS	23	n/a	M3	11	1.2	M3	11	1.2	M5	84	9.5
Bearing Locknut SHCS	37A	n/a	M3	11	1.2	M3	11	1.2	M4	50	4
Actuator Tie Bolts	38,40	38/40	M5,M6	85	9.6	M6,M8	210	23.7	M8,M10	415	46.9
Coupler SHCS (Servo)	1	1	M2,M5	11	1.2	M3	11	1.2	M4	41	4.6
Coupler SHCS (Step/DC)	1	1	3/32	11	1.2	7/64	11	1.2	5/32	41	4.6
Motor Adaptor SH/FHCS	4	4	M3	11	1.2	M5	50	5.7	M6	50	5.7
Motor Mounting Bolts	11,12 ²	11,12 ²	M5	50	5.7	M5,M6	50,85	5.7,9.6	M5,M6	50,85	5.7,9.6
Parallel Flange BHCS	15	15	M4	41	4.6	M5	50	5.7	M6	85	9.6
Parallel Cover BHCS	11	11	M3	11	1.2	M4	41	4.6	M5	50	5.7
Drive Pulley SHCS	1	1	M2,M5	11	1.2	M2,5	11	1.2	M3,M4	11,41	1.2,4.6
Load Attachment SHCS	18	18	M3	11	1.2	M4	25	2.8	M5	84	9.5
Strip Clamp BHCS	35	35	M4	25	2.8	M4	25	2.8	M4	25	2.8
Strip Guide SHCS	20	20	M3	11	1.2	M4	25	2.8	M4	25	2.8
Nut Retainer FHCS	13	13	M4	25	2.8	M4	25	2.8	M6	84	9.5

¹ Not pictured; coupler parts are 9A and 9B ² 11 for inline, 12 for parallel mounting

Bearing Carriage Adjustment

ER Series Roller Bearing Carriages

The ER Series roller bearing carriage is preloaded against normal and side loading, and pitch, yaw and roll moment loading (as shown at right). Each of the seven roller bearing wheels consist of a quality radial bearing and Nylon cover. This Nylon material is designed for long life and minimal distortion under load.

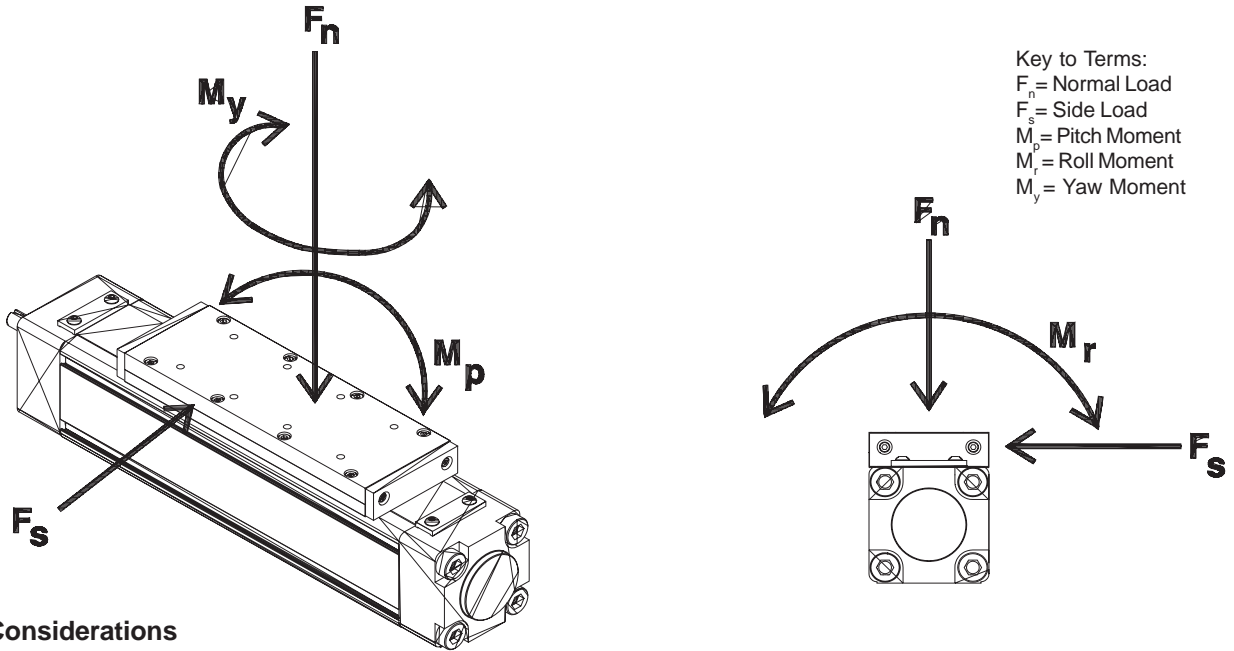

Load Considerations

It is important to consider the parameters of the application to best select an actuator. Should the actuator experience difficulties during use, it may be necessary to consider the application when searching for a cause.

Two factors limit the performance of the roller bearing carriage, speed and temperature. Under conditions of excessive speed or temperature, the load capacity of the carriage should be derated as shown in the graphs to the right.

To calculate the effective load, divide the actual load by the temperature and speed factors as shown in the formula below.

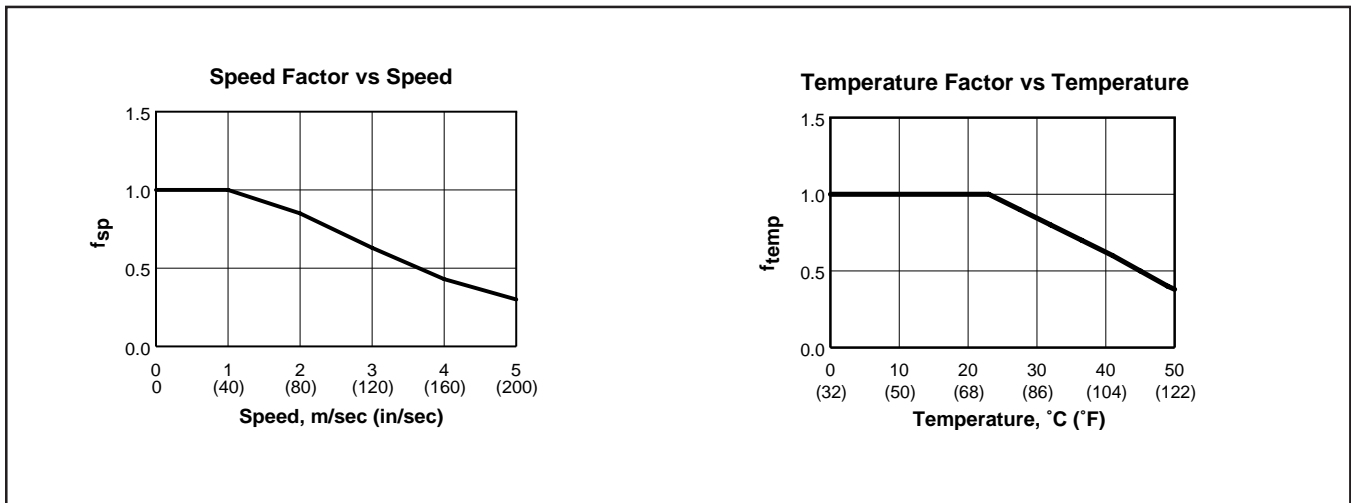

Calculate Effective Load (L_{eff}):

$$L_{eff} = L_{act} / (f_{sp} \times f_{temp})$$

Roller Bearing Carriage Preloading**When would it be necessary to preload the carriage?**

Under normal operating conditions (as specified in Parker Catalog 1894), the carriage should not lose preload. A loss of preload can result in noticeable play in the carriage in any direction. Should the carriage feel "loose" in the actuator body, follow the following procedure to reset the carriage preload.

Screw Drive Actuators

1. Disassemble the actuator.
 - a Detach the load from the actuator.
 - b Remove the load attachment plate (8 socket head cap screws).
 - c Loosen the screws on the strip seal clamps and carefully remove the strip seal.
CAUTION: Strip seal edges are sharp!
 - d Detach the motor mounting assembly. For parallel driven units, it may be necessary to loosen the timing belt before removing the four mounting bolts that attach the entire assembly. For inline driven units, remove the motor and coupler housing (four screws for each part).
 - e Remove the bolts that attach the motor-side end cap (containing the thrust bearings) to the actuator body.
 - f Remove the mounting bolts from the non-driven end cap.
The carriage-screw assembly should now be axially somewhat loose in the actuator body.
 - g Separate the non-driven end cap from the actuator body. To do this, rotate the drive screw until the carriage lightly meets the end of travel at the non-driven end cap. Once there, slowly rotate the drive screw; it will act as a jacking screw to separate the end cap from the body. The screw and bearing are held together with an adhesive, and it may require some effort to carefully separate them.
 - h Remove the carriage and screw assembly from the actuator body, but do not remove the carriage from the screw!
 - i Proceed to **Preloading Procedure**.

Figure 1: Actuator Components

Top: Screw Drive
Bottom: Belt Drive

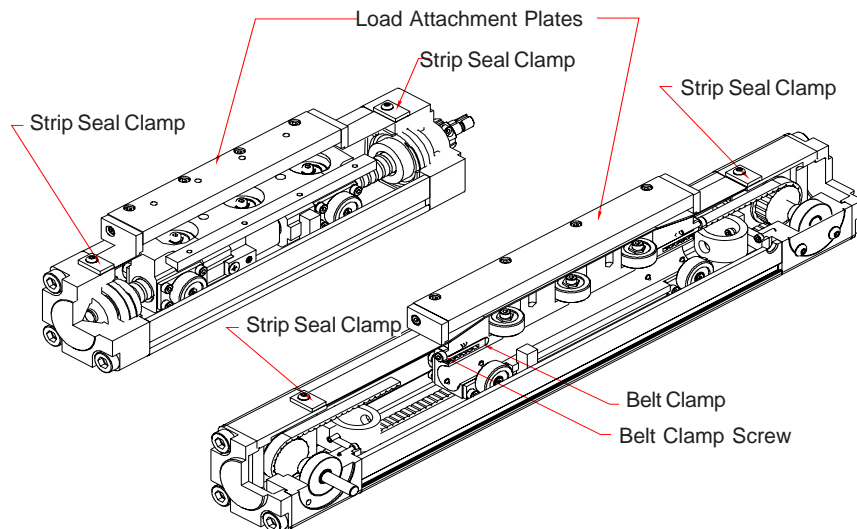
**Belt-Drive Actuators**

1. Disassemble the actuator.
 - a Detach the load from the actuator.
 - b Remove the load attachment plate (8 socket head cap screws).
 - c Loosen the screws on the strip seal clamps and carefully remove the strip seal.
CAUTION: Strip seal edges are sharp!
 - d Detach the belt clamps from both sides of the carriage by removing the single socket head cap screws from the carriage.
 - e Remove the bolts that attach the non-driven end cap to the actuator body and remove the end cap.
 - f Remove the carriage from the actuator body.
 - g Proceed to **Preloading Procedure**.

Roller Bearing Carriage Preloading**Roller Bearing Carriage Preloading Procedure**

1. **Inspect the carriage** for excess grease or contamination. Wipe off excess with a clean cloth.
2. **Inspect the wheel material** for any damage. If wheel material shows excessive wear, consult the factory for a replacement.
3. **Pitch/Roll (Side) Wheel Adjustment (Refer to Figure 2-a on page 29)**
 - a. Loosen the side wheel attachment plates on both side of the carriage. Do not remove the screws.
 - b. With the side of the carriage facing you, push the wheel on the left upward and tighten the upper right attachment screw. Push the wheel on the right downward and tighten the lower left screw.
 - c. Repeat this procedure on the other side, again moving the left wheel up and the right wheel down.
 - d. Set the final side wheel position by moving the carriage toward the end of the extrusion, where access to the wheels is possible. Using a flat head screw driver, move the side wheels into contact with the appropriate edge of the slot, using the initial settings of left wheel up and right wheel down. Hold the wheel in place against the slot with the screwdriver and tighten the accessible plate screws.
 - e. Remove the carriage and tighten the remaining screws.
4. **Yaw (Top) Wheel Adjustments (Refer to Figure 2-b on page 29)**
 - a. Place the carriage in the body extrusion with the top slot facing you.
 - b. Preload the wheels. The top, or yaw wheels are adjusted via eccentric hex bushings. The wheels are brought into contact with the extrusion slot by turning the eccentrics clockwise with a socket. When adjusting yaw wheels, be sure that the two outer wheels contact the same side of the slot, while the center wheel contacts the opposite side.

Note: When mounting the actuator on its side, consider orienting the outer wheel downward to support the majority of the load.
 - c. Apply removable threadlocker just prior to adjusting. To tighten the wheel in place, tighten the mounting screw while holding the eccentric bushing in place.

5.) Inspect the Carriage**a. Carriage Alignment**

After all wheels have been preloaded, move the carriage back and forth to ensure that there are no alignment issues. Also inspect the carriage to ensure that it is situated parallel to the body extrusion. Allowing the carriage to run poorly aligned will cause premature wear on the bearings and on the strip guide bearings.

b. Magnitude of the Preload

When pulling the carriage out of the body, you should feel a slight bump when the carriage disengages. If the bump is significant, consider readjusting.

Important note: The tighter the contact with the wheels, the greater the effects of flat spots developing on the wheels at rest. It is only necessary to have slightly firm contact between the wheel and the extrusion. Excessive preload reduces the life of the bearings.

Questions?

Call the Automation Actuator Division Electromechanical
Applications Department at (330) 336-3511

Figure 2: Roller Bearing Carriage Preloading Diagrams

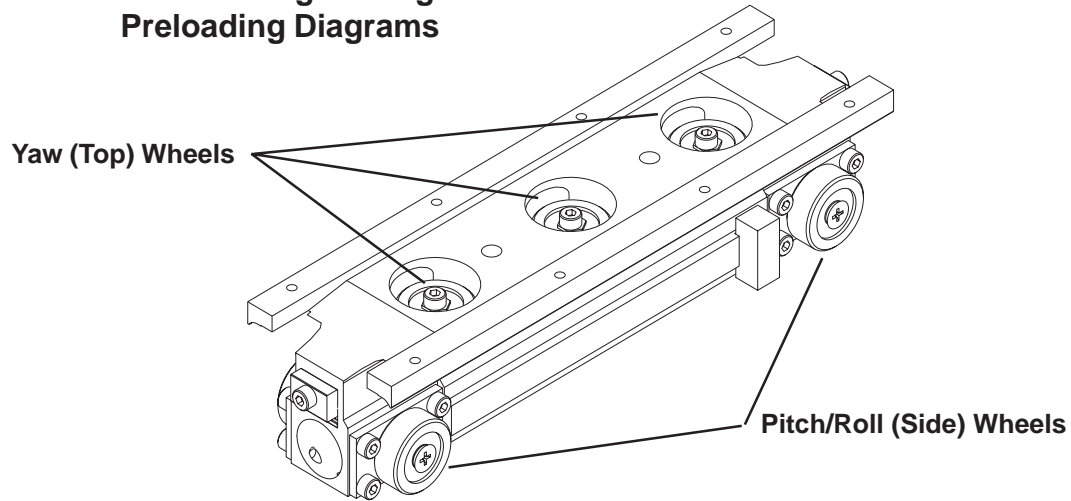

Figure 2-a: Pitch/Roll (Side) Wheel Preloading

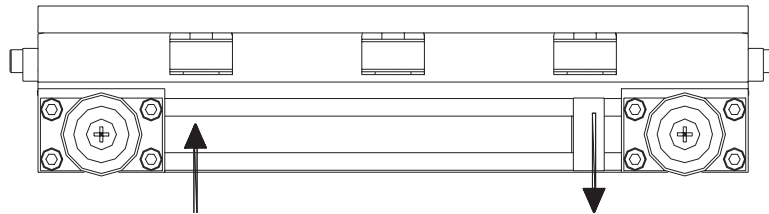
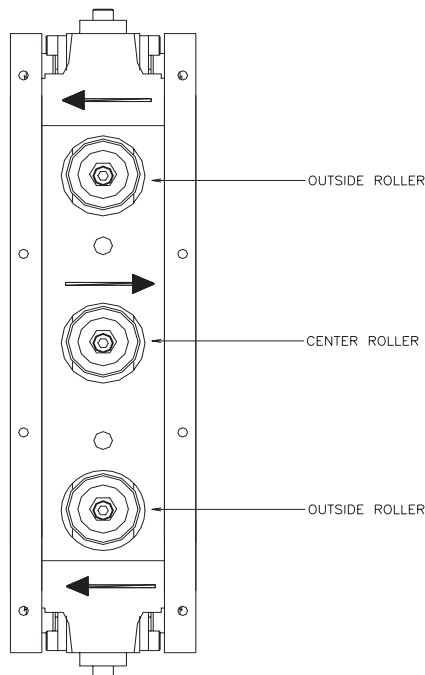

Figure 2-b: Yaw (Top) Wheel Preloading



Making Adjustments**Square Rail Carriages**

Square rail carriage units typically require no adjustment during the life of the actuator. Square rail bearing carriages are installed prelubricated, and under catalogued operating conditions should not require additional lubrication. Once the square rail bearing has exceeded its catalogued life, it may become necessary to replace the bearing set. Excessive carriage play and increased friction torque are indications of bearing wear. Normally, the ball or lead screw will end its useful life prior to the square rail bearing.

Replacement bearings are available from the Automation Actuator Division at (330) 336-3511. Please indicate the profile size and stroke of the actuator.

Drive Belt Tensioning for Belt Drive Versions

Under normal operating conditions (as specified in Catalog 1894), the drive belt of ER Series belt driven actuators may lose their factory set preload over time. As loss in preload may induce accuracy problems, belt slippage or rough motion. Should this occur during use, the belt drive tension may be reset following two methods. The first requires an inductive tension meter, available from AAD. It measures the rate of decay of the vibration of the belt after it is struck by measuring changes in induction in the steel reinforcement strands. The second method can be performed with simply a ruler and a weight with a known value, in which deflection of the belt is measured.

Tension Meter Method (requires Tension Meter available from AAD)

1. Remove the load attachment plate by loosening the eight screws.
2. Loosen the strip seal clamps at each end of the actuator and remove the strip seal.
3. Move the carriage to one end of the actuator; let it rest against the end of travel bumper.
4. Measure the unsupported length of the belt from the attachment clamp at the carriage to the center of the opposite end cap.
5. Select the mass of the belt based on the actuator size: ER32- 30 g/m, ER50- 48 g/m, ER80- 75 g/m.
6. Following the instructions provided in the meter's operating manual, measure and adjust the belt tension until the correct preload is achieved. Belt adjustments are made by turning the screw that attaches the belt clamp to the carriage. Clockwise rotation increases tension. Once the tension has been set, move the carriage to the other end and re-measure the belt to verify the tension. Factory tension values are: ER32- 108 N, ER50- 212 N, ER80- 336 N.

Force-Deflection Method

1. Remove the load attachment plate by loosening the eight screws.
2. Loosen the strip seal clamps at each end of the actuator and remove the strip seal.
3. Move the carriage to one end of the actuator; let it rest against the end of travel bumper.
4. Measure the unsupported length of the belt from the attachment clamp at the carriage to the center of the opposite end cap.
5. Insert a ruler into the actuator at the center point of the unsupported belt length. Note the height of the belt on the ruler.
6. Using the values in the table below, place the required weight at the center point of the belt and measure the deflection. Adjust the belt tension by turning the screw that attaches the belt clamp to the carriage. Clockwise rotation increases tension. Once the appropriate deflection has been achieved, move the carriage to the other end and re-measure the belt to verify the tension.

Actuator Series	Applied Load lb (N)	Belt Deflection inches (mm)
ER32	2 (9)	0.016 (0.41) x Unsupported belt length
ER50	3 (14)	0.013 (0.33) x Unsupported belt length
ER80	4 (18)	0.011 (0.28) x Unsupported belt length

Step Motors

ER Series Rodless Actuators are available with premounted step motors in three frame sizes. Motor data and motor connections are available for each size.

23 Frame Size Step Motors (S57-102 - Motor Code 21)

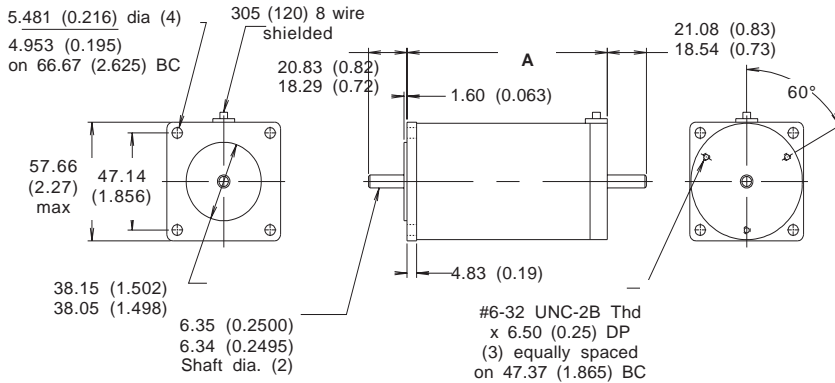

Size 23 Frame

Model	A
S57-102	4.0 (101.6)

Dimensions: inch (mm)

34 Frame Size Step Motor (S83-135 - Motor Code 31)

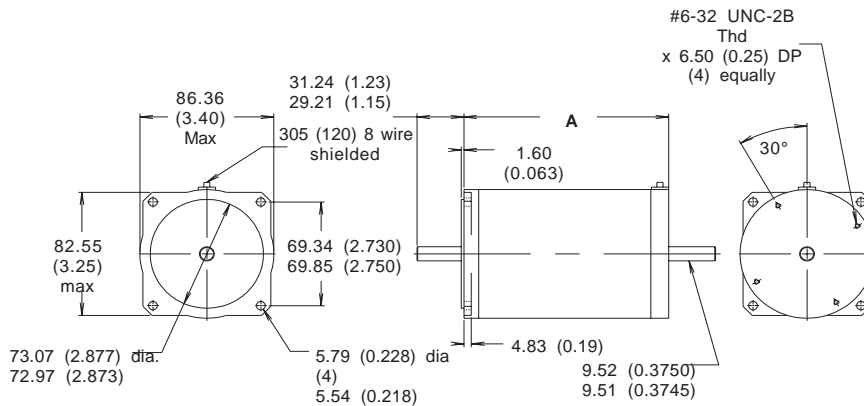

Size 34 Frame

Model	A
S83-135	5.2 (129.0)

Dimensions: inch (mm)

42 Frame Size Step Motor (S106-178 - Motor Code 41)

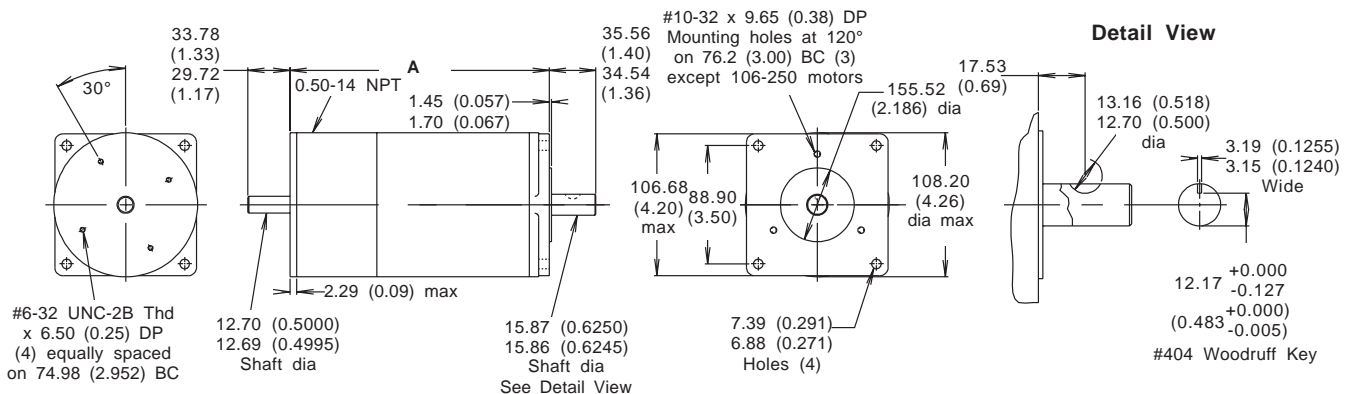

Size 42 Frame

Model	A
S106-178	195.32 (7.69)

Dimensions: inch (mm)

Conduit Connector Option (Motor Codes 22 and 32)

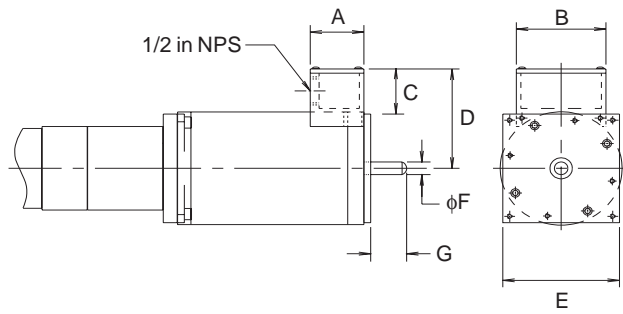

Motor Code	A	B	C	D	E	ØF	G
22	38.1 (1.50)	50.8 (2.00)	33.0 (1.30)	61.5 (2.42)	57.2 (2.25)	6.3 (0.25)	15.0 (0.59)
32	38.1 (1.50)	63.5 (2.50)	35.0 (1.38)	76.2 (3.00)	82.5 (3.25)	9.6 (0.38)	25.0 (1.00)

Dimensions: mm (inch)

Conduit Connector Option (Motor Code 42)

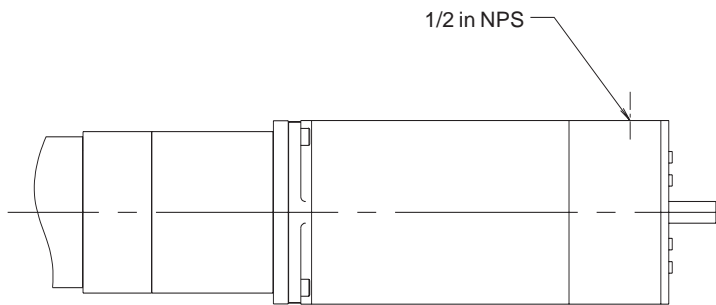

Step Motor Options

Brad Harrison Quick Disconnect Option (Motor Codes 23 and 33)

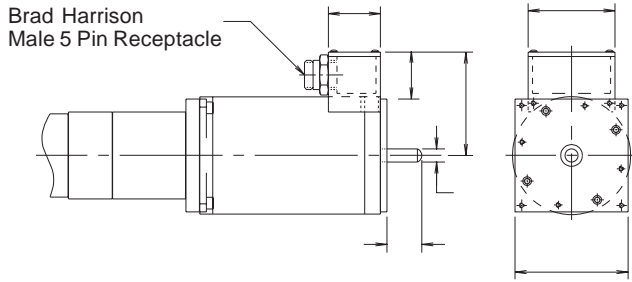

Motor Code	A	B	C	D	E	ØF	G
23	38.1 (1.50)	50.8 (2.00)	33.0 (1.30)	61.5 (2.42)	57.2 (2.25)	6.3 (0.25)	15.0 (0.59)
33	38.1 (1.50)	63.5 (2.50)	35.0 (1.38)	76.2 (3.00)	82.5 (3.25)	9.6 (0.38)	25.0 (1.00)

Dimensions: mm (inch)

Brad Harrison Quick Disconnect Option (Motor Code 43)

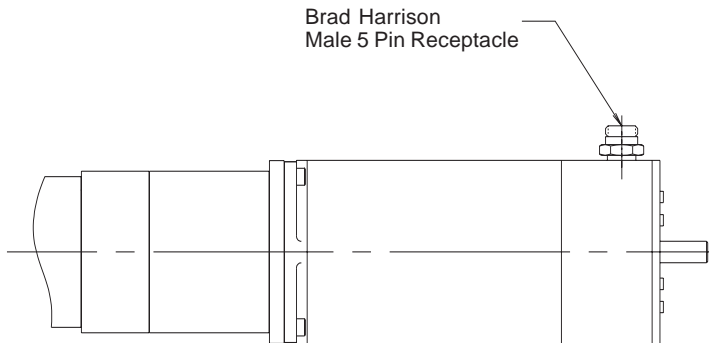

Step Motor Cable Color Coding

Motor Codes 21, 22, 31 and 32

Color	Assignment
Red	A+
Black	A-
Yellow	A Center Tap
Blue	A Center Tap
Shield	Ground
White	B+
Green	B-
Orange	B Center Tap
Brown	B Center Tap

Motor Codes 41 and 42

Color	Assignment
Red	A+
Black	A-
Shield	Ground
White	B+
Green	B-

Motor Codes 23, 33 and 43

Color	Assignment
Red	A+
Red-Black	A-
Green	Ground
Red-White	B+
Red-Orange	B-

Servo Motors

Servo Motors

ER Series Rodless Actuators are available with premounted brushless servo motors in two frame sizes. Motor data and motor connections are available for each motor.

23 Frame Size Servo Motors (SM233B - Motor Codes 22 and 23)

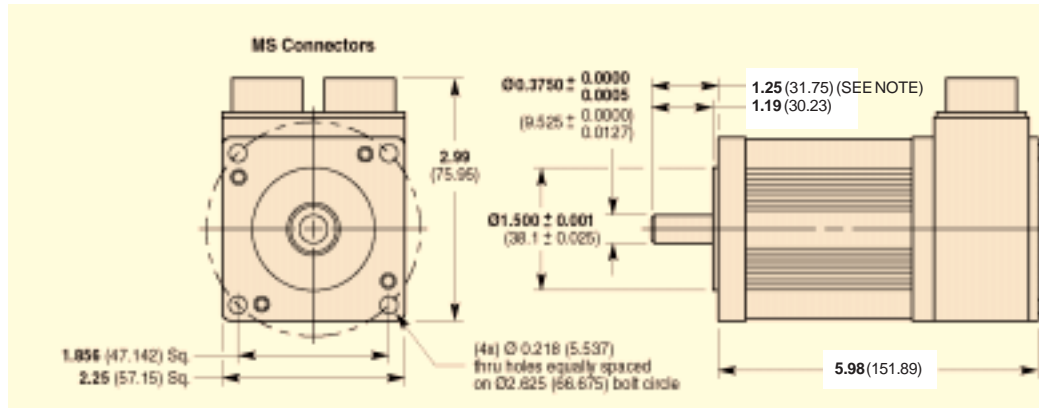

Note: Motor Codes 22 and 23 include a 1/8 inch keyway on the shaft.

Dimensions: inch (mm)

92 mm Frame Size Servo Motors (J092n - Motor Codes J1, J2 and J3)

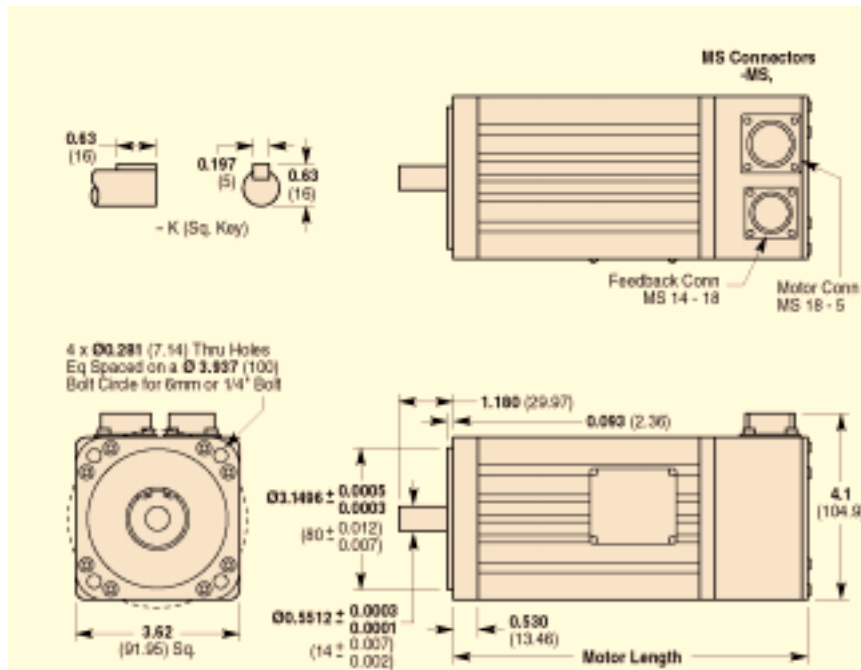

Dimensions: inch (mm)

Servo Motor Cable Color Coding

Motor Code 22

Cable Part Number:
23 TQ CABLE-10

Feedback Cable

Color	Assignment
Red	+5V
White	A+
Yellow	A-
Green	B+
Blue	B-
Orange	Z+
Brown	Z-
Black	Ground
Shield	Shield

Motor/ Hall Effect Cable

White-Green	Hall Ground
White-Blue	Hall +5V
White-Brown	Hall 1
White-Orange	Hall 2
White-Violet	Hall 3
Yellow	Motor Temp +
Yellow	Motor Temp -
Red-Yellow	Motor Phase A
White-Yellow	Motor Phase B
Black-Yellow	Motor Phase C
Green-Yellow	Motor Ground
Shield	Shield

Motor Code 23

Cable Part Number:
23 MS CABLE-10

Feedback Cable

Color	Assignment
Red	Stator 3
Black	Stator 1
Green	Stator 2
Blue	Stator 4
Brown	Rotor 1
White	Rotor 2
Yellow	Motor Temp +
Yellow	Motor Temp -
Shield	Shield

Motor Cable

Red-Yellow	Motor Phase A
White-Yellow	Motor Phase B
Black-Yellow	Motor Phase C
Green-Yellow	Motor Ground
Shield	Shield

Motor Codes J1, J2 and J3

Cable Part Number:
92 RS CABLE-25

Feedback Cable

Color	Assignment
Red	Stator 3
Black	Stator 1
Green	Stator 2
Blue	Stator 4
Brown	Rotor 1
White	Rotor 2
Yellow	Motor Temp +
Yellow	Motor Temp -
Shield	Shield

Motor Cable

Red-Yellow	Motor Phase A
White-Yellow	Motor Phase B
Black-Yellow	Motor Phase C
Green-Yellow	Motor Ground
Shield	Shield

DC Brush Motors

DC Brush Motors

ER Series Rodless Actuators are available with premounted DC brush motors in two frame sizes. Motor data and motor connections are available for each motor.

23 Frame Size DC Brush Motors (AD23A - Motor Code 21)

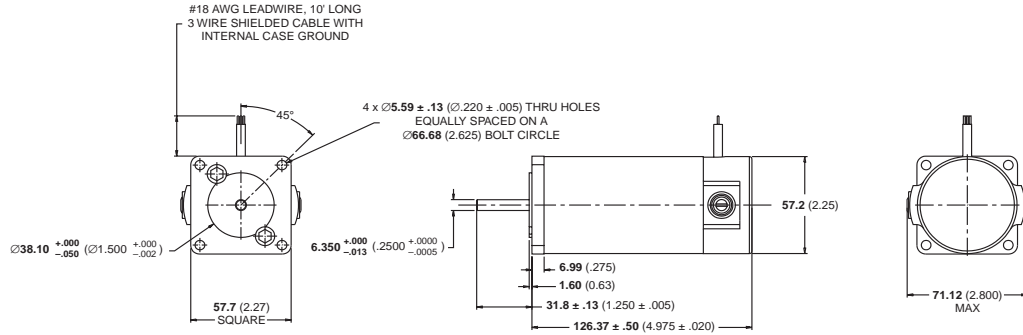

34 Frame Size DC Brush Motors (AD34A - Motor Code 31)

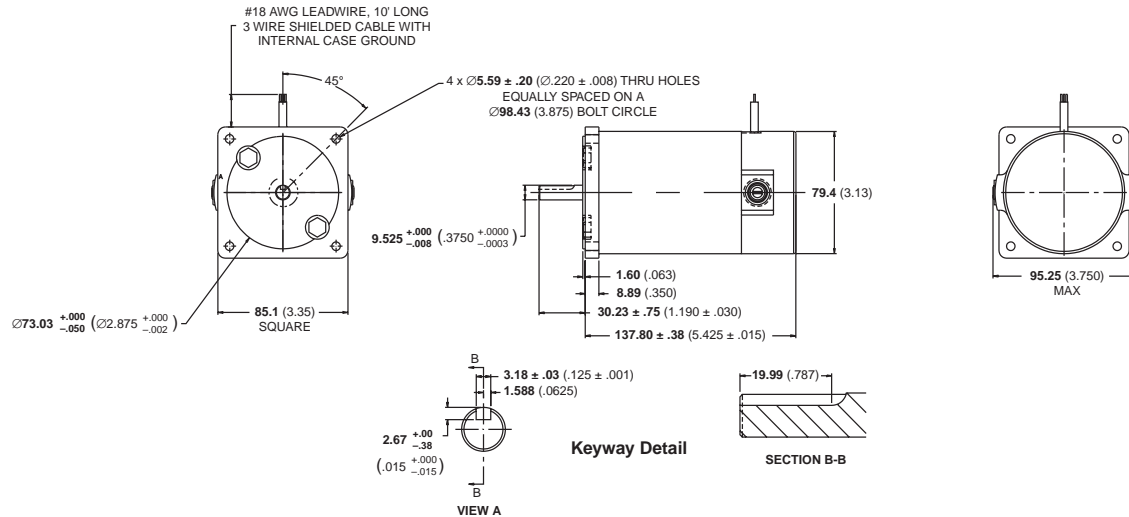

42 Frame Size DC Brush Motors (AD42A - Motor Code 41)

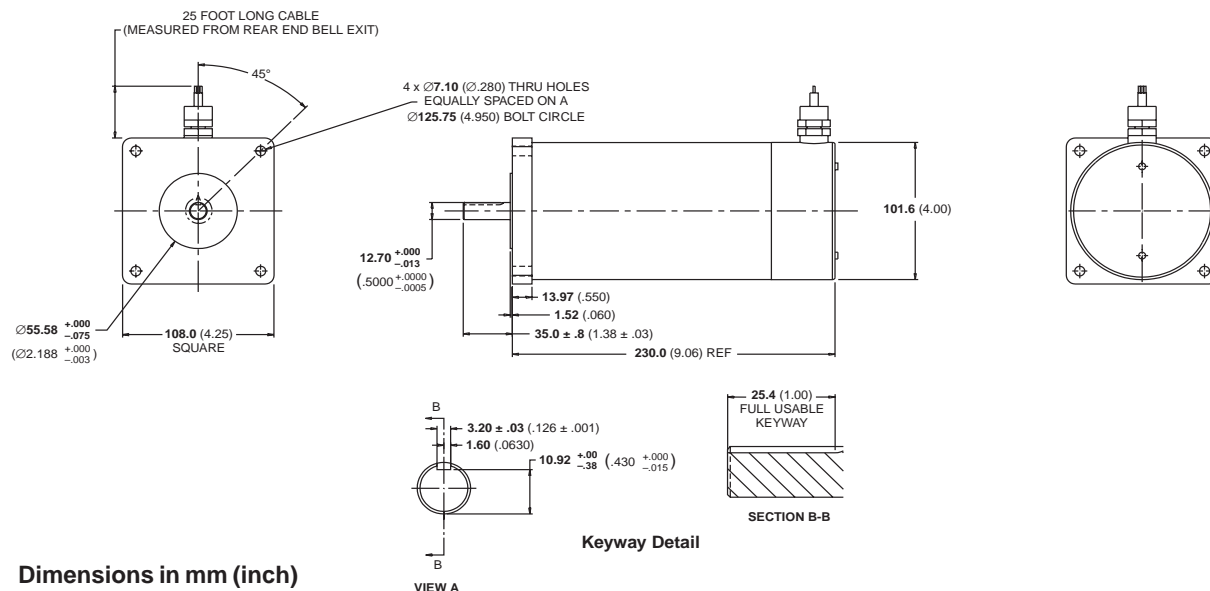

Dimensions in mm (inch)

DC Brush Motor Options

Conduit Connector Option (Motor Codes 22 and 32)

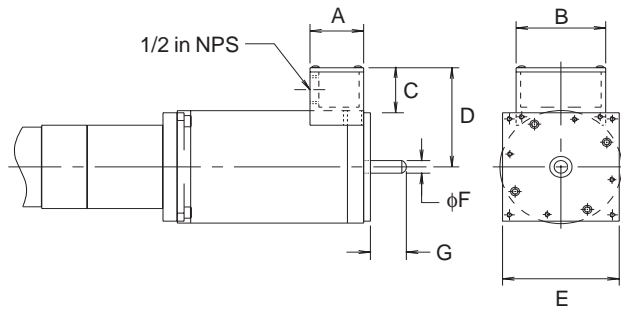

Motor Code	A	B	C	D	E	ØF	G
22	38.1 (1.50)	50.8 (2.00)	33.0 (1.30)	61.5 (2.42)	57.2 (2.25)	6.3 (0.25)	15.0 (0.59)
32	38.1 (1.50)	63.5 (2.50)	35.0 (1.38)	76.2 (3.00)	82.5 (3.25)	9.6 (0.38)	25.0 (1.00)

Dimensions: mm (inch)

Conduit Connector Option (Motor Code 42)

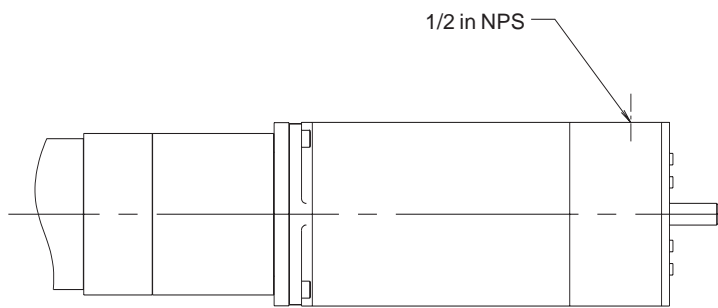

DC Brush Motor Options

Brad Harrison Quick Disconnect Option (Motor Codes 23 and 33)

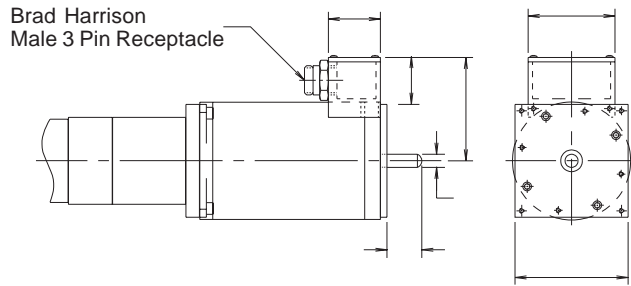

Motor Code	A	B	C	D	E	ØF	G
23	38.1 (1.50)	50.8 (2.00)	33.0 (1.30)	61.5 (2.42)	57.2 (2.25)	6.3 (0.25)	15.0 (0.59)
33	38.1 (1.50)	63.5 (2.50)	35.0 (1.38)	76.2 (3.00)	82.5 (3.25)	9.6 (0.38)	25.0 (1.00)

Dimensions: mm (inch)

Brad Harrison Quick Disconnect Option (Motor Code 43)

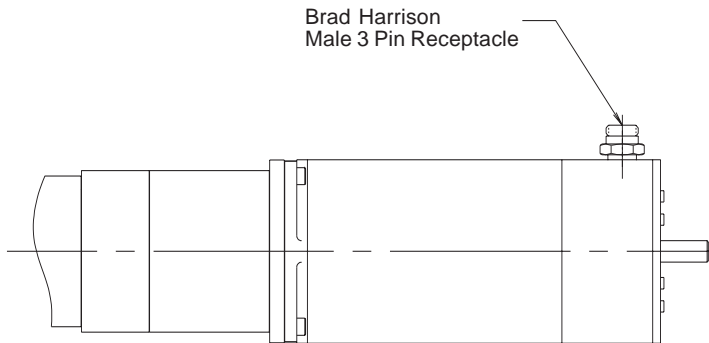

DC Brush Motor Cable Color Coding

Motor Codes 21, 22, 31 and 32

Color	Assignment
Blue	Motor +
Green/Yellow	Motor Ground
Brown	Motor -

Motor Codes 41 and 42

Color	Assignment
Red	Motor +
Green/Yellow	Motor Ground
Black	Motor -

Motor Codes 23, 33 and 43

Color	Assignment
Black	Motor +
Green/Yellow	Motor Ground
White	Motor -

Hall Effect Sensors

Two types of Hall effect sensors are available for use with ER Series actuators. The normally open sensor is typically used for mid-position sensing, such as homing applications. The normally closed sensor is generally used to indicate over-travel at the end of the stroke, and is used in a safety circuit to prevent damage to components caused by over-travel.

PNP Wiring Connection

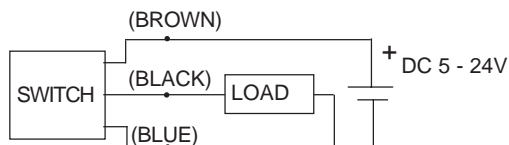

NPN Wiring Connection

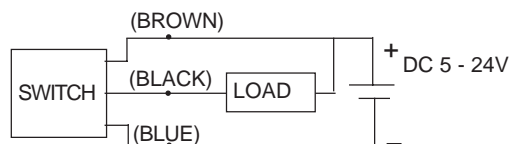

Note: End of travel sensors do not reduce available stroke.

The SX, PDX, ZETA6104 and APEX 615n controls use NPN sensors for Home and End-of-Travel.

PDX requires external +5VDC power supply for Hall Effect Sensors.

Specifications

Type:	Solid State Type (PNP or NPN)
Switching Logic:	Normally Open or Normally Closed
Supply Voltage Range:	5 - 24 VDC
Max. Switch Current:	150 mA
Current Consumption:	7 mA at 12 VDC, 14 mA at 24 VDC
Switching Response:	500 Hz Maximum
Residual Voltage:	0.8 V Maximum (150 mA)
Leakage Current:	10 uA Maximum
Insulation Resistance:	100 M Ohm min.
Min. Current for LED:	1mA
Operating Temperature:	-10° to 85°C (14° to 185°F)**
Lead Termination	1500 mm (60 in) or 150 mm (6 in) with connector
Industrial Protection:	IP66
Shock Resistance:	50 g's, 490 m/sec ²

BASIC CONNECTION DIAGRAM (PNP AND NPN)

- Brown: DC Voltage (5-24 VDC)
- Black: Limit Input
- Blue: Ground

Hall Effect Sensor Ordering Information

Sensor Only ER Series (without Clamp)

Hall Effect Sensor Information				
Part No.	Type	LED Color	Logic	Cable/Connector
SMH-1P	N.O.	Green	PNP	1.5m Black with Leads
SMH-1N	N.O.	Red	NPN	
SMC-1P	N.C.	Yellow	PNP	
SMC-1N	N.C.	White/Red	NPN	150mm Black with Connector*
SMH-1PC	N.O.	Green	PNP	
SMH-1NC	N.O.	Red	NPN	
SMC-1PC	N.C.	Yellow	PNP	
SMC-1NC	N.C.	White/Red	NPN	

* Sensor cable assemblies purchased separately.

Sensor with Clamp Included

Hall Effect Sensor Information				
Part No.**	Type	LED Color	Logic	Cable/Connector
SMHnn-1P	N.O.	Green	PNP	1.5m Black with Leads
SMHnn-1N	N.O.	Red	NPN	
SMCnn-1P	N.C.	Yellow	PNP	
SMCnn-1N	N.C.	White/Red	NPN	150mm Black with Connector*
SMHnn-1PC	N.O.	Green	PNP	
SMHnn-1NC	N.O.	Red	NPN	
SMCnn-1PC	N.C.	Yellow	PNP	
SMCnn-1NC	N.C.	White/Red	NPN	

* Sensor cable assemblies purchased separately.

** nn = 32, 50 or 80 to fit ER32, ER50 or ER80

Sensor Clamps (Ordered Separately)

Part Number	Actuator Size
SC32	ER32
SC50	ER50
SC80	ER80

Reed Switches

Reed Switches

Reed switches are available in a normally open or normally closed configuration. The low amp switch is suitable for connection to PLCs or other low current devices. The high amp switch can be used to drive sequencers, relays, coils, or other devices directly. Not compatible with TTL level I.O. Logic (switch will work with TTL level if wired backwards but LED will not light).

Integral Circuit for Switching Contact Protection

DC Operation

(Required for proper operation 24VDC)
Put Diode parallel to load (CR) with polarity as shown below.

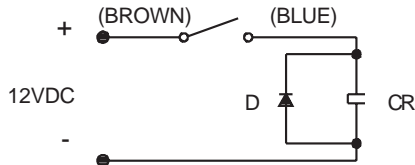

D: Diode: select a Diode with the breakdown voltage and current rating according to the load.
CR: Relay coil (under 0.5 W coil rating)

AC Operation (1.5 m Cable with Leads Only)

(Recommended for longer switch life 125VAC)
Put resistor and capacitor parallel to load (CR).

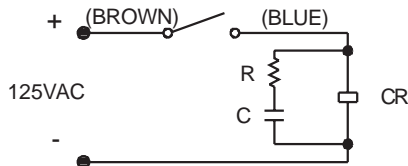

CR: Relay coil (under 2 W coil ratings)
R: Resistor under 1 K Ohm
C: Capacitor 0.1 μF

Note: Care must be taken not to exceed the Power Rating of the switch while still observing the voltage and current limitations.

Switch Ordering Information

Switches Only (ER Series w/o Clamp)

Reed Switch Information				
Part No.	Type	LED Color	Rating	Cable/Connector
SMR-1	N.O.	Green	Hi Amp	1.5m Grey with Leads
SMR-1L	N.O.	Red	Low Amp	
SMD-1L	N.C.	Yellow	Low Amp	150mm Grey with Connector*
SMR-1C	N.O.	Green	Hi Amp	
SMR-1LC	N.O.	Red	Low Amp	
SMD-1LC	N.C.	Yellow	Low Amp	

Switch Clamps (Ordered Separately)

Actuator Size	ER32	ER50	ER80
Clamp Part No.	SC32	SC50	SC80

Low Amp Reed Switch Specifications

Switching Logic:	Normally Open (SMR-1L) Normally Closed (SMD-1L)
Voltage Rating: (NO)	85-125 VAC or 6-24 VDC* 6-24 VAC, 6-24 VDC* (N.C.)
Power Rating:	AC or DC Resistive Load: 10 watts (N.O.) AC or DC Inductive Load: 5 watts (N.O.) AC or DC: 3 watts (N.C.)
Switching Current Range:	Resistive Load (PC, Sequencer): 5-40 mA (N.O.), 5-25 mA (NC) Inductive Load (Relay): 5-25 mA
Minimum Current for LED:	5 mA
Switching Response:	300 Hz (N.O.), 200 Hz (NC)
Breakdown Voltage:	200 VDC
Contact Resistance:	100 M Ohm min.
Operating Temperature:	-10° to 85°C (14° to 185°F)**
Lead Termination:	1500 mm (60 in) or 150 mm (6 in) with connector
Industrial Protection:	IP66
Shock Resistance:	30 g's, 300 m/sec ²

High Amp Reed Switch Specifications

Switching Logic:	Normally Open
Voltage Rating:	85-125 VAC or 6-24 VDC*
Power Rating:	AC or DC Resistive Load: 10 watts AC or DC Inductive Load: 5 watts
Switching Current Range:	Resistive Load (PC, Sequencer): 30-300 mA Inductive Load (Relay): 30-100 mA
Minimum Current for LED:	18 mA
Switching Response:	300 Hz Maximum
Breakdown Voltage:	200 VDC
Contact Resistance:	100 M Ohm min.
Operating Temperature:	-10° to 85°C (14° to 185°F)**
Lead Termination:	1500 mm (60 in) or 150 mm (6 in) with connector
Industrial Protection:	IP66
Shock Resistance:	30 g's, 300 m/sec ²

* Polarity is restricted for DC operation: (+) to Brown (-) to Blue
If these connections are reversed for TTL levels the contacts will close, but the LED will not light. Connector versions are for DC operation only.

** Exceeds temperature range for ET Series mechanical components.

Switches with Clamp Included

Reed Switch Information				
Part No.**	Type	LED Color	Rating	Cable/Connector
SMRnn-1	N.O.	Green	Hi Amp	1.5m Grey with Leads
SMRnn-1L	N.O.	Red	Low Amp	
SMDnn-1L	N.C.	Yellow	Low Amp	150mm Grey with Connector*
SMRnn-1C	N.O.	Green	Hi Amp	
SMRnn-1LC	N.O.	Red	Low Amp	
SMDnn-1LC	N.C.	Yellow	Low Amp	

*Switch cable assemblies purchased separately.
DC operation only.

** nn = 32, 50 or 80 to fit ER32, ER50 or ER80

Brake Option (E, F, G, H)

A brake option is available on the ER Series size 50 and 80 rodless actuators to prevent back driving of the bearing carriage when power is removed from the motor. The brake is a spring loaded, friction disc type that requires a separate power signal (24 VDC or 115 VAC) to the solenoid that releases the brake. The brake option attaches directly to the rear of the ball or Acme screw, preventing movement of the bearing carriage for static conditions. Options which mount to the rear of the actuator are not available with the brake option.

Specifications:

Mounting: Mechanically attached to end of lead screw and enclosed in a sealed metal housing.

Voltage: 24 VDC or 115 VAC (to release)

Current: ER50: 24 VDC = 0.542A,
115 VAC = 0.113A
ER80: 24 VDC = 0.667A,
115 VAC = 0.139A

Holding Torque: ER50: 3.36 Nm (30 lb-in)
ER80: 11.2 Nm (100 lb-in)

Connector: Flying leads 3.5 m (12 ft) or
Brad Harrison 3 pin connector
(4 m mating cable supplied)

Actuator	Lead (in)	Holding Force N (lb)
ER50-B01	1.000	735 N (165 lb)
ER50-B02	0.500	1560 N (350 lb)
ER50-B05	0.200	3560 N (800 lb)*
ER50-A05	0.200	3560 N (800 lb)*
ER80-B01	1.000	2560 N (575 lb)
ER80-B02	0.500	5120 N (1150 lb)
ER80-B04	0.250	7120 N (1600 lb)*
ER80-A04	0.250	7120 N (1600 lb)*

Ordering Information

Specify brake option, voltage, and connector style within complete actuator part number.

- E** 115 VAC with flying leads and cable gland
- F** 24 VDC with flying leads and cable gland
- G** 115 VAC with Brad Harrison and 4 m cable
- H** 24 VDC with Brad Harrison and 4 m cable

Notes:

- Brake option available on ET/ER50, ET/ER80, and ET/ER100.
- **To be used as static brake only! Not intended for dynamic braking.**
- Contact factory for use with inline or reverse parallel motor styles.
- Not available with mounting options that attach to rear of cylinder, including B, C, E, H, and N.
- External power supply required when used with Parker controls.

Dimensional Information:

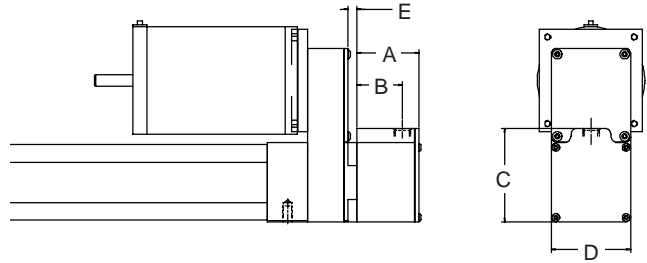

Cylinder	A	B	C	D	E
ET/ER50	50.0 (1.96)	36.3 (1.43)	75.0 (2.95)	63.5 (2.50)	7 (.276)
ET/ER80	76.0 (3.00)	60.0 (2.36)	95.3 (3.75)	95.3 (3.75)	10 (.39)
ET100***	82.6 (3.25)	66.5 (2.62)	136.7 (5.38)	127.0 (5.00)	10 (.39)

DIMENSIONS: mm

Inch equivalents for mm dimensions are shown in ().

Wiring information:

Flying lead:

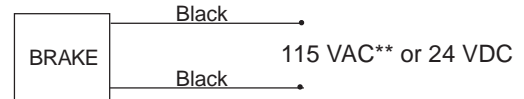

Connector version:

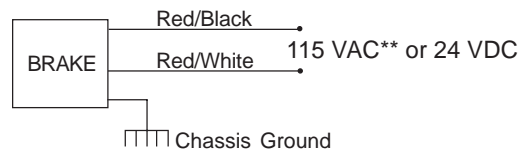

* Figure has been truncated at maximum catalog thrust rating of standard actuator. Consult factory for higher holding forces.

** Note: 115 VAC is rectified internally.

*** C & D dimensions exceed actuator envelope.

Offer Of Sale

The items described in this document and other documents or descriptions provided by Parker Hannifin Corporation, its subsidiaries and its authorized distributors are hereby offered for sale at prices to be established by Parker Hannifin Corporation, its subsidiaries and its authorized distributors. This offer and its acceptance by any customer ("Buyer") shall be governed by all of the following Terms and Conditions. Buyer's order for any such item, when communicated to Parker Hannifin Corporation, its subsidiary or an authorized distributor ("Seller") verbally or in writing, shall constitute acceptance of this offer.

1. Terms and Conditions of Sale: All descriptions, quotations, proposals, offers acknowledgments, acceptances and sales of Seller's products are subject to and shall be governed exclusively by the terms and conditions stated herein. Buyer's acceptance of any offer to sell is limited to these terms and conditions. Any terms or conditions in addition to, or inconsistent with those stated herein, proposed by Buyer in any acceptance of an offer by Seller, are hereby objected to. No such additional, different or inconsistent terms and conditions shall become part of the contract between, Buyer and Seller unless expressly accepted in writing by Seller. Seller's acceptance of any offer to purchase by Buyer is expressly conditional upon Buyer's assent to all the terms and conditions stated herein, including any terms in addition to, or inconsistent with those contained in Buyer's offer. Acceptance of Seller's products shall in all events constitute such assent.

2. Payment: Payment shall be made by Buyer net 30 days from the date of delivery of the items purchased hereunder. Amounts not timely paid shall bear interest at the maximum rate permitted by law for each month or portion thereof that the Buyer is late in making payment. Any claims by Buyer for omissions or shortages in a shipment shall be waived unless Seller receives notice thereof within 30 days after Buyer's receipt of the shipment.

3. Delivery: Unless otherwise provided on the face hereof, delivery shall be made F.O.B. Seller's plant. Regardless of the method of delivery, however, risk of loss shall pass to Buyer upon Seller's delivery to a carrier. Any delivery dates shown are approximate only and Seller shall have no liability for any delays in delivery.

4. Warranty: Seller warrants that the items sold hereunder shall be free from defects in material or workmanship for a period of 18 months from date of shipment from Parker Hannifin Corporation. **THIS WARRANTY COMPRISES THE SOLE AND ENTIRE WARRANTY PERTAINING TO ITEMS PROVIDED HEREUNDER. SELLER MAKES NO OTHER WARRANTY, GUARANTEE, OR REPRESENTATION OF ANY KIND WHATSOEVER. ALL OTHER WARRANTIES, INCLUDING BUT NOT LIMITED TO, MERCHANTABILITY AND FITNESS FOR PURPOSE, WHETHER EXPRESS, IMPLIED, OR ARISING BY OPERATION OF LAW, TRADE USAGE, OR COURSE OF DEALING ARE HEREBY DISCLAIMED.**

NOTWITHSTANDING THE FOREGOING, THERE ARE NO WARRANTIES WHATSOEVER ON ITEMS BUILT OR ACQUIRED WHOLLY OR PARTIALLY, TO BUYER'S DESIGNS OR SPECIFICATIONS.

5. Limitation of Remedy: SELLER'S LIABILITY ARISING FROM OR IN ANY WAY CONNECTED WITH THE ITEMS SOLD OR THIS CONTRACT SHALL BE LIMITED EXCLUSIVELY TO REPAIR OR REPLACEMENT OF THE ITEMS SOLD OR REFUND OF THE PURCHASE PRICE PAID BY BUYER, AT SELLER'S SOLE OPTION. IN NO EVENT SHALL SELLER BE LIABLE FOR ANY INCIDENTAL, CONSEQUENTIAL OR SPECIAL DAMAGES OF ANY KIND OR NATURE WHATSOEVER, INCLUDING BUT NOT LIMITED TO LOST PROFITS ARISING FROM OR IN ANY WAY CONNECTED WITH THIS AGREEMENT OR ITEMS SOLD HEREUNDER, WHETHER ALLEGED TO ARISE FROM BREACH OF CONTRACT, EXPRESS OR IMPLIED WARRANTY, OR IN TORT, INCLUDING WITHOUT LIMITATION, NEGLIGENCE, FAILURE TO WARN OR STRICT LIABILITY.

6. Changes, Reschedules and Cancellations: Buyers may request to modify the designs or specifications for the items sold hereunder as well as the quantities and delivery dates thereof, or may request to cancel all or part of this order, however, no such requested modification or cancellation shall become part of the contract between Buyer and Seller unless accepted by Seller in a written amendment to this Agreement. Acceptance of any such requested modification of cancellation shall be at Seller's discretion, and shall be upon such terms and conditions as Seller may require.

7. Special Tooling: A tooling charge may be imposed for any special tooling, including without limitation, dies, fixtures, molds and patterns, acquired to manufacture items sold pursuant to this contract. Such special tooling shall be and remain Seller's property notwithstanding payment of any charges by Buyer. In no event will Buyer acquire any interest in apparatus belonging to Seller which is utilized in the manufacture of the items sold hereunder, even if such apparatus has been specially converted or adapted for such manufacture and notwithstanding any charges paid by Buyer. Unless otherwise agreed, Seller shall have the right to alter, discard or otherwise dispose of any special tooling or other property in its sole discretion at any time.

8. Buyer's Property: Any designs, tools, patterns, materials, drawings confidential information or equipment furnished by Buyer, or any other items which become Buyer's property, may be considered obsolete and may be destroyed by Seller after two (2) consecutive years have elapsed without Buyer placing an order for the items which are manufactured using such property. Seller shall not be responsible for any loss or damage to such property while it is in Seller's possession or control.

9. Taxes: Unless otherwise indicated on the face hereof, all prices and charges are exclusive of excise, sales, use, property, occupational or like taxes which may be imposed by any taxing authority upon the manufacture, sale or delivery of the items sold hereunder. If any such taxes must be paid by Seller or if Seller is liable for the collection of such tax, the amount thereof shall be in addition to the amounts for the items sold. Buyer agrees to pay all such taxes or to reimburse Seller therefore upon receipt of its invoice. If Buyer claims exemption from any sales, use or other tax imposed by any taxing authority, Buyer shall save Seller harmless from and against any such tax, together with any interest or penalties thereon which may be assessed if the items are held to be taxable.

10. Indemnity For Infringement of Intellectual Property Rights: Seller shall have no liability for infringement of any patents, trademarks, copyrights, trade dress, trade secrets or similar rights except as provided in this Part 10. Seller will defend and indemnify Buyer against allegations of infringement of U.S. patents, U.S. trademarks, copyrights, trade dress and trade secrets (hereinafter 'Intellectual Property Rights'). Seller will defend at its expense and will pay the cost of any settlement or damages awarded in an action brought against Buyer based on an allegation that an item sold pursuant to this contract infringes the Intellectual Property Rights of a third party. Seller's obligation to defend and indemnify Buyer is contingent on Buyer notifying Seller within ten (10) days after Buyer becomes aware of such allegations of infringement, and Seller having sole control over the defense of any allegations or actions including all negotiations for settlement or compromise. If an item sold hereunder is subject to a claim that it infringes the Intellectual Property Rights of a third party, Seller may, at its sole expense and option, procure for Buyer the right to continue using said item, replace or modify said item so as to make it noninfringing, or offer to accept return of said item and return the purchase price less a reasonable allowance for depreciation. Notwithstanding the foregoing, Seller shall have no liability for claims of infringement based on information provided by Buyer, or directed to items delivered hereunder for which the designs are specified in whole or part by Buyer, or infringements resulting from the modification, combination or use in a system of any item sold hereunder. The foregoing provisions of this Part 10 shall constitute Seller's sole and exclusive liability and Buyer's sole and exclusive remedy for infringement of Intellectual Property Right.

If a claim is based on information provided by Buyer or if the design for an item delivered hereunder is specified in whole or in part by Buyer, Buyer shall defend and indemnify Seller for all costs, expenses or judgements resulting from any claim that such item infringes any patent, trademark, copyright, trade dress, trade secret or any similar right.

11. Force Majeure: Seller does not assume the risk of and shall not be liable for delay or failure to perform any of Seller's obligations by reason of circumstances beyond the reasonable control of Seller (hereinafter 'Events of Force Majeure'). Events of Force Majeure shall include without limitation, accidents, acts of God, strikes or labor disputes, acts, laws, rules or regulations of any government or government agency, fires, floods, delays or failures in delivery of carriers or suppliers, shortages of materials and any other cause beyond Seller's control.

12. Entire Agreement/Governing Law: The terms and conditions set forth herein, together with any amendments, modifications and any different terms or conditions expressly accepted by Seller in writing, shall constitute the entire Agreement concerning the items sold, and there are no oral or other representations or agreements which pertain thereto. This Agreement shall be governed in all respects by the law of the State of Ohio. No actions arising out of the sale of the items sold hereunder of this Agreement may be brought by either party more than two (2) years after the cause of action accrues.



Parker Hannifin Corporation
Automation Actuator Division
135 Quadral Drive
Wadsworth, Ohio 44281 USA
Tel: (330) 336-3511
Fax: (330) 334-3335
Web site: <http://www.parker.com/automation>