



Bulletin PM-ET01/USA

Maintenance Instructions & Parts List

Effective: January 1, 1998



ET Series
Stepper and Servo
Driven Linear
Actuators

Who'sWho
ER Series Rodless Actuators
Voice (330)336-3511 - Fax (330)334-3335

Tim Armstrong	Ext. 248	Order Entry & Expediting Technical Information
TBA	Ext. 228	Applications, Spare Parts
Erin Weitzel	Ext. 289	Programming
Chris Griffin	Ext. 277	Electro-Mechanical Product Sales Manager
Greg Haitz	Ext. 229	Marketing Manager
Jeff Cullman	Ext. 222	General Manager

 **WARNING**

FAILURE OR IMPROPER SELECTION OR IMPROPER USE OF THE PRODUCTS AND/OR SYSTEMS DESCRIBED HEREIN OR RELATED ITEMS CAN CAUSE DEATH, PERSONAL INJURY AND PROPERTY DAMAGE.

This document and other information from Parker Hannifin Corporation, its subsidiaries and authorized distributors provide product and/or system options for further investigation by users having technical expertise. It is important that you analyze all aspects of your application and review the information concerning the product or system in the current product catalog. Due to the variety of operating conditions and applications for these products or systems, the user, through its own analysis and testing, is solely responsible for making the final selection of the products and systems and assuring that all performance, safety and warning requirements of the application are met.

The products described herein, including without limitation, product features, specifications, designs, availability and pricing, are subject to change by Parker Hannifin Corporation and its subsidiaries at any time without notice.

Offer of Sale

The items described in this document are hereby offered for sale by Parker Hannifin Corporation, its subsidiaries or its authorized distributors. This offer and its acceptance are governed by the provisions stated on the separate page of this document entitled "Offer of Sale".

© Copyright 1997, Parker Hannifin Corporation, All Rights Reserved

Table of Contents

Description	Page No.
Product Information	4
Features	5
Ordering Information	6, 7
Exploded View	8
Parts List	9 - 13
Maintenance/Torque Table, Cleaning	14
Maintenance/Adjusting Timing Belt Tension	15
Lubricants, Motor Coupler and Pulley Spacing	16
Assembly Information	17
Pinouts - Servo Systems	18 - 21
Pinouts - Stepper Systems	21 - 23
Stepper Motor Options	24, 25
Hall Effect Sensors	26
Reed Switch Sensors	27
Reed Switch Specifications	28
Quick Connect and Brake Option	29

Product Information**ET Series Stepper and Servo Driven Linear Actuators****Maintenance Instruction & Parts List Electric Cylinder features:**

This publication provides maintenance instructions, replacement parts information, options information, and system connection tables for the ET Series.

The ET Series Linear Actuator offers robust, modular design and easy integration in a packaged electric cylinder. Available in four ISO mounting profile sizes, the ET Series can produce thrusts to 5300 lb and linear speeds to 60 inches per second. Combined with a Parker Hannifin stepper or servo system, the ET Series becomes a fully programmable linear actuator system.

ET Series Features

- Produced to hard metric ISO standards
- Four ISO mount sizes: 32mm, 50mm, 80mm, 100mm
- Angular contact thrust bearings at rear of screw
- Long length rod bearing
- Extruded, anodized aluminum body with integral switch/sensor grooves
- Unique anti-rotate nut bearing carriage
- Polyurethane bumper at ends of travel
- Low-friction ball bearing nut and quality rolled ball screw option
- Low-friction burnished lead screw with bronze nut option
- Ground and polished stainless steel rod
- Integral sensing magnet
- High quality flexible couplings
- High performance stepper and servo motors

Motor Systems

- Microstepping systems
- DC Brushless servo systems with encoder or resolver feedback
- User provided AC or DC motor systems

Control Systems

- Microprocessor-based programmable single and multi-axis stepper and servo controllers
- User-friendly 6000 and X languages from Compumotor

Features

Main Components Diagram

The figure below represents the main components of an ET Series Linear Actuator. Reverse parallel mounting shown for convenience.

Reverse-parallel cylinder

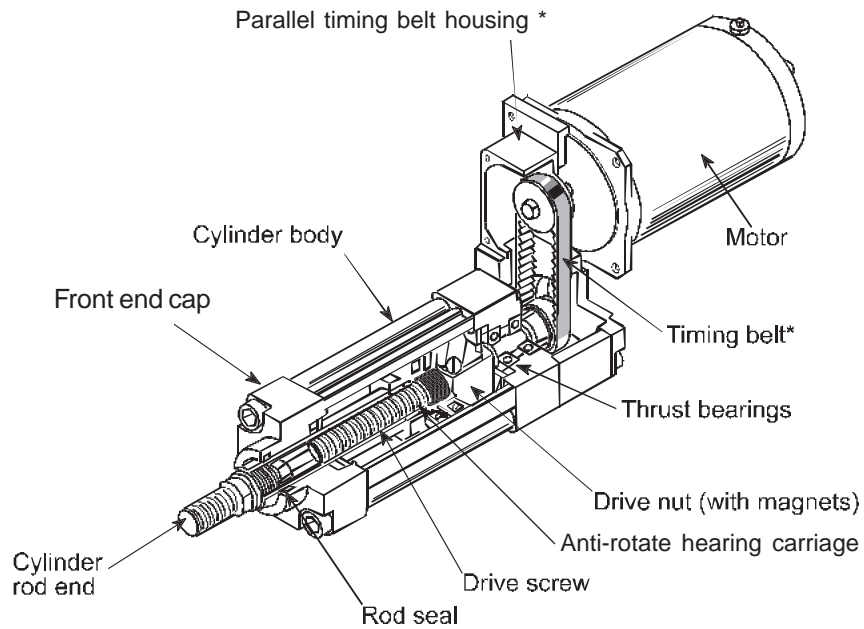

* Parallel cylinders only

Ordering Information

MODEL CODE AND ORDERING INFORMATION

Example: ETS50-B05PA21-FMAE600L-A

ETS 50 - B05 PA 2 1 -

Feature	Description	Catalog Page	Symbol
Series	Electro-Thrust Stepper Series	C1	ETS
	Electro-Thrust Brushless Servo Series	B1	ETB
Model/Size	32 mm	-	32
	50 mm	-	50
	80 mm	-	80
	100 mm	-	100
Drive Screw Type	Ball Screw, 1.875 in (47.6 mm) lead, Size 100	See Curves	B53
	Ball Screw, 1.000 in (25.4 mm) lead, Size 50 & 80	See Curves	B01
	Ball Screw, .500 in (12.70 mm) lead, Size 32, 50, 80, 100	See Curves	B02
	Ball Screw, .250 in (6.35 mm) lead, Size 80, 100	See Curves	B04
	Ball Screw, .200 in (5.08 mm) lead, Size 50	See Curves	B05
	Ball Screw, .125 in (3.18 mm) lead, Size 32	See Curves	B08
	Acme Screw, .250 in (6.35 mm) lead, Size 32, 80, 100	See Curves	A04
	Acme Screw, .200 in (5.08 mm) lead, Size 50	See Curves	A05
	Acme Screw, .125 in (3.18 mm) lead, Size 32	See Curves	A08
Motor Mounting Style	Inline, Direct Drive, Motor on End	D2	L
	Parallel Version, Timing Belt, Motor Position (1)	D2	P ¹
	Parallel, Timing Belt, Motor Position (2)	D2	M
	Parallel, Timing Belt, Motor Position (3)	D2	N
	Parallel, Timing Belt, Motor Position (4)	D2	Q
	Reverse Parallel, Timing Belt, Motor Position (1)	D2	R
	Reverse Parallel, Timing Belt, Motor Position (2)	D2	S
	Reverse Parallel, Timing Belt, Motor Position (3)	D2	T
	Reverse Parallel, Timing Belt, Motor Position (4)	D2	V
Drive Ratio	Inline Direct or Parallel, Ratio 1:1	See Curves	A
	Parallel, Ratio 1.5:1	See Curves	B ²
	Parallel, Ratio 2:1	See Curves	D ²
	Parallel, Ratio 1:1.5, Available on ET32 only	See Curves	Z
Stepper Motor Nominal Mounting Size	NEMA 23, Size 32 and 50	C62-63	2
	NEMA 34, Size 50 and 80	C62-63	3
	NEMA 42, Size 80 only	C62-63	4
	Special	-	9
Stepper Motor Style	No Motor, Flange and Coupling only	-	0
	Std. Motor, Cable Grommet, w/o Damper	C55	1
	Std. Motor, Conduit Connection, w/o Damper	C56	2
	Std. Motor, Brad Harrison Connector, w/o Damper	C57	3
	Std. Motor, Cable Grommet, w/ Damper	C58	4
	Std. Motor, Conduit Connection, w/ Damper	C58	5
	Std. Motor, Brad Harrison Connector, w/ Damper	C58	6
Special Motor*	-	9	

- ¹ Will obstruct standard (12 o'clock) switch groove orientation.
- ² Not available on ET32 or ET100. Not available with larger frame size motor on ET50 and ET80. [See chart on facing page.](#)
- ³ APEX motors purchased through AAD includes 7.5m (25 ft.) motor and resolver cable. SM233BE-LTQN option includes 23TQ Cable-10. SM233BR-LMSN option includes 23RS Cable-10.
- * Special motore/reducers must be mounted at factory.

Brushless Servo Motor Options ³ (ETB Series)	Description	Part Number	2	3	4
	NEMA 23, Flange & Coupling/Pulley only	B48-49	2	0	
	NEMA 34, Flange & Coupling/Pulley only	B48-49	3	0	
	SM233BE-LTQN, Size 32 & 50	B48-49	2	2	
	SM233BR-LMSN, Size 32 & 50	B48-49	2	3	
	APEX 60X Flange & Coupling/Pulley only, Size 50 & 80	B50-51	6	0	
	APEX 605 Motor, Size 50 & 80	B50-51	6	1	
	APEX 606 Motor, Size 50 (inline only) & 80	B50-51	6	2	
	APEX 610 Motor, Size 80	B50-51	6	3	
	APEX 620 Flange & Coupling/Pulley only, Size 100	B50-51	7	0	
	APEX 620, Size 80 (inline H.T. only) & 100	B50-51	7	1	
	APEX 640, Flange & Coupling/Pulley only, Size 100	B50-51	8	0	
	APEX 640, Size 100	B50-51	8	1	
	Special, Flange & Coupling/Pulley only*	-	9	0	

FMAE600L-A

Symbol	Catalog Page	Description	Feature	
A	-	Assigned by Factory	Design Series	
Omit	-	No linear Potentiometer	Linear Potentiometer	
L	-	Linear Potentiometer		
50	-	ET32, ET50, (1.97)	Stroke Length (in mm)	
100	-	ET32, ET50, ET80, ET100 (3.94 in)		
150	-	ET32, ET50, ET80, ET100 (5.91 in)		
200	-	ET32, ET50, ET80, ET100 (7.87 in)		
300	-	ET32, ET50, ET80, ET100 (11.81in)		
450	-	ET32, ET50, ET80, ET100 (17.72 in)		
600	-	ET32, ET50, ET80, ET100 (26.62 in)		
750	-	ET32, ET50, ET80, ET100 (29.53 in)		
1000	-	ET50, ET80, ET100 (39.37 in)		
1250	-	ET80, ET100 (49.21 in)		
1500	-	ET80, ET100 (59.05 in)		
Omit	-	No Brake		Brake Option ⁷
E	E4	115 VAC w/ Fling leads and cable gland on lead screw		
F	E4	24 VDC w/ Flying leads and cable gland on lead screw		
G	E4	115 VAC w/ Brad Harrison conn. & 4m cable		
H	E4	24 VDC w/ Brad Harrison conn. & 4m cable		
V	-	115 VAC w/ Flying leads and cable gland on stepper		
W	-	124 VDC w/ Flying leads and cable gland on stepper		
Y	-	115 VAC w/ Brad Harrison conn. & 4m cable on stepper		
Z	-	24 VDC w/ Brad Harrison conn. & 4m cable on stepper		
Omit	-	Standard (12 o'clock)	Body Orientation⁶	
A	-	3 o'clock		
B	-	6 o'clock		
C	-	9 o'clock		
M	D12	Male (Metric Standard)	Rod End	
F	D12	Female		
K	D12	Male - Imperial		
C	D13	Clevis		
S	D13	Spherical Rod Eye		
R ⁵	D15-20	Linear Rod Guide Module		
X	-	Special		
B ⁴	D3	Foot Mount (MS1)	Cylinder Mounting	
C ⁴	D10	Rear Clevis (MP2-R)		
D	D4-5	Trunnion (MT4)		
E ⁴	D9	Rear Eye (MP4)		
F	B48-49	Bottom Tap (MS4) (Standard)		
G	D8	Foot Side Lug		
H ⁴	D7	Rear Flange (MF2)		
J	D6	Front Flange (MF1)		
N ⁴	D7	Front & Rear Flange (MF1 & MF2)		
X	-	Special		

⁴ Not available with Inline (L) Motor Mounting.

⁵ Linear rod guide module may interfere with some switch groove orientations (Body Orientation A and C) on ET32, ET50 & ET80. Not compatible with G, J, or N mounting options.

⁶ Switch Groove Orientation as viewed from Cylinder Shaft End. May decrease side load capacity. ET100 has switch grooves on all four sides.

⁷ Not available on ET32 or NEMA 23 motors. Options (E,F,G & H) not compatible with rear mounting options (B,C,E,H & N). Options (V,W,Y & Z) not compatible damper or encoder.

Available Drive Ratio Combinations (Parallel only) (ET100 1:1 only)							
Size	S57-102	S83-135	S106-178	SM233B	APEX605	APEX606	APEX610
32	1:1, 1:1.5	-	-	1:1, 1:1.5	-	-	-
50	1:1, 1.5:1, 2:1	1:1, 1.5:1	-	1:1, 1.5:1	1:1	-	-
80	-	1:1, 1.5:1, 2:1	1:1, 1.5:1	-	1:1, 1.5:1	1:1, 1.5:1	1:1, 1.5:1

Parts list and exploded view

Order parts through the Automation Actuator Division in Wadsworth, Ohio, or through your local Parker Automation Technology Center (distributor).

PARTS COMMON TO INLINE AND PARALLEL MODEL (Page 9)

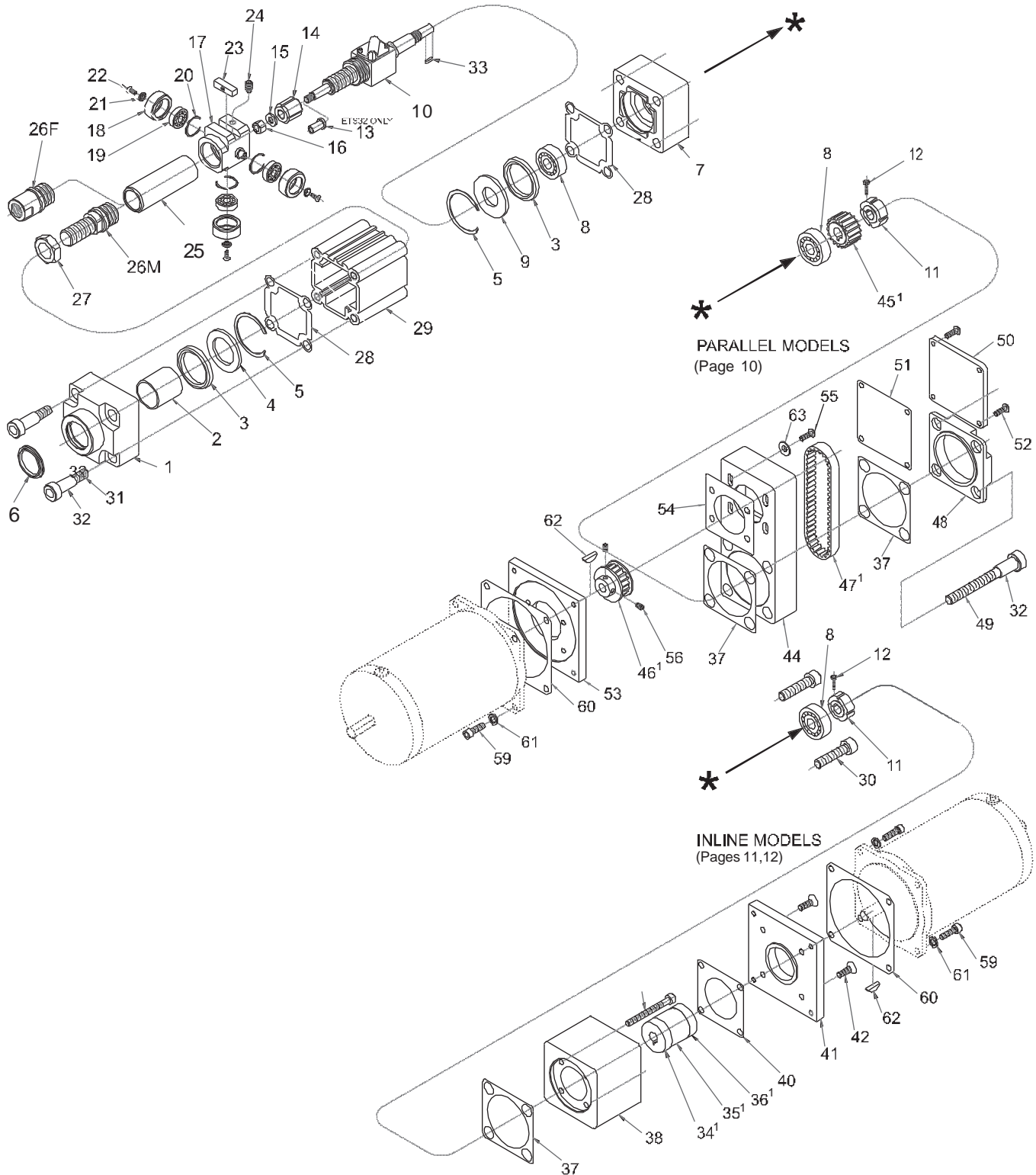

¹Parts listed on page 13.

Parts List

Actuator Common Parts List

Item	Description	Qty.	Part No.			
			ET 32	ET50	ET 80	ET 100
1	Head	1	ET32E01	ET50E01	ET80E01	ET100E01
2	Rod Bearing	1	RA340	RA335	RA341	RA365
3	Bumper	2	ET32M01	ET50M01	ET80M01	ET100M01
4	Washer	1	ET32M03	ET50M03	ET80M03	ET100M03
5	Snap Ring	2	BNVH-112	BNVH-162	BNVH-275	BNVH-337
6	Rod Seal	1	RS422	RS423	RS424	RS453
7	End Cap-Standard	1	ET32E02	ET50E02	ET80E02	ET100E02
7T	End Cap-Trunnion Mount	1	ET32E02T	ET50E02T	ET80E03	ET100E02T
8	Screw Support Bearing	2	RA373	RA336	RA342	RA362
9	Washer	1	ET32M02	ET50M02	ET80M02	ET100M06
10	Drive Screw	1	TS****N*****	TS****N*****	TS****N*****	TS****N*****
11	Bearing Locknut	1	ET32R07	B8777	B8776	B8866
12	Cap Screw	1	CS-CM3X0.5-008			
13	Sleeve	1	ET32R08	NA	NA	NA
14	Screw End Bearing	1	ET32R06	ET50R06	ET80R06	ET100R06
15	Washer	1	ET32R09	ET50R09	ET80R09	ET100R09
16	Elastic Locknut	1	B3118	B3117	B3119	B3121
17	Nut Retainer	1	ET32R03	ET50R03	ET80R03	ET100R03
18	Roller Cover	3	ET32R10-0813	ET50R10-1000	ET80R10-1500	ET100R10-2000
19	Bearing	3	RA328	RA338	RA330	RA331
20	Snap Ring	3	BNVH-62	BNVH-75	BNVH-112	BNVH-137
21	Bearing Retainer	3	ET32R04	ET32R04	ET80R04	ET100R04
22	Flat Head Cap Screw	3	CFT-CM3X0.5-008	CFT-CM3X0.5-008	CF-CM6X1.0-016	CF-CM6X1.0-016
23	Magnet	1	ET32M10	ET50M10	ET50M10	ET100M10
24	Brass Tip Set SCrew	1	SB-CM4X0.7-006	SB-CM6X1-008	SB-CM8X1.25-008	SB-CM8X1.25-008
25	Cylinder Rod	1	ET32R01-****	ET50R01-****	ET80R01-****	ET100R01-****
26M	Cylinder Rod End - M	1	ET32R05	ET50R05	ET80R05	ET100R05
26F	Cylinder Rod End - F	1	ET32R12	ET50R12	ET80R12	ET100R14
26K	Cylinder Rod End - K	1	ET32R13	ET50R15	ET80R13	ET100R15
27M	Jam Nut - M	1	509-2	509-4	509-5	509-17
27K	Jam Nut - K	1	NHJ-C04420-Z	NHJ-C06318-Z	NHJ-C07516-Z	NHJ-C10014
28	Gasket	2	ET32M04	ET50M04	ET80M04	ET100M04
29	Cylinder Body	1	ET32C****	ET50C****	ET80C****	ET100C****
30	Cap Screw (in line only)	4	CS-CM6X1.0-035	CS-CM8X1.25-040	CS-CM10X1.5-055	CS-CM10X1.5-080
31	Tie Rod Bolt	4	SC-CM6X1.0-020	SC-CM8X1.25-030	B8805-M10-30	B8805-M10-45
32	Tie Rod Nut	8	32-27015	50-27015	80-27015	80-27015
33L	Key-Inline	1	B8534M2-06	B8534M2-08	B8534M5-14	B8534M8-20
33P	Key-Parallel	1	B8534M2-20	B8534M3-20	B8534M5-32	B8534M8-40
33B	Key-Brake	1		B8534M2-14	B8534M5-32	B8534M8-40
34	Coupler End Fitting	1	SEE PAGE 13			
35	Coupler Sleeve	1				
36	Coupler End Fitting	1				
37	Gasket	2				
45	Pulley - No Flange	1	SEE PAGE 13			
46	Pulley - Double Flange	1				
47	Timing Belt	1				
57	Acme Screw Adapter	1	ET32R11	NA	ET80R11	ET100R13
58	Acme Nut	1	TNA06***	TNA10***	TNA16***	TNA24***

Parts List

ET Series

Motor Mounting Parts List for Parallel Units

	Part No.	ET 32 Series	ET 50 Series	ET 80 Series	ET 100 Series
C O M M O N	37	ET32M05	ET50M05	ET80M05	ET100M05
	44	ET32E06	ET50E06	ET80E06	ET100E06
	48	ET32E07	ET50E07	ET80E07	ET100E07
	49	B8805-M6-50	B8805-M8-60	B8805-M10-90	B8805-M10-140
	50	ET32E10	ET50E10	ET80E10	ET100E10
	51	ET32M08	ET50M08	ET80M08	ET100M08
	52	CB-CM3X0.5-008-Z	CB-CM4X0.7-012-Z	ESF4005-12	ESF4005-12
	54	ET32M09	ET50M09	ET80M09	ET100M09
	55	CB-CM4X0.7-010	CB-CM5X0.8-010	CB-CM6X1.0-012	CB-CM8X1.25-020
	63	B2128-M4	B2128-M5	B2128-M6	B2128-M8
S57-102	53	ET32E08	ET50E08	NA	NA
	59	CS-CM5X0.8-012-Z	CS-CM5X0.8-012-Z		
	60	ET50M06	ET50M06		
	61	WS-SLR-CM05-Z	WS-SLR-CM05-Z		
S83-135	53	NA	ET50E09	NA	NA
	59		CS-CM5X0.8-012-Z		
	60		ET80M13		
	61		WS-SLR-CM05-Z		
S106-178	53	NA	NA	ET80E09	ET100E15
	59			CS-CM6X1.0-016-Z	CS-CM6X1.0-025-Z
	60			ET80M12	ET80M12
	61			WS-SLR-CM06-Z	WS-SLR-CM06-Z
SM233	53	ET32E08	ET50E08	NA	NA
	59	CS-CM5X0.8-016-Z	CS-CM5X0.8-012-Z		
	60	ET50M06	ET50M06		
	61	WS-SLR-CM05-Z	WS-SLR-CM05-Z		
ML-2340B	53	ET32E08	ET50E08	NA	NA
	59	CS-CM5X0.8-012-Z	CS-CM5X0.8-012-Z		
	60	ET50M06	ET50M06		
	61	WS-SLR-CM05-Z	WS-SLR-CM05-Z		
ML-3450B	53	NA	ET50E09	ET80E08	
	59		CS-CM5X0.8-016-Z	CS-CM5X0.8-016-Z	
	60		ET80M13	ET80M13	
	61		WS-SLR-CM05-Z	WS-SLR-CM05-Z	
APEX605 APEX606 APEX610	53	NA	ET50E17	ET80E16	NA
	59		CS-CM6X1.0-025-Z	CS-CM6X1.0-020-Z	
	60		ET50M11	ET50M11	
	61		WS-SLR-CM06-Z	WS-SLR-CM06-Z	
APEX620	53	NA	NA	NA	ET100E08
	59				CS-CM8X1.25-030-Z
	60				ET100M12
	61				ESF1108
APEX640	53	NA	NA	NA	ET100E09
	59				CS-CM10X1.5-040-Z
	60				ET100M13
	61				ESF1110

Parts List

Motor Mounting Parts List for Inline Units

	Part No.	ET 32 Series	ET 50 Series	ET 80 Series	ET 100 Series
S57-102	38	ET32E04	ET50E04		
	39	CS-CM3X0.5-035	CS-CM5X0.8-050		
	40	ET32M05	NA		
	41	ET32E05	NA		
	42	CFT-CM3X0.5-012	NA		
	59	CS-CM5X0.8-012-Z	CS-CM5X0.8-016-Z		
	60	ET50M06	ET50M06		
	61	WS-SLR-CM05-Z	WS-SLR-CM05-Z		
	62	NA	NA		
S83-135	38		ET50E04	ET80E04	
	39		CS-CM5X0.8-050	CS-CM6X1.0-080	
	40		ET50M06	NA	
	41		ET50E05	NA	
	42		CS-CM5X0.8-016	NA	
	59		CS-CM5X0.8-016-Z	CS-CM5X0.8-016-Z	
	60		ET80M13	ET80M13	
	61		WS-SLR-CM05-Z	WS-SLR-CM05-Z	
	62		NA	NA	
S106-178	38			ET80E04	
	39			CS-CM6X1.0-080	
	40			ET80M05	
	41			ET80E05	
	42			CF-CM5X0.8-020	
	59			CS-CM6X1.0-020-Z	
	60			ET80M12	
	61			WS-SLR-CM06-Z	
	62			B8544-404	
SM233	38	ET32E04	ET50E15		
	39	CS-CM3X0.5-035	CS-CM5X0.8-050		
	40				
	41	ET32E09			
	42	CS-CM3X0.5-025			
	59	CS-CM5X0.8-018-Z	CS-CM5X0.8-016-Z		
	60	ET50M06	ET50M06		
	61	WS-SLR-CM05-Z	WS-SLR-CM05-Z		
	62				
ML-2340B	38	ET32E04	ET50E15		
	39	CS-CM3X0.5-035	CS-CM5X0.8-050		
	40				
	41	ET32E09			
	42	CS-CM3X0.5-025			
	59	CS-CM5X0.8-018-Z	CS-CM5X0.8-016-Z		
	60	ET50M06	ET50M06		
	61	WS-SLR-CM05-Z	WS-SLR-CM05-Z		
	62	B8534008-.75	B8534008-.75		

Parts List

ET Series

Motor Mounting Parts for Inline Units

	Part No.	ET 32 Series	ET 50 Series	ET 80 Series	ET 100 Series
ML-3450B	38		ET50E04	ET80E26	
	39		CS-CM5X0.8-050	CS-CM6X1.0-080	
	40		ET50M06		
	41		ET50E05		
	42		CS-CM5X0.8-016		
	59		CS-CM5X0.8-020-Z	CS-CM5X0.8-020-Z	
	60		ET80M13	ET80M13	
	61		WS-SLR-CM05-Z	WS-SLR-CM05-Z	
	62		B8534008-.75	B8534008-.75	
APEX605 APEX606 APEX610	38		ET50E04	ET80E14	
	39		CS-CM5X0.8-050	CS-CM6X1.0-080	
	40		ET50M05		
	41		ET50E11		
	42		CF-CM5X0.8-016		
	59		CS-CM6X1.0-025-Z	CS-CM6X1.0-025-Z	
	60		ET50M11	ET50M11	
	61		WS-SLR-CM06-Z	WS-SLR-CM06-Z	
	62		B8534M5-20	B8534M5-20	
APEX620	38				ET100E04
	39				CS-CM8X1.25-110
	40				
	41				
	42				
	59				CS-CM8X1.25-035-Z
	60				ET100M12
	61				ESF1108
	62			B8534M8-35	
APEX640	38				ET100E05
	39				CS-CM8X1.25-090
	40				ET100M05
	41				ET100E13
	42				CS-CM8X1.25-025
	59				CS-CM10X1.5-040-Z
	60				ET100M13
	61				ESF1110
	62			B8534M8-35	

Parallel Series Timing Belts & Pulleys

		Part No.		
		45	46	47
Model	Motor	Driven Pulley	Drive Pulley	Belt
ETS32-***PA2	S57-102M0	B8789-20	B8793F-20	B8801-15-56
ETS32-***PZ2	S57-102M0	B8789-16	B8793F-24	B8801-15-56
ETB32-***PA2	ML2340B-10	B8789-20	B8793-2038	B8801-15-56
ETB32-***PZ2	ML2340B-10	B8789-16	B8793-2438	B8801-15-56
ETS50-***PA2	S57-102M0	B8790-28	B8793F-28	B8801-15-78
ETS50-***PB2	S57-102M0	B8790-33	B8793F-22	B8801-15-78
ETS50-***PD2	S57-102M0	B8790-36	B8793F-18	B8801-15-78
ETS50-***PA3	S83-135M0	B8791-18	B8794F-18	B8802-15-51
ETS50-***PB3	S83-135M0	B8791-21	B8794F-14	B8802-15-51
ETB50-***PA2	ML2340B-10	B8790-28	B8793-2838	B8801-15-78
ETB50-***P82	ML2340B-10	B8790-33	B8793-2238	B8801-15-78
ETB50-***PA3	ML3450B-10	B8791-18	B8794-1850	B8802-15-51
ETB50-***PA6	APEX605-M0	B8791-18	B8794-1855	B8802-15-51
ETS80-***PA3	S83-135M0	B8792-28	B8794F-28	B8802-15-66
ETS80-***PB3	S83-135M0	B8792-33	B8794F-22	B8802-15-66
ETS80-***PD3	S83-135M0	B8792-36	B8794F-18	B8802-15-66
ETS80-***PA4	S106-178M0	B8792-28	B8795F-28	B8802-25-70
ETS80-***PB4	S106-178M0	B8792-33	B8795F-22	B8802-25-70
ETB80-***PA3	ML3450B-10	B8792-28	B8795-2850	B8802-25-66
ETB80-***PB3	ML3450B-10	B8792-33	B8795-2250	B8802-25-66
ETB80-***PD3	ML3450B-10	B8792-36	B8795-1850	B8802-25-66
ETB80-***PA6	APEX605, 606 & 610	B8792-28	B8795-2855	B8802-25-66
ETB80-***PB6	APEX605, 606 & 610	B8792-33	B8795-2255	B8802-25-66
ETB100-***PA**	APEX620 & 640	B8869-25	B8870-25	B8868-36-60

Inline Series Couplers

		Part No.		
		34	35	36
Model	Motor	Screw Couple	Sleeve/Spider	Motor Coupler
ETS32-***LA2*	S57-102M0	GCM100602	GC12-SU	GC102500
ETB32-***LA2*	ML2340B-10	RG5M090602	RGS0998	RG5093813
ETS50-***LA2*	S57-102M0	GCM180802	GC19-SU	GC182500
ETS50-***LA3*	S83-135M0	GCM180802	GC19-SU	GC183800
ETB50-***LA2*	ML2340B-10	RG5M140802	RGS1 498	RGS143813
ETB50-***LA3*	ML3450B-10	RG5M140802	RG51498	RGS145013
ETB50-***LA6*	APEX605, 606	RG5M140802	RG S1498	RGSM14140
ETS80-***LA3*	S83-135M0	GCM401405	GC42-SU	GC403800
ETS80-***LA4*	S106-178M0	GCM401405	GC42-SU	GC406313
ETB80-***LA3*	ML3450 B-10	1RG5M1914051	RG51998	RG5195013
ETB80-***LA6*	APEX605, 606 & 610	RG5M191405	RGS1998	RGSM191405
ETB100-***LA**	APEX620&640	RG5M242008	RG52498	RG5M242408

Maintenance/Torque Table, Cleaning

The following maintenance information is contained in this section:

Torque table - Provides torque specification for all items requiring specific torque values. When assembling parts, make sure to use the recommended torque value listed in this table. If a torque value is not listed, use industry standard torque for the fastener/metal combinations. (page 14)

Cleaning - Provides external cleaning information. (page 14)

Adjusting timing belt tension - Provides a procedure for timing belt adjustment. (page 15)

Lubrication - Provides lubrication information. (page 16)

Motor coupler and pulley spacing - Provides motor coupler (for inline motors) and pulley (for parallel motors) installation information. (page 16)

Assembly information - Provides information necessary for replacement of specific components requiring adhesives during the assembly process. (page 17)

Torque Specifications

	Part	Torque Specifications (Max.)											
		ET 32 Series			ET 50 Series			ET 80 Series			ET 100 Series		
Description	Numbers *	Size	in-lb	ft-lbs	Size	in-lb	ft-lbs	Size	in-lb	ft-lbs	Size	in-lb	ft-lbs
Rod Assembly	17,25,26	-	530	44	-	1325	110	-	2650	221	-	4200	165
Roller Retainer FHSCS	22	M3	11	1	M3	11	1	M6	85	7	M6	85	7
Elastic Locknut	16	M5	50	4	M6	85	7	M8	210	18	M12	725	60
Bearing Ret. Locking SHCS	12	M3	11	1	M3	11	1	M5	50	4	M5	50	4
Cylinder Tie Bolts	30 & 32	M6	85	7	M8	210	18	M10	415	35	M10	415	35
Coupler End SHSS (Servo)	34,36	M2,5	11	1	M3	11	1	M4	41	3	M6	85	7
Coupler End SHSS (Stepper)	34,36	M4	41	3	M6	85	7	M6	85	7	-	-	-
Motor Adapter SHCS	39	M3	11	1	M5	50	4	M6	85	7	M8	210	18
Motor Adapter FHSCS/SHCS	42	M3	11	1	M5	50	4	M5	50	4	M8	210	18
Motor Mounting Bolts	59	M5	50	4	M5	50	4	M5	50	4			
					M6	85	7	M6	85	7			
Parallel Flange BHSCS	55	M4	41	3	M5	50	4	M6	85	7	M8	210	18
Parallel Cover BHSCS	52	M3	11	1	M4	41	3	M5	50	4	M5	50	4
Drive Pulley SHSS/SHCS	56	M2,5	11	1	M2,5	11	1	M3	11	1	M6	85	7
					M3	11	1	M4	41	3			

*This part number is the number used in the parts listing as well as any maintenance tasks contained in this manual.

Cleaning Information

Clean cylinder body, front end cap, etc., using a clean cloth. Use only a mild, non-corrosive cleaning agent. Remove any sludge, deposits, or other foreign substances from the surface of the cylinder.

NOTE: Do not use high-pressure wash down or steam-lance type cleaning systems.

Adjusting Timing Belt Tension

Procedure

1. Remove four button head cap screws (52).
2. Remove cover (50) and gasket (51) from end cap (44).
3. Loosen four button head cap screws (55). Loosen just enough to allow motor to move freely.
4. Adjust belt (47) tension. Refer to Belt tension table for deflection values. A belt with correct tension should deflect the listed value with proper finger pressure at the mid-span of the belt.
 - Using belt tension tool
 - Attach belt tension tool assembly to mounting plate (53). Turn adjustment screw as required to properly tension the timing belt. (Tensioning procedure supplied with tool.)
 - By hand
 - a. Maintaining proper force on the belt at the middle of the belt span (see chart), tighten button head cap screws (55).
 - b. Check for proper belt deflection.
5. Visually inspect for proper seating of belt teeth in pulley grooves.
6. Torque the four button head cap screws (55). (Refer to the torque values chart located earlier in this section.)
7. Place gasket (51) and cover (50) on end cap (44), securing with four button head cap screws (52).
8. Torque the four button head cap screws (52) as required. (Refer to the torque values chart located earlier in this section.)

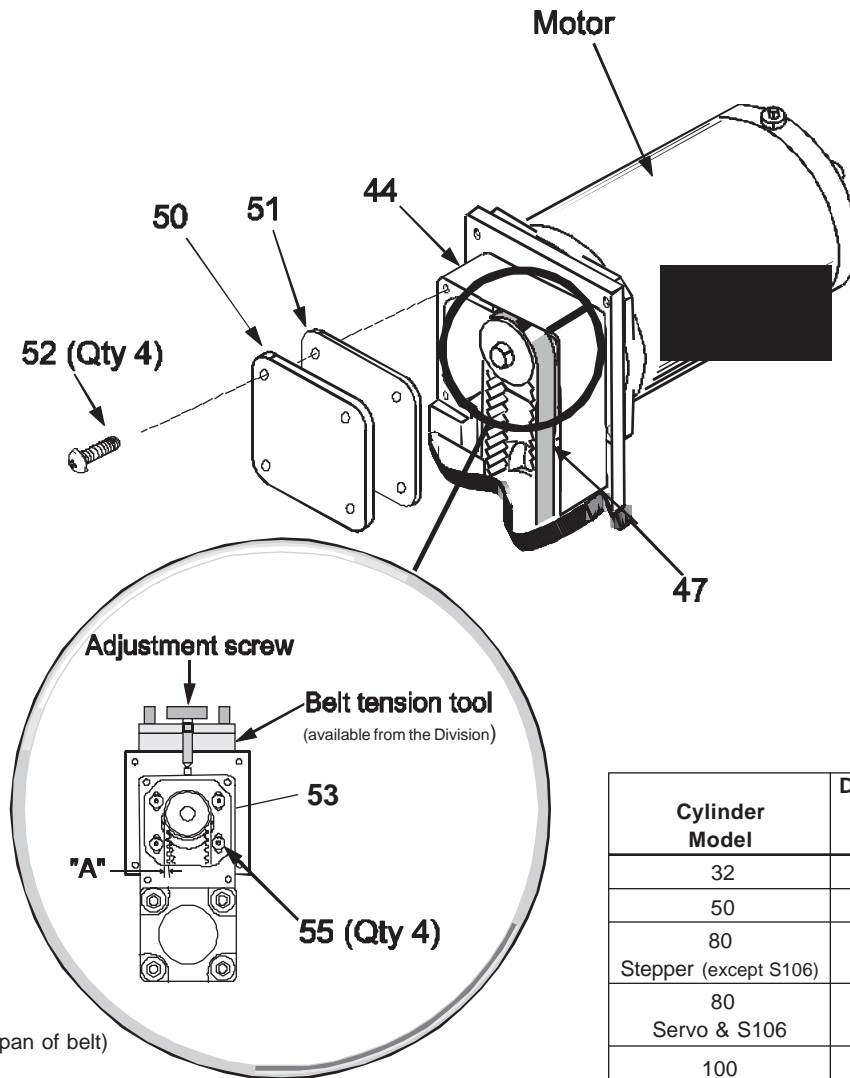

Cylinder Model	Dimension "A" Deflection Value	Force (lb)
32	0.034"	.4 - .7
50	0.048"	.9 - 1.75
80 Stepper (except S106)	0.061"	.9 - 1.75
80 Servo & S106	0.061"	1.6 - 2.8
100	0.086"	12 - 13

Lubricants, Motor Coupler and Pulley Spacing ET Series

Lubrication

Approved lubricants:

- MagnaLube (part number 1331815-000-01), 1.5 oz tube
- Thompson Linear Lube 14.5 oz tube

NOTE: Use appropriate personal protection equipment when using lubricants (refer to applicable MSDS). Unit is lubricated from the factory for the design life of the cylinder.

Motor coupler and pulley spacing

1. Determine type of motor (inline or parallel).
2. Referring to the appropriate illustration and specification table, assemble coupler to motor shaft using Loctite 609. Make sure to measure the “A” dimension from the mounting face of the motor. Do not measure off of the pilot. Tighten set screw (if applicable).
3. Make sure to torque motor mounting hardware as necessary (if applicable). [Refer to page 14](#) for torque values.

NOTE: Use precautions contained with Loctite or any other adhesive used in assembly.

Pulley Spacing

Parallel Motors dimension “A”				
Motor	ET32	ET50	ET80	ET100
S57-102	0.176	0.193	—	—
S83-135	—	0.190	0.255	—
S106-178	—	—	0.193	—
SM16	0.364	—	—	—
SM23	0.176	0.193	—	—
ML-2340B	0.176	0.193	—	—
ML-3450B	—	0.190	0.193	—
APEX605	—	0.410	0.311	—
APEX606	—	—	0.311	—
APEX610	—	—	0.311	—
APEX620	—	—	—	0.395
APEX640	—	—	—	0.513

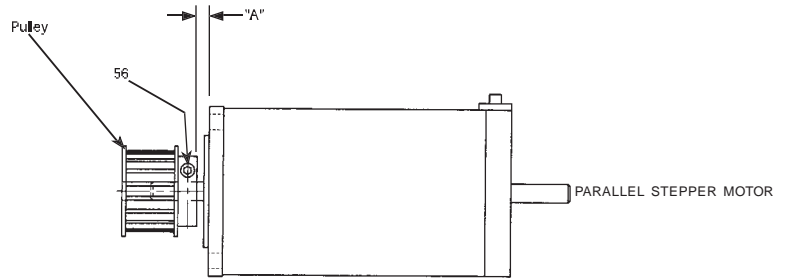

Coupler Spacing

Inline Stepper Motors dimension “A”		
Model	Motor	Dimension
ETS32	S57-102	0.331
ETS50	S57-102	0.102
ETS50	S83-135	0.693
ETS80	S83-135	0.134
ETS80	S106-178	0.528

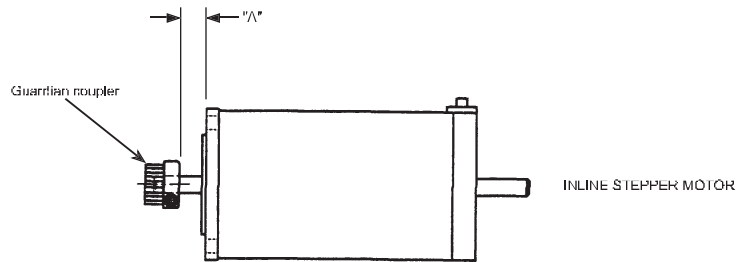



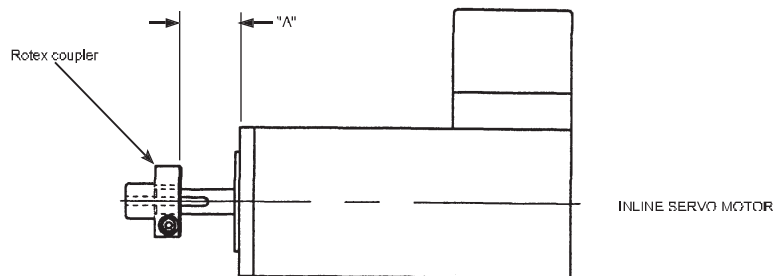

Inline Servo Motors dimension “A”		
Model	Motor	Dimension
ETB32	SM16	0.984
ETB32	SM233	0.450
ETB32	ML-2340B5	0.876
ETB50	SM-233	0.773
ETB50	ML-2340B5	0.773
ETB50	ML-3450B	0.852
ETB50	APEX605 & 606	0.749
ETB80	ML-3450B	0.356
ETB80	APEX605, 606, & 610	0.218
ETB80	APEX620	0.995
ETB100	APEX620	0.807
ETB100	APEX640	0.857



Assembly Information

The following parts, when assembled, require the use of industrial lubricants or adhesives as indicated.

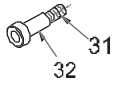
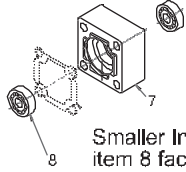
Part	Description	Lubricant/Adhesive
 <p>26F</p>	Cylinder rod-end - Female	Loctite 271
 <p>22</p>	Flat Head Cap Screw	Loctite 242
 <p>24</p>	Set screw	Loctite 242
 <p>26M</p>	Cylinder rod-end - Male	Loctite 271
 <p>31 32</p>	Tie rod bolt and tie rod nut	Loctite 271 <i>Apply between the tie rod bolt and nut only.</i>
 <p>8</p> <p>Smaller Inner Race of item 8 faces End Cap (7).</p>	Screw support bearing	Grease <i>If not sealed</i>

NOTE: Use appropriate personal protection equipment when using adhesives (refer to applicable MSDS).

Servo System Connector Information

BLH and BLHX Connections

User I/O (15-Pin D socket)

Pin No.	Signal
1	VEL 2
2	VEL 1
3	- 15V
4	Logic ground
5	Reset
6	+ 15V
7	Tachometer out
8	Reserved
9	Fault
10	CHA+
11	CHA -
12	CHB +
13	CHB -
14	CHZ +
15	CHZ -

Motor connector (5-Pin screw terminal)

Pin No.	Signal
1	B1
2	B2
3	Ground
4	A1
5	A2

AC Supply Connector (3-Way screw terminal)

Pin No.	Signal
1	AC in
2	AC in
3	Ground

Positioner I/O (23-Pin screw terminal) (BLHX only)

Pin No.	Signal
1	Vs
2	Limit (+)
3	Limit (-)
4	HOME
5	STOP
6	AUX. -IN
7	IN1
8	IN2
9	IN3
10	IN4
11	IN5
12	IN6
13	IN7
14	IN8
15	IN9
16	IN10
17	OUT1
18	OUT2
19	OUT3
20	OUT4
21	OUT5
22	OUT6
23	Ground

RP240 (5-Pin screw terminal) (BLHX only)

Pin No.	Signal
1	+5VDC (Out)
2	ISO Ground
3	Rx
4	Tx
5	Shield

RS232 (3-Pin screw terminal) (BLHX only)

Pin No.	Signal
1	Rx
2	Tx
3	ISO ground

AUX-in 24VDC (2-Pin screw terminal)

Pin No.	Signal
1	+ 24V in
2	Ground (0V)

External encoder (9-Pin D socket) (BLHX only)

Pin No.	Signal
1	A + (Step +)
2	A - (Step -)
3	B + (Dir +)
4	B - (Dir -)
5	Z +
6	Z -
7	+ 5 VDC
8	Ground
9	Ground

TQ10 Connections

Connector 1 (10-Pin removable connector)

Pin No.	Type	Signal
1	Input	Enable In
2	Ground	Enable Gnd
3	Output	Fault Out+
4	Output	Fault Out-
5	Input	Reset In
6	Ground	Reset Gnd
7	Input	Command+
8	Input	Command-
9	Ground	Command Shield
10	Ground	Ground

Connector 2 (10-Pin removable connector)

Pin No.	Type	Signal
1	Ground	Ground
2	Output	+15VDC
3	Output	-15VDC
4	Ground	Hall Gnd
5	Output	Hall +5VDC
6	Input	Hall 1
7	Input	Hall 2
8	Input	Hall 3
9	Input	Motor Temp+Drive Input Power
10	Input	Motor Temp-Voltage

TQ10SD Connections**Connector 1 (10-Pin connector)**

Pin No.	Type	Signal
1	Output	Velocity Monitor
2	Input	CPE 2 (Position Error 2)
3	Input	Step+
4	Input	Direction+
5	Input	Deriv. Gain Reduction
6	Input	Integral Gain Off
7	Input	CPE 1 (Position Error 1)
8	Ground	Ground
9	Input	Step-
10	Input	Direction-

Connector 2 (10-Pin removable connector)

Pin No.	Type	Signal
1	Input	Shutdown+
2	Input	Shutdown-
3	Ground	Encoder Ground
4	Output	Encoder +5VDC
5	Input	Encoder A+
6	Input	Encoder A-
7	Input	Encoder B+
8	Input	Encoder B-
9	Output	Reserved
10	Output	Reserved

Connector 3 (10-Pin removable connector)

Pin No.	Type	Signal
1	Input	Enable In
2	Ground	Enable Gnd
3	Output	Fault Out+
4	Output	Fault Out-
5	Input	Reset In
6	Ground	Reset Gnd
7-10	Not Used	

Connector 4 (10-Pin removable connector)

Pin No.	Type	Signal
1-3	Not Used	
4	Ground	Hall Gnd
5	Output	Hall +5VDC
6	Input	Hall 1
7	Input	Hall 2
8	Input	Hall 3
9	Input	Motor Temp +
10	Input	Motor Temp -

APEX Drives/Controllers**APEX10, APEX20, and APEX40****Control connections (13-Pin removable connector)**

Pin No.	Signal
1	Reset
2	Ground
3	Velocity Integrator Enable
4	Enable
5	Fault
6	Ground
7	Command (+)
8	Command (-)
9	Tachometer out
10	Ground
11	+ 15V
12	Ground
13	- 15V

Power connections (4 Pin-high power removable connector)

Pin No.	Signal
1	Line 1
2	Line 2
3	Line 3
4	Earth

Resolver connections (13-Pin removable connector)

Pin No.	Signal
1	Shield
2	Stator 1
3	Stator 2
4	Stator 3
5	Stator 4
6	Rotor 1
7	Rotor
8	Motor Temperature (+)
9	Motor Temperature (-)
10	Fault relay (+)
11	Fault relay (-)
12	Feedback (+)
13	Feedback (-)

Motor connections (7-Pin high power removable connector)

Pin No.	Signal
1	VBUS (+)
2	Regen Resistor
3	VBUS (-)
4	Phase A
5	Phase B
6	Phase C
7	Motor ground

Encoder connections (7-Pin removable connector)

Pin No.	Signal
1	CHA +
2	CHA -
3	CHB +
4	CHB -
5	CHZ +
6	CHZ -
7	Ground

Pinouts - Servo Systems**Resolver connections (13-Pin removable connector)**

Pin No.	Signal
1	Shield
2	Stator 1
3	Stator 2
4	Stator 3
5	Stator 4
6	Rotor 1
7	Rotor
8	Motor Temperature (+)
9	Motor Temperature (-)
10	Fault relay (+)
11	Fault relay (-)
12	Feedback (+)
13	Feedback (-)

Motor connections (7-Pin high power removable connector)

Pin No.	Signal
1	VBUS (+)
2	Regen Resistor
3	VBUS (-)
4	Phase A
5	Phase B
6	Phase C
7	Motor ground

Encoder connections (7-Pin removable connector)

Pin No.	Signal
1	CHA +
2	CHA -
3	CHB +
4	CHB -
5	CHZ +
6	CHZ -
7	Ground

APEX6151, APEX6152, and APEX6154**External Encoder (9-Pin screw terminal)**

Pin No.	Signal
1	Shield
2	ISO Ground
3	Z- Channel
4	Z+ Channel
5	B- Channel
6	B+ Channel
7	A- Channel
8	A+ Channel
9	+5 VDC (out)

Motor connections (7-Pin screw terminal)

Pin No.	Signal
1	V bus (+)
2	Regen Resistor
3	V bus (-)
4	Phase A
5	Phase B
6	Phase C
7	Motor ground

Auxiliary (14-Pin screw terminal)

Pin No.	Signal
1	Reserved
2	Reserved
3	Trigger A
4	Trigger B
5	Output (-)A
6	ISO Ground
7	+5 VOC (out)
8	Output Pull-Up
9	Input Pull-Up
10	Auxiliary Pull-Up
11-14	Not used

Power input (4-Pin screw terminal)

Pin No.	Signal
1	Earth
2	Neutral
3	N/A
4	Line

Programmable I/O Pin Outs (14-Pin screw terminal)

Pin No.	I/O Connector
1	Input#16
3	Input#15
5	Input#14
7	Input#13
9	Input#12
11	Input#11
13	Input#10
15	Input#9
17	Output #8
19	Output #7
21	Output #6
27	Input #7
29	Input #6
31	Input #5
33	Output #4
35	Output #3
37	Output #2
39	Output #1
41	Input #4
43	Input #3
45	Input #2
47	Input #1

Pinouts - Servo, Stepper Systems

RP240 (5-Pin screw terminal)

Pin No.	Signal
1	+5 VDC (Out)
2	ISO Ground
3	Rx
4	Tx
5	Shield

Limits (4-Pin screw terminal)

Pin No.	Signal
1	ISO Ground
2	Home
3	Negative
4	Positive

RS232 (3-Pin screw terminal)

Pin No.	Signal
1	Rx
2	Tx
3	ISO ground

Stepper System Connector Information

ZETA Series

**ZETA 4 Drive Microstepping Systems
Indexer Connector (25-Pin D socket)**

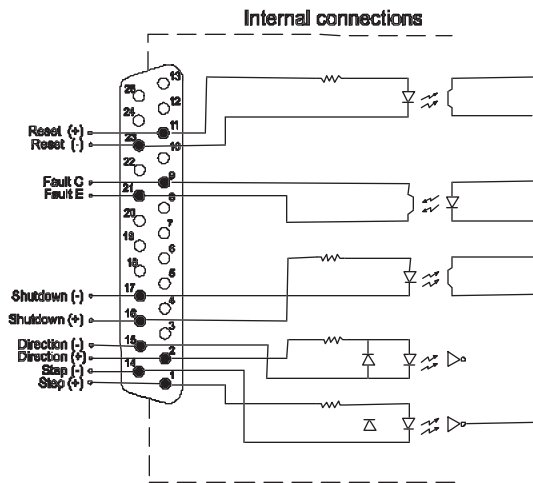

**Stepper and Servo Driven Linear Actuators
ET Series**

Motor connector (9-Pin screw terminal)

Pin No.	Signal
1	Interlock
2	A (-) center tap
3	A (+)
4	A (-)
5	Gnd
6	B (+)
7	B (-)
8	B (-) center tap
9	Interlock

ZETA6104 Microstepping Systems

COM1 (4-Pin screw terminal)

Pin No.	Signal
1	Rx
2	Tx
3	Ground
4	Shield

COM2 (5-Pin screw terminal)

Pin No.	Signal
1	+5V DC (out)/Rx+
2	Ground/RX
3	Rx/Tx+
4	Tx/Tx-
5	Shield/Ground

Encoder (9-Pin screw terminal)

Pin No.	Signal
1	Shield
2	Ground
3	Z (-)
4	Z (+)
5	B (-)
6	B (+)
7	A (-)
8	A (+)
9	+5 VDC (out)

Limits 1/2 (4-Pin screw terminal)

Pin No.	Signal
1	Ground
2	Home
3	Negative
4	Positive

Pinouts - Stepper Systems**I/O (9-Pin screw terminal)**

Pin No	Signal
1	Trigger A
2	Trigger B
3	Output A
4	Ground
5	Pulse cut-off
6	+5 VDC (out)
7	Output pull-up
8	Input pull-up
9	Auxiliary pull-up

Programmable I/O Pin Outs (50-Pin header)

Pin No	I/O Connector
1	Input#16
3	Input#15
5	Input#14
7	Input#13
9	Input#12
11	Input#11
13	Input#10
14	Input #9
17	Output #8
19	Output #7
21	Output #6
23	Output #5
25	Input #8
27	Input#7
29	Input#6
31	Input#5
33	Output#4
35	Output#3
37	Output#2
39	Output#1
41	Input#4
43	Input #3
45	Input#2
47	Input#1
49	+5 VDC

PDS/PDX Ministepping Systems**PDS/PDX Drives Motor connector (5-Pin screw)**

Pin No.	Signal
1	A+
2	A
3	GND
4	B+
5	B

**Stepper and Servo Driven Linear Actuators
ET Series****PDS/PDX Drives AC Power (IEC Plug)**

Pin No.	Signal
1	Hot (Line)
2	GND
3	Neutral

PDS Drive Switch Functions

Pin No.	Signal
1	Self-Test
2	Standby Mode
3	Oscillator Int/Ext Potentiometers
4	Step Resolution
5	Step Resolution
6	Motor Current
7	Motor Current
8	Motor Current

PDS Drive Control I/O Connector (25-Pin D socket)

Pin No.	Signal
1	Step +
2	Direction +
3	Reserved—Do Not Connect
4	Reserved—Do Not Connect
5	Reserved—Do Not Connect
6	External Slow Potentiometer
7	External Fast Potentiometer
8	Reserved—Do Not Connect
9	Fault +
10	Reserved—Do Not Connect
11	Reserved—Do Not Connect
12	Slow Run
13	Fast Run
14	Step -
15	Direction
16	Shutdown +
17	Shutdown -
18	Reserved—Do Not Connect
19	External Potentiometer Common
20	Internal Clock Out
21	Fault -
22	Reserved—Do Not Connect
23	Reserved—Do Not Connect
24	Reserved—Do Not Connect
25	GND

PDX Drive/Indexer Switch Functions

Pin No.	Signal
1	Self-Test
2	Standby Mode
3	No Function
4	Step Resolution
5	Step Resolution
6	Motor Current
7	Motor Current
8	Motor Current

Pinouts - Stepper Systems

PDX Drive/Indexer Control
I/O Connector (25-Pin D Socket)

Pin No.	Signal
1	Step Output
2	Direction Output
3	CW Limit
4	CCW Limit
5	Home Input
6	Reserved—Do Not Connect
7	GND
8	Output 2
9	Fault Output
10	Output 1
11	Sequence Select Input 1
12	Sequence Select Input 2
13	Sequence Select Input 3
14	TX-R5232C
15	RX-R5232C
16	Shutdown Output
17	Encoder Channel A
18	Encoder Channel B
19	Encoder Channel Z
20	Trigger Input 1
21	Trigger Input 2
22	Trigger Input 3

S Series
(S, SX & SXF Microstepping Systems)

S Drive

Indexer (standard 25-Pin D removable connector)

Pin No.	Signal
1	+Step
2	+ Direction
9	Fault output-collector
11	+ Zero phase
14	-Step
15	- Direction
16	+Shutdown
17	-Shutdown
21	Fault output-emitter
23	- Zero phase

Motor (9-Pin removable connector)

Pin No.	Signal
1	Interlock
2	A-CT
3	A +
4	A -
5	Gnd
6	B +
7	B -
8	B-CT
9	Interlock

SX and SXF Drive /Indexer

Motor Screw Terminal/Indexer (9-Pin removable connector)

Pin No.	Signal
1	Interlock
2	A-CT
3	A +
4	A -
5	GND
6	B +
7	B -
8	B-CT
9	Interlock

Encoder Screw Terminal (13-Pin removable connector)

Pin No.	Signal
1	+5v
2	GND
3	CHA+
4	CHA-
5	CHB+
6	CHB-
7	CHZ+
8	CHZ-
9	ACC
10	GNO
11	Shield
12	RSV+
13	RSV

Inputs/Outputs (24-Pin screw terminal)

Pin No.	Signal
1	Rx-RS232C
2	Tx-RS232C
3	GND—RS232C
4	+5V
5	Opto 1
6	CW limit
7	CCW limit
8	Home
9	Opto 2
10	Registration
11	Input 1
12	Input 2
13	Input 3
14	Input 4
15	Input 5
16	Input 6
17	Input 7
18	Input 8
19	Output 1
20	Output 2
21	Output 3
22	Output 4
23	Fault
24	GND

Stepper Motor Wiring Information

**Standard Motor
(Motor Codes 21, 31, and 41)**

The standard stepper motor is equipped with a cable grommet at the motor and a 3 meter (10 ft) cable. The opposite end of the cable includes a Phoenix® connector which mates directly to a ZETA4/ZETA6104 or S/SX drive or SX drive/indexer. PDS and PDX include 5 pin Phoenix® connector.

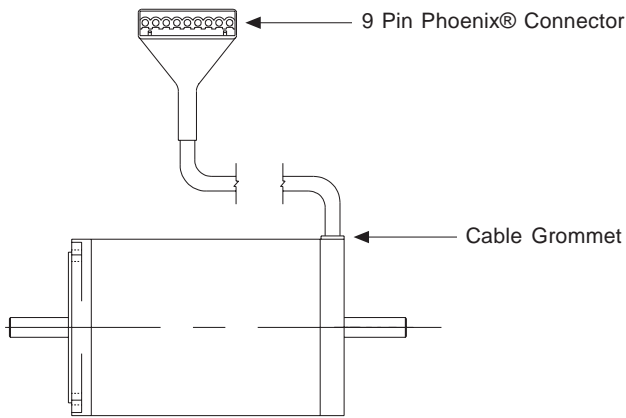

Wiring Diagrams:

**ZETA4/ZETA6104 + S/SX Motor wired in series
9 Pin Phoenix® Connector**

Motor Code 2* and 3*
(S57-102 and S83-135)

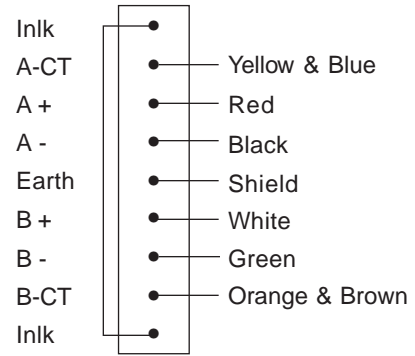

Motor Code 4*
(S106-178)

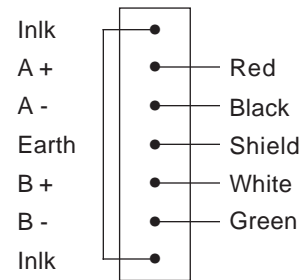

**PDS/PDX Motor wired in series ^
5 Pin Phoenix® Connector**

Motor Code 2*, 3*, and 4*
(S57-102, S83-135 and S106-178)

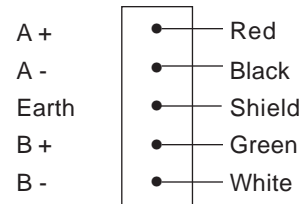

^ For motor code 2* and 3*: shunt yellow to blue and orange to brown.

**Conduit Connector
(Motor Codes 22, 32, and 42)**

For applications requiring additional wiring rigidity and protection, a conduit connector option can be specified. It allows for the installation of customer specific connectors. Wiring is cut short (approx. 2 in.) into flying leads from motor end cap. Color coding is identical to the standard motor option.

**Brad Harrison Connector
(Motor Codes 23, 33, and 43)**

Brad Harrison connectors feature quick disconnect to reduce downtime to a minimum for maximum performance and reliability in high-speed operations. Molded connectors provide a positive seal against moisture and contaminants. Contacts are keyed to avoid mismatching for fast, sure connection.

**Wiring Diagrams for Brad Harrison
Connector (Motor Codes 23, 33, and 43)**

ZETA4/ZETA6104 or S/SX Motor
wired in series
9 Pin Phoenix® Connector*

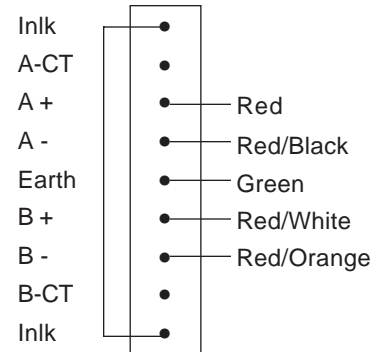

PDS Drive, PDX Drive/Indexer Motor
wired in series
5 Pin Phoenix® Connector



Mating Cable supplied with connector option, Cable length 3.7 meters (12 ft); includes mating Brad Harrison connector one end, and nine, seven, or five pin Phoenix® connector at other end.

* Motor Code 4* (S106-178) includes 7 pin Phoenix® Connector. Connector is wired the same as 9 pin version, however without A-CT or B-CT.

Hall Effect sensors provide the following features:

- NO (Normally Open) or NC (Normally Closed)
- Fully adjustable travel
- Solid state electronics
- LED Indicator
- 5-24VDC
- PNP and NPN Available
- Senses magnet on screw carrier
- Medium cost
- Long life

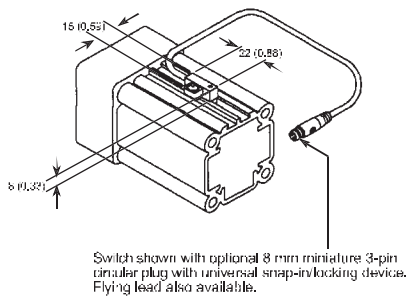

Two types of Hall effect sensors are available for use with the Electro-Thrust cylinder. The normally open sensor is typically used for mid-position sensing, such as homing applications. The normally closed sensor is generally used to indicate over-travel at the end of the stroke, and is used in a safety circuit to prevent damage to components caused by over-travel.

Hall Effect Sensor Information				
Part No.	Type	LED Color	Logic	Cable/Connector
SMH-1P	N.O.	Green	PNP	1.5m Black with Leads
SMH-1N	N.O.	Red	NPN	1.5m Black with Leads
SMC-1P	N.C.	Yellow	PNP	1.5m Black with Leads
SMC-1N	N.C.	White/Red	NPN	1.5m Black with Leads
SMH-1PC	N.O.	Green	PNP	150mm Black with Connector
SMH-1NC	N.O.	Red	NPN	150mm Black with Connector
SMC-1PC	N.C.	Yellow	PNP	150mm Black with Connector
SMC-1NC	N.C.	White/Red	NPN	150mm Black with Connector

Note

- End of travel sensors do not reduce available stroke.
- When using Hall Effect sensors, BLHX controls use PNP sensors for Home and End-of-Travels. SX, ZETA, PDX, and APEX 6152(4) controls use NPN sensors for Home and End-of-Travel.
- PDX requires external +5VDC power supply for Hall Effect Sensors.

HALL EFFECT SPECIFICATIONS

Type	Solid State Type (PNP or NPN)
Switching Logic	N.O. (Normally Open) or N.C. (Normally Closed)
Supply voltage Range	5-24VDC
Max. Switch Current	150 mA
Current Consumption:	7mA at 12VDC, 14mA at 24VDC
Switching Response:	500Hz Maximum
Residual Voltage:	0.8 V Maximum (150 mA)
Leakage Current	10µA Maximum
Insulation Resistance	100 M Ohm Minimum
Min. Current for LED:	1 mA
Operating Temperature:	-10° to 85°C (14° to 185°)**
Lead Termination	1500 mm (60 in) or 150 mm (6 in) with connector
Industrial Protection:	IP67
Shock Resistance:	50 G's. 490 m/sec ²

PNP

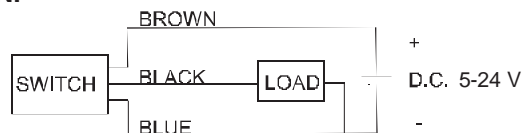

NPN

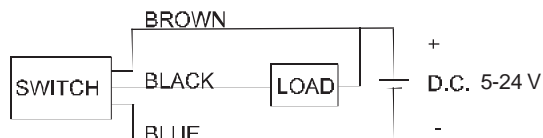

Reed Switch Sensors

Note: Use of a protection circuit is recommended when connecting an inductive load (for example, connecting a relay or an electromagnetic valve, etc.).

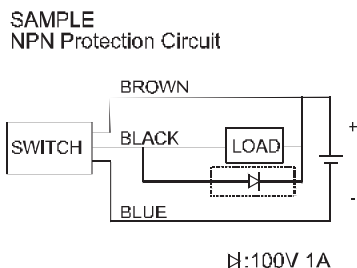

REED SWITCH SENSORS

(Not compatible with TTL level logic.)

Reed switches provide the following features:

- NO (Normally Open) or NC (Normally Closed)
- Fully adjustable travel
- Mechanical reed
- LED Indicator
- 5-24VDC or 85-150VAC¹
- Low Amp. and High Amp.
- Senses magnet on screw carrier
- Lowest cost
- Medium life

Reed switches are available in a normally open or closed configuration. The low amp switch is suitable for connection to PLCs or other low current devices. The high amp switch can be used to drive sequences, relays, coils, or other devices directly. Not compatible with TTL level logic.

¹ Polarity is restricted or DC operation (+) to Brown, (-) to Blue. If reversed (for TTL level compatibility), contacts will close but LED will not illuminate.

Integral circuit for switching contact protection (Inductive Loads)

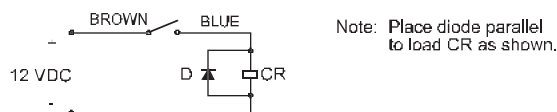

D: Diode -- select a diode with the breakdown voltage and current according to the load.
CR: Relay coil (under 0.5 W coil rating).

Recommended circuit for longer switch life (125VAC) (Inductive Loads)

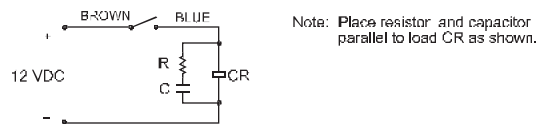

D: Diode -- select a diode with the breakdown voltage and current according to the load.
CR: Relay coil (under 0.5 W coil rating).

REED SWITCH INFORMATION

Part No.	Type	LED Color	Rating	Cable/connector
SMR-1	N.O.	Green	Hi Amp	1.5 m Gray with Leads
SMR-1L	NO.	Red	Low Amp	1.5 m Gray with Leads
SMD-1L	N.C.	Yellow	Low Amp	1.5 m Gray with Leads
SMR-1C	N.O.	Green	Hi Amp	150 mm Gray with connector
SMR-1LC	N.O.	Red	Low Amp	150 mm Gray with Connector
SMD-1LC	N.C.	Yellow	Low Amp	150 mm Gray with Connector

Reed Switch Specifications**MODELS SMR-1L, SMD-1L LOW AMP REED SWITCH SPECIFICATIONS**

Switching Logic:	Normally Open (SMR-1 L) Normally Closed (SMD-1 L)
Voltage Rating:	85-125 VAC (N.O.) 5-24 VAC (N.C.) 5-24 VDC* (N.O.) 5-24 VDC* (N.C.)
Power Rating:	AC or DC Resistive Load: 10 watts (N.O.) AC or DC Inductive Load: 5 watts (N.O.) AC or DC: 3 watts (N.C.)
Switching Current Range:	Resistive Load (PC, Sequencer): 5-40 mA (N.O.), 5-25 mA (N.C.) Inductive Load (Relay): 5-25 mA
Minimum Current for LED:	5mA
Switching Response:	300 Hz (N.O.), 200 Hz (N.C.)
Breakdown Voltage:	200VDC
Contact Resistance:	100M Ohm minimum.
Operating Temperature:	-10 ^o to 85 ^o C (14 ^o to 185 ^o)**
Lead Termination:	1500 mm (60 In) or 150 mm (6 in) with connector
Industrial Protection:	IP67
Shock Resistance:	30 g's, 300 m/sec ²

*Polarity restriction for DC operation: (+) to brown *and* (-) to blue.

**Exceeds temperature range for ET series mechanical components

NOTE: Use care not to exceed the switch's power rating while operating within the switch's voltage and current limits.

MODELS SMR-1 HIGH AMP SWITCH SPECIFICATIONS

Switching Logic:	Normally Open
Voltage Rating:	85-125 VAC 5-24 VDC*
Power Rating:	AC or DC Resistive Load: 10 watts AC or DC Inductive Load: 5 watts
Switching Current Range:	Resistive Load (PC, Sequencer): 30-300 mA Inductive Load (Relay): 30-100 mA
Minimum Current for LED:	18 mA
Switching Response:	300 Hz
Breakdown Voltage:	200VDC
Contact Resistance:	100M Ohm minimum
Operating Temperature:	-10 ^o to 85 ^o C (14 ^o to 185 ^o)**
Lead Termination:	1500 mm (60 in.) or 150 mm (6 in.) with connector
Industrial Protection:	IP67
Shock Resistance:	30 g's, 300 m/sec ²

*Polarity restriction for DC operation: (+) to brown *and* (-) to blue.

**Exceeds temperature range for ET series mechanical components

Quick Connect and Brake Option

Quick Connect Option for Switches/Sensors

An optional connector is available for all styles of switches. The male plug can be a snap-in or a threaded type connector. The following table provides part numbers for a mating 5 m (16 ft) polyurethane covered cable connector. The manufacturers are listed for your convenience.

Note: Hall Effect sensors use all three wires while Reed switches will only use the brown and blue wires.

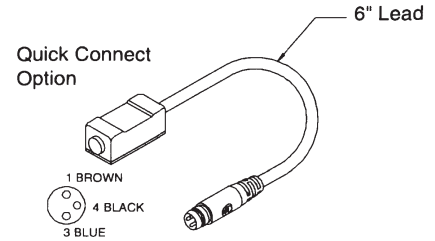

Manufacturer	Snap-in connector	Threaded connector
Parker	B8785	B8786
Brad Harrison	45300-102	45310-102
Lumberg	RKM3-61/5M	RKMV3-61/5m
Hirschmann	ELKA-K308PUR014	N.A.

Wiring Information

Brake Option

The brake option (only available on ET Series size 50, 80, and 100) prevents back driving of the cylinder rod when power is removed from the motor. The spring loaded, friction disk-type brake requires a separate power supply (24 VDC or 115 VAC) provided to the solenoid. This power keeps the brake disengaged allowing motion. When this power is removed (when the unit is at rest or during a power failure), the brake engages preventing back-driving. The brake mounts directly to the rear of the screw. For servo systems, the brake option is only available in the parallel mounting configuration. For stepper systems, the brake may also be applied to the rear shaft of the motor. Refer to ordering information (p. 7) for coding of options.

Consult factory for details concerning this option.

Flying lead: _____

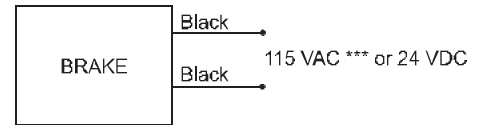

Connector version: _____

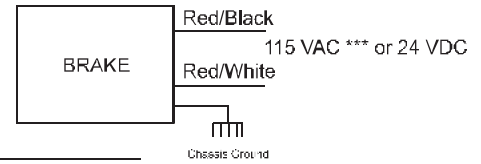

*** 115 VAC is internally rectified.

	ET50	ET80	ET100
Voltage	24 VDC or 115 VAC		
Current	24 VDC: 0.542A 115 VAC: 0.113A	24 VDC: 0.667A 115 VAC: 0.139A	24 VDC: 1.042A 115 VAC: 0.217A
Holding torque	3.36 Nm (30 lb-in)	11.2 Nm (100 lb-in)	22.4 NM (200 lb-in)