



Parker Hannifin Corporation
Automation Actuator Division
135 Quadral Drive
Wadsworth, Ohio 44281
Telephone (330) 336-3511
Facsimile (330) 334-3335

ERV-SPLICE ASSEMBLY
Assembly Instructions
Issued: August 15, 2002

ERV SPLICE ASSEMBLY INSTRUCTIONS

Step 1

Insert the rib plates into the first piece of the body with the raised side of the plate against the inside of the body. See photo below. Loosely tighten the SHCS rib bolts.

Step 2

Insert the t-nuts into the slots on the body and assemble the side plates and bottom plate with the SHCS's as shown below.

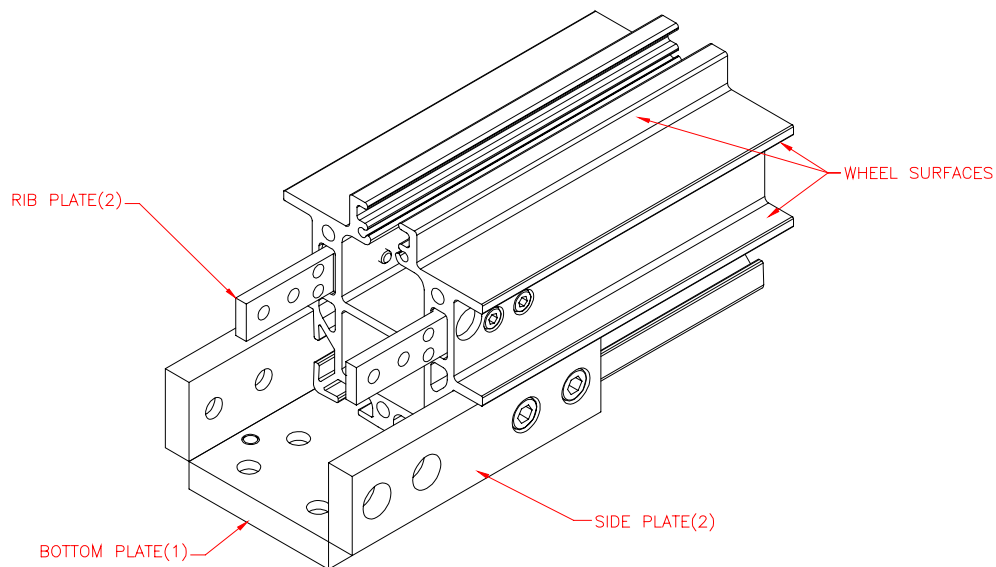

Step 3

Slide in the second piece of the body and loosely attach the SHCS's for the bottom plate, the side plates, and rib plates.

Step 4

Then go back and tighten the SHCS's on the first section of body on all the plates.



Parker Hannifin Corporation
Automation Actuator Division
135 Quadral Drive
Wadsworth, Ohio 44281
Telephone (330) 336-3511
Facsimile (330) 334-3335

ERV-SPLICE ASSEMBLY
Assembly Instructions
Issued: August 15, 2002

Step 5

Insert the bolts into the rib plate and adjust them until the top wheel surfaces (shown below) are flush.

Step 6

Adjust the set screws in the bottom plate until the side wheel surfaces (shown by arrow below) are flush.

Repeat steps 5 and 6 as needed to obtain a smooth transition surface.

Step 7

Lastly, tighten all the bolts attaching the three plates to the second piece of the body. Tighten the plates in the following order: rib, bottom, and sides.

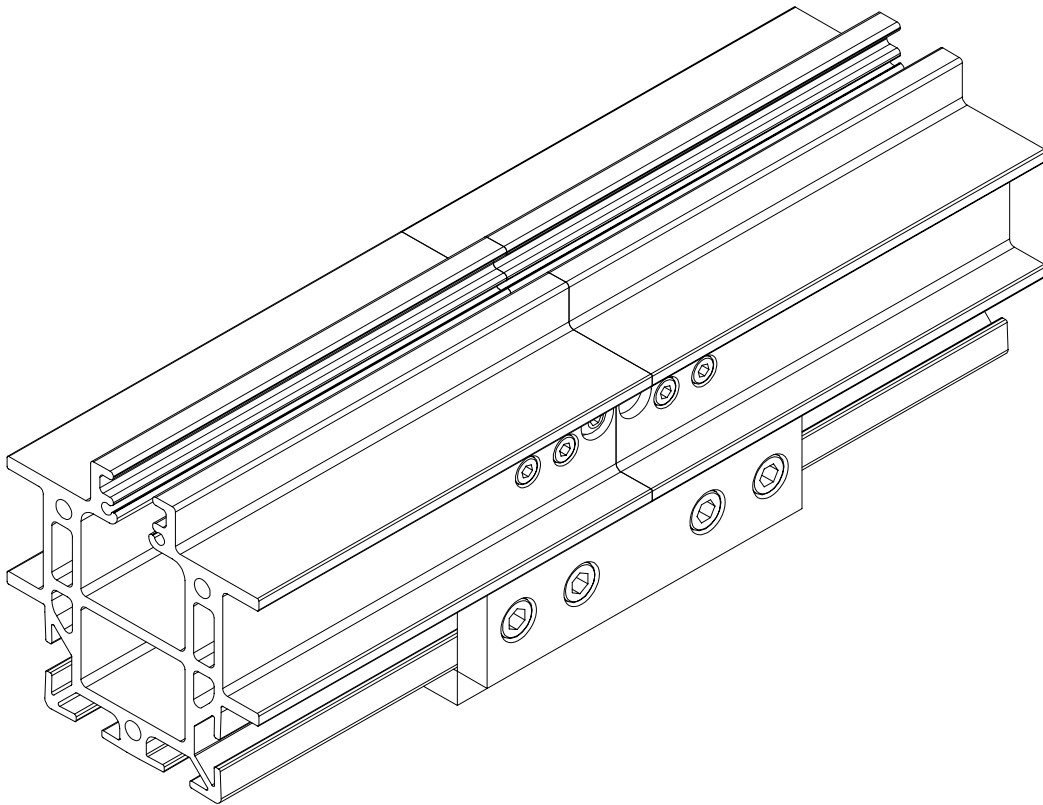



Parker Hannifin Corporation
Automation Actuator Division
 135 Quadral Drive
 Wadsworth, Ohio 44281
 Telephone (330) 336-3511
 Facsimile (330) 334-3335

ERV-SPLICE ASSEMBLY
Assembly Instructions
Issued: August 15, 2002

Parts List

	Rib plate - ERVXXSPC03 (2)		Bottom plate - ERVXXSPC01 (1)		Side plates - ERVXXSPC02 (2)	
	Mounting screws	Adjustment screws	Mounting screws	Adjustment screws	Mounting screws	Adjustment screws
ERV56	CS-CM4X0.7-008	CS-CM5X0.8-006	CS-CM6X1.0-010	ESF3606	CS-CM6X1.0-010	ESF3606
ERV80	CS-CM6X1.0-012	CS-CM6X1.0-012	CS-CM8X1.25-016	ESF3208	CS-CM8X1.25-016	ESF3208
Quantity	8	2	8	8	8	8



Parker Hannifin Corporation
Automation Actuator Division
135 Quadral Drive
Wadsworth, Ohio 44281
Telephone (330) 336-3511
Facsimile (330) 334-3335

ERV-SPLICE ASSEMBLY
Assembly Instructions
Issued: August 15, 2002