

MOTOR DATA @ 230 VAC SINE

MOTOR PARAMETERS	UNITS	VALUE
HORSEPOWER	HP RATED	1.05
KILOWATTS	KW RATED	0.78
MAX. OPERATING SPEED	N MAX RPM	3000
SPEED @ RATED TORQUE	N RATED RPM	2400
* CONTINUOUS RATED TORQUE @ 2400 RPM	N-LBS[Nm]	27.5[3.11]
* CONTINUOUS STALL TORQUE	N-LBS[Nm]	30.0[3.39]
CONTINUOUS LINE CURRENT	AMPS[RMS/φ]	2.6
PEAK TORQUE	AMP[S/RMS/φ]	111.5[12.6]
PEAK CURRENT	AMP[S/RMS/φ]	9.6
MAX. THEORETICAL ACCEL.	RAD/SEC ²	112.513
TORQUE SENSITIVITY	Kt N-LBS/AMPS/φ[Nm/AMPS/φ]	11.6[1.31]
BACK EMF (LINE TO LINE)	Vrms/Krpm	73.0
D.C. RESISTANCE (P-P)	OHMS	8.4
INDUCTANCE (P-P)	MILLIHENRIES	27
ROTOR INERTIA	Jm [N-LBS-SEC ²] [Kg-M ²]	.000991[.000116]
STATIC FRICTION	Tf [N-LBS] [Nm]	0.5[.06]

*25°C AMBIENT WITH A MAXIMUM CASE TEMPERATURE OF 100°C ON MOTOR. MOTOR MOUNTED ON A 10" X 10" X 1/4" ALUMINUM HEATSINK. THERMOSTAT IN STATOR WINDINGS WILL OPEN IF WINDING TEMPERATURE EXCEEDS 155°C. THIS ALLOWS FOR AN APPROXIMATE +10% HEADROOM IN THE CONTINUOUS TORQUE RATING BEFORE THERMOSTAT OPENS.

MECHANICAL NOTES:

1. AXIAL LOAD: 25 LBS MAX
2. RADIAL LOAD: 40 LBS MAX @ 1" FROM FACE
3. MOTOR SEALED TO IP65.
4. MOTOR WEIGHT: 9.8 LBS [4.5 Kg]
5. MOTOR FINISH: BLACK EPOXY
6. MOTOR OUTPUT SHAFT: STAINLESS STEEL
7. MILLIMETERS (INCHES)

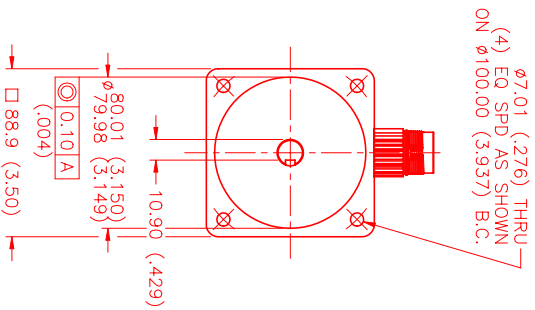

CONNECTION CHART

MOTOR/THERM CONNECTOR:
 @BEGA089NN0000007000
 (270-00256)

RESOLVER CONNECTOR:
 @AEGA052NN00000020000
 (270-00257)

PIN	WIRE FUNCTION	WIRE COLOR
1	φR(U1)	RED
2	PE GND	GRN/YEL
3	φT(W1)	BLUE
4	φS(V1)	BLACK
A	-	-
B	-	-
C	THERM	BLACK
D	THERM	BLACK

PIN	WIRE FUNCTION	WIRE COLOR
1	-	-
2	REF(R1)	RED/WHT
3	REF GND(R2)	YEL/WHT
4	COS GND(S1)	BLACK
5	COS(S3)	RED
6	SIN(S2)	YELLOW
7	SIN GND(S4)	BLUE
8	-	-
9	-	-
10	-	-
11	-	-
12	-	-

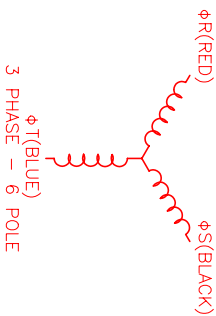
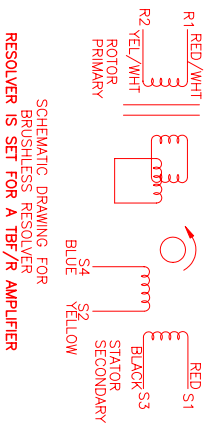
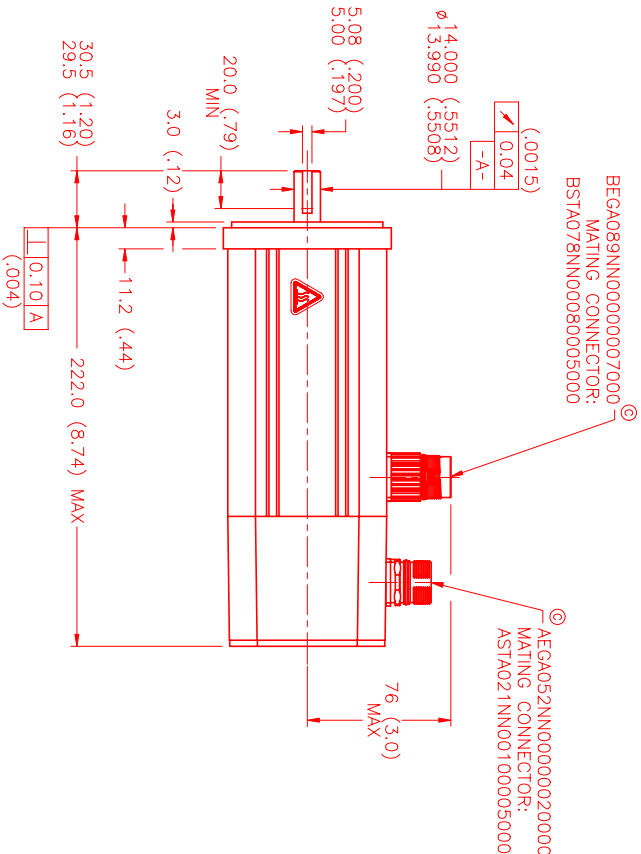

REV.	DESCRIPTION	DATE	APPD.
A	PRELIMINARY	11/24/98	MWS
B	E.C.O. - 547	11/3/99	MWS
C	E.C.O. - 572	5/25/00	AJS
	E.C.O. - 620	4/10/01	AJS

NO.	PART NUMBER	DESCRIPTION	QTY.
1	MWS	MWS Systems Corporation Automation Division	
2	MWS	MWS Systems Corporation Automation Division	
3	MWS	MWS Systems Corporation Automation Division	
4	MWS	MWS Systems Corporation Automation Division	
5	MWS	MWS Systems Corporation Automation Division	
6	MWS	MWS Systems Corporation Automation Division	
7	MWS	MWS Systems Corporation Automation Division	
8	MWS	MWS Systems Corporation Automation Division	
9	MWS	MWS Systems Corporation Automation Division	
10	MWS	MWS Systems Corporation Automation Division	
11	MWS	MWS Systems Corporation Automation Division	
12	MWS	MWS Systems Corporation Automation Division	
13	MWS	MWS Systems Corporation Automation Division	
14	MWS	MWS Systems Corporation Automation Division	
15	MWS	MWS Systems Corporation Automation Division	
16	MWS	MWS Systems Corporation Automation Division	
17	MWS	MWS Systems Corporation Automation Division	
18	MWS	MWS Systems Corporation Automation Division	
19	MWS	MWS Systems Corporation Automation Division	
20	MWS	MWS Systems Corporation Automation Division	
21	MWS	MWS Systems Corporation Automation Division	
22	MWS	MWS Systems Corporation Automation Division	
23	MWS	MWS Systems Corporation Automation Division	
24	MWS	MWS Systems Corporation Automation Division	
25	MWS	MWS Systems Corporation Automation Division	
26	MWS	MWS Systems Corporation Automation Division	
27	MWS	MWS Systems Corporation Automation Division	
28	MWS	MWS Systems Corporation Automation Division	
29	MWS	MWS Systems Corporation Automation Division	
30	MWS	MWS Systems Corporation Automation Division	
31	MWS	MWS Systems Corporation Automation Division	
32	MWS	MWS Systems Corporation Automation Division	
33	MWS	MWS Systems Corporation Automation Division	
34	MWS	MWS Systems Corporation Automation Division	
35	MWS	MWS Systems Corporation Automation Division	
36	MWS	MWS Systems Corporation Automation Division	
37	MWS	MWS Systems Corporation Automation Division	
38	MWS	MWS Systems Corporation Automation Division	
39	MWS	MWS Systems Corporation Automation Division	
40	MWS	MWS Systems Corporation Automation Division	
41	MWS	MWS Systems Corporation Automation Division	
42	MWS	MWS Systems Corporation Automation Division	
43	MWS	MWS Systems Corporation Automation Division	
44	MWS	MWS Systems Corporation Automation Division	
45	MWS	MWS Systems Corporation Automation Division	
46	MWS	MWS Systems Corporation Automation Division	
47	MWS	MWS Systems Corporation Automation Division	
48	MWS	MWS Systems Corporation Automation Division	
49	MWS	MWS Systems Corporation Automation Division	
50	MWS	MWS Systems Corporation Automation Division	
51	MWS	MWS Systems Corporation Automation Division	
52	MWS	MWS Systems Corporation Automation Division	
53	MWS	MWS Systems Corporation Automation Division	
54	MWS	MWS Systems Corporation Automation Division	
55	MWS	MWS Systems Corporation Automation Division	
56	MWS	MWS Systems Corporation Automation Division	
57	MWS	MWS Systems Corporation Automation Division	
58	MWS	MWS Systems Corporation Automation Division	
59	MWS	MWS Systems Corporation Automation Division	
60	MWS	MWS Systems Corporation Automation Division	
61	MWS	MWS Systems Corporation Automation Division	
62	MWS	MWS Systems Corporation Automation Division	
63	MWS	MWS Systems Corporation Automation Division	
64	MWS	MWS Systems Corporation Automation Division	
65	MWS	MWS Systems Corporation Automation Division	
66	MWS	MWS Systems Corporation Automation Division	
67	MWS	MWS Systems Corporation Automation Division	
68	MWS	MWS Systems Corporation Automation Division	
69	MWS	MWS Systems Corporation Automation Division	
70	MWS	MWS Systems Corporation Automation Division	
71	MWS	MWS Systems Corporation Automation Division	
72	MWS	MWS Systems Corporation Automation Division	
73	MWS	MWS Systems Corporation Automation Division	
74	MWS	MWS Systems Corporation Automation Division	
75	MWS	MWS Systems Corporation Automation Division	
76	MWS	MWS Systems Corporation Automation Division	
77	MWS	MWS Systems Corporation Automation Division	
78	MWS	MWS Systems Corporation Automation Division	
79	MWS	MWS Systems Corporation Automation Division	
80	MWS	MWS Systems Corporation Automation Division	
81	MWS	MWS Systems Corporation Automation Division	
82	MWS	MWS Systems Corporation Automation Division	
83	MWS	MWS Systems Corporation Automation Division	
84	MWS	MWS Systems Corporation Automation Division	
85	MWS	MWS Systems Corporation Automation Division	
86	MWS	MWS Systems Corporation Automation Division	
87	MWS	MWS Systems Corporation Automation Division	
88	MWS	MWS Systems Corporation Automation Division	
89	MWS	MWS Systems Corporation Automation Division	
90	MWS	MWS Systems Corporation Automation Division	
91	MWS	MWS Systems Corporation Automation Division	
92	MWS	MWS Systems Corporation Automation Division	
93	MWS	MWS Systems Corporation Automation Division	
94	MWS	MWS Systems Corporation Automation Division	
95	MWS	MWS Systems Corporation Automation Division	
96	MWS	MWS Systems Corporation Automation Division	
97	MWS	MWS Systems Corporation Automation Division	
98	MWS	MWS Systems Corporation Automation Division	
99	MWS	MWS Systems Corporation Automation Division	
100	MWS	MWS Systems Corporation Automation Division	