

MOTOR DATA @ 54 VAC (TRAP)

MOTOR PARAMETERS	UNITS	VALUE
HORSEPOWER	HP	0.18
KILOWATTS	KW	0.13
MAX. OPERATING SPEED	N. MAX RPM	3400
SPEED @ RATED TORQUE	N RATED RPM	2100
* CONTINUOUS RATED TORQUE @ 2100 RPM	IN-LBS[Nm]	5.3[0.60]
* CONTINUOUS STALL TORQUE	IN-LBS[Nm]	5.8[0.66]
CONTINUOUS LINE CURRENT	AMPS	3.9
PEAK TORQUE	IN-LBS[Nm]	17.0[2.0]
PEAK CURRENT	AMPS	11.6
MAX. THEORETICAL ACCEL.	RAD/SEC ²	77,273
TORQUE SENSITIVITY	Kt IN-LBS/AMP[Nm/AMP]	1.51[0.171]
BACK EMF (LINE TO LINE)	Vrms/Krpm	13.4
D.C. RESISTANCE (P-P)	OHMS	3.1
INDUCTANCE (P-P)	MILLIHENRIES	4.9
ROTOR INERTIA W/BRAKE	Jm [IN-LBS-SEC ²][Kg-M ²]	0.00022[0.00025]
STATIC FRICTION	Tf [IN-LBS][Nm]	0.6[0.07]

*25°C AMBIENT WITH A MAXIMUM CASE TEMPERATURE OF 85°C ON MOTOR. MOTOR MOUNTED ON A 1/2" X 1/2" X 1/2" ALUMINUM HEAT SINK. THERMOSTAT IN STATOR WINDINGS WILL OPEN IF WINDING TEMPERATURE EXCEEDS 155°C. THIS ALLOWS FOR AN APPROXIMATE +10% HEADROOM IN THE CONTINUOUS TORQUE RATING BEFORE THERMOSTAT OPENS.

MECHANICAL NOTES:

- AXIAL LOAD: 20 LBS. MAX
- RADIAL LOAD: 35 LBS. MAX @ 1" FROM FACE
- MOTOR SEALED TO IP65.
- MOTOR WEIGHT: 4.4 LBS. [2.0 Kg]
- MOTOR FINISH: BLACK EPOXY
- MOTOR OUTPUT SHAFT: STAINLESS STEEL
- MILLIMETERS (INCHES)
- THIS MOTOR'S OUTPUT KEY IS A PRESS FIT.

FAILSAFE BRAKE:

MIN. HOLDING TORQUE: 24 IN-LBS
INPUT VOLTAGE: 24 VOLTS

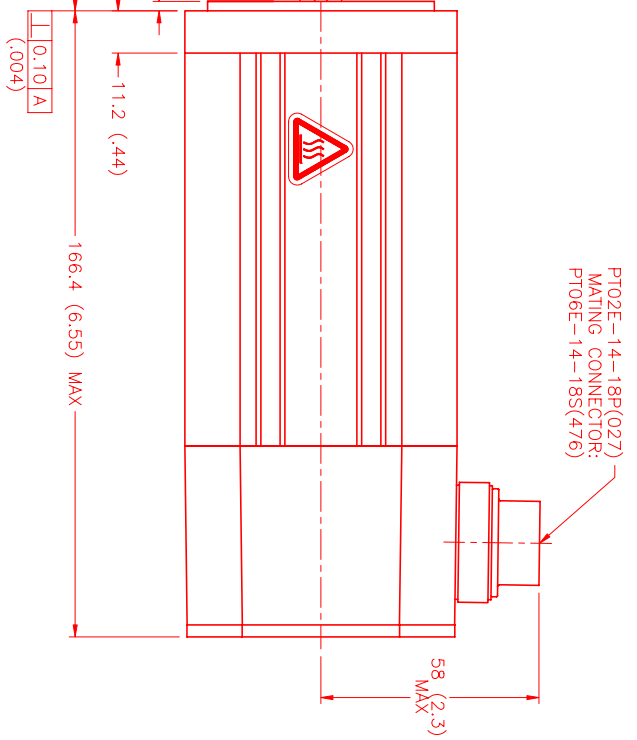
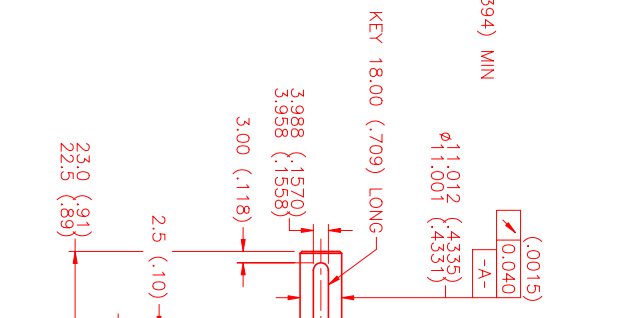
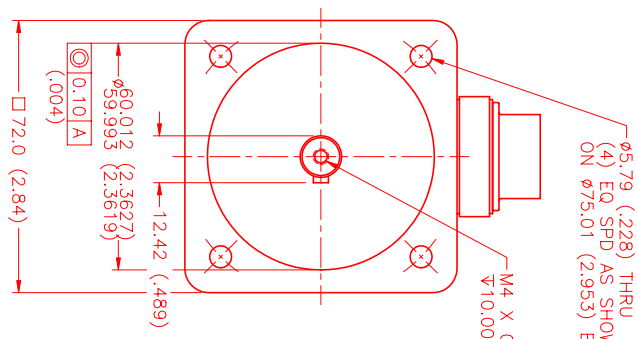

CONNECTION CHART MOTOR/THERM/RES/BRK CONNECTOR: PT02E-14-18P(027) (270-00024)

MTR/RES/THERM	WIRE	WIRE LEADS
PIN	FUNCTION	WIRE COLOR
A	ΦR	RED
B	ΦS	BLACK
C	ΦT	BLUE
D	PE GND	GRN/YEL
U	THERM	BLACK
N	THERM	BLACK
H	SIN	YELLOW
G	COS GND	BLACK
S	COS	RED
F	SIN GND	BLUE
R	REF GND	YEL/WHI
E	REF	RED/WHI
J	RES SHLD	GRN/YEL
K	BRK (+)	□ IN4007
L	BRK (-)	□ IN4007
M	BRK SHLD	-
P	-	-
T	-	-

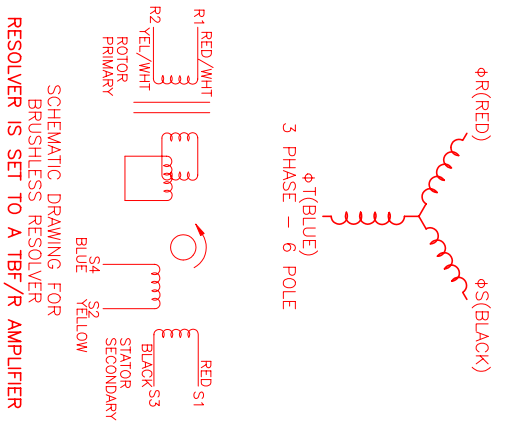

REV.	DESCRIPTION	DATE	APP'D.
PRELIMINARY		7/13/01	LIN

NO.	PART NUMBER	DESCRIPTION	QTY.
1	PT02E-14-18P(027)	MATING CONNECTOR	1
2	PT06E-14-18S(476)	MATING CONNECTOR	1

NO.	PART NUMBER	DESCRIPTION	QTY.
1	PT02E-14-18P(027)	MATING CONNECTOR	1
2	PT06E-14-18S(476)	MATING CONNECTOR	1

NO.	PART NUMBER	DESCRIPTION	QTY.
1	PT02E-14-18P(027)	MATING CONNECTOR	1
2	PT06E-14-18S(476)	MATING CONNECTOR	1

NO.	PART NUMBER	DESCRIPTION	QTY.
1	PT02E-14-18P(027)	MATING CONNECTOR	1
2	PT06E-14-18S(476)	MATING CONNECTOR	1

NO.	PART NUMBER	DESCRIPTION	QTY.
1	PT02E-14-18P(027)	MATING CONNECTOR	1
2	PT06E-14-18S(476)	MATING CONNECTOR	1

NO.	PART NUMBER	DESCRIPTION	QTY.
1	PT02E-14-18P(027)	MATING CONNECTOR	1
2	PT06E-14-18S(476)	MATING CONNECTOR	1

NO.	PART NUMBER	DESCRIPTION	QTY.
1	PT02E-14-18P(027)	MATING CONNECTOR	1
2	PT06E-14-18S(476)	MATING CONNECTOR	1

NO.	PART NUMBER	DESCRIPTION	QTY.
1	PT02E-14-18P(027)	MATING CONNECTOR	1
2	PT06E-14-18S(476)	MATING CONNECTOR	1

NO.	PART NUMBER	DESCRIPTION	QTY.
1	PT02E-14-18P(027)	MATING CONNECTOR	1
2	PT06E-14-18S(476)	MATING CONNECTOR	1

NO.	PART NUMBER	DESCRIPTION	QTY.
1	PT02E-14-18P(027)	MATING CONNECTOR	1
2	PT06E-14-18S(476)	MATING CONNECTOR	1

NO.	PART NUMBER	DESCRIPTION	QTY.
1	PT02E-14-18P(027)	MATING CONNECTOR	1
2	PT06E-14-18S(476)	MATING CONNECTOR	1

NO.	PART NUMBER	DESCRIPTION	QTY.
1	PT02E-14-18P(027)	MATING CONNECTOR	1
2	PT06E-14-18S(476)	MATING CONNECTOR	1

NO.	PART NUMBER	DESCRIPTION	QTY.
1	PT02E-14-18P(027)	MATING CONNECTOR	1
2	PT06E-14-18S(476)	MATING CONNECTOR	1

NO.	PART NUMBER	DESCRIPTION	QTY.
1	PT02E-14-18P(027)	MATING CONNECTOR	1
2	PT06E-14-18S(476)	MATING CONNECTOR	1

NO.	PART NUMBER	DESCRIPTION	QTY.
1	PT02E-14-18P(027)	MATING CONNECTOR	1
2	PT06E-14-18S(476)	MATING CONNECTOR	1

NO.	PART NUMBER	DESCRIPTION	QTY.
1	PT02E-14-18P(027)	MATING CONNECTOR	1
2	PT06E-14-18S(476)	MATING CONNECTOR	1

NO.	PART NUMBER	DESCRIPTION	QTY.
1	PT02E-14-18P(027)	MATING CONNECTOR	1
2	PT06E-14-18S(476)	MATING CONNECTOR	1

NO.	PART NUMBER	DESCRIPTION	QTY.
1	PT02E-14-18P(027)	MATING CONNECTOR	1
2	PT06E-14-18S(476)	MATING CONNECTOR	1

NO.	PART NUMBER	DESCRIPTION	QTY.
1	PT02E-14-18P(027)	MATING CONNECTOR	1
2	PT06E-14-18S(476)	MATING CONNECTOR	1

NO.	PART NUMBER	DESCRIPTION	QTY.
1	PT02E-14-18P(027)	MATING CONNECTOR	1
2	PT06E-14-18S(476)	MATING CONNECTOR	1

NO.	PART NUMBER	DESCRIPTION	QTY.
1	PT02E-14-18P(027)	MATING CONNECTOR	1
2	PT06E-14-18S(476)	MATING CONNECTOR	1

NO.	PART NUMBER	DESCRIPTION	QTY.
1	PT02E-14-18P(027)	MATING CONNECTOR	1
2	PT06E-14-18S(476)	MATING CONNECTOR	1

NO.	PART NUMBER	DESCRIPTION	QTY.
1	PT02E-14-18P(027)	MATING CONNECTOR	1
2	PT06E-14-18S(476)	MATING CONNECTOR	1

NO.	PART NUMBER	DESCRIPTION	QTY.
1	PT02E-14-18P(027)	MATING CONNECTOR	1
2	PT06E-14-18S(476)	MATING CONNECTOR	1

NO.	PART NUMBER	DESCRIPTION	QTY.
1	PT02E-14-18P(027)	MATING CONNECTOR	1
2	PT06E-14-18S(476)	MATING CONNECTOR	1

NO.	PART NUMBER	DESCRIPTION	QTY.
1	PT02E-14-18P(027)	MATING CONNECTOR	1
2	PT06E-14-18S(476)	MATING CONNECTOR	1

NO.	PART NUMBER	DESCRIPTION	QTY.
1	PT02E-14-18P(027)	MATING CONNECTOR	1
2	PT06E-14-18S(476)	MATING CONNECTOR	1

NO.	PART NUMBER	DESCRIPTION	QTY.
1	PT02E-14-18P(027)	MATING CONNECTOR	1
2	PT06E-14-18S(476)	MATING CONNECTOR	1

NO.	PART NUMBER	DESCRIPTION	QTY.
1	PT02E-14-18P(027)	MATING CONNECTOR	1
2	PT06E-14-18S(476)	MATING CONNECTOR	1

NO.	PART NUMBER	DESCRIPTION	QTY.
1	PT02E-14-18P(027)	MATING CONNECTOR	1
2	PT06E-14-18S(476)	MATING CONNECTOR	1

NO.	PART NUMBER	DESCRIPTION	QTY.
1	PT02E-14-18P(027)	MATING CONNECTOR	1
2	PT06E-14-18S(476)	MATING CONNECTOR	1

NO.	PART NUMBER	DESCRIPTION	QTY.
1	PT02E-14-18P(027)	MATING CONNECTOR	1
2	PT06E-14-18S(476)	MATING CONNECTOR	1

NO.	PART NUMBER	DESCRIPTION	QTY.
1	PT02E-14-18P(027)	MATING CONNECTOR	1
2	PT06E-14-18S(476)	MATING CONNECTOR	1

NO.	PART NUMBER	DESCRIPTION	QTY.
1	PT02E-14-18P(027)	MATING CONNECTOR	1
2	PT06E-14-18S(476)	MATING CONNECTOR	1

NO.	PART NUMBER	DESCRIPTION	QTY.
1	PT02E-14-18P(027)	MATING CONNECTOR	1
2	PT06E-14-18S(476)	MATING CONNECTOR	1

NO.	PART NUMBER	DESCRIPTION	QTY.
1	PT02E-14-18P(027)	MATING CONNECTOR	1
2	PT06E-14-18S(476)	MATING CONNECTOR	1

NO.	PART NUMBER	DESCRIPTION	QTY.
1	PT02E-14-18P(027)	MATING CONNECTOR	1
2	PT06E-14-18S(476)	MATING CONNECTOR	1

NO.	PART NUMBER	DESCRIPTION	QTY.
1	PT02E-14-18P(027)	MATING CONNECTOR	1
2	PT06E-14-18S(476)	MATING CONNECTOR	1

NO.	PART NUMBER	DESCRIPTION	QTY.
1	PT02E-14-18P(027)	MATING CONNECTOR	1
2	PT06E-14-18S(476)	MATING CONNECTOR	1

NO.	PART NUMBER	DESCRIPTION	QTY.
1	PT02E-14-18P(027)	MATING CONNECTOR	1
2	PT06E-14-18S(476)	MATING CONNECTOR	1

NO.	PART NUMBER	DESCRIPTION	QTY.
1	PT02E-14-18P(027)	MATING CONNECTOR	1
2	PT06E-14-18S(476)	MATING CONNECTOR	1

NO.	PART NUMBER	DESCRIPTION	QTY.
1	PT02E-14-18P(027)	MATING CONNECTOR	1
2	PT06E-14-18S(476)	MATING CONNECTOR	1

NO.	PART NUMBER	DESCRIPTION	QTY.
1	PT02E-14-18P(027)	MATING CONNECTOR	1
2	PT06E-14-18S(476)	MATING CONNECTOR	1

NO.	PART NUMBER	DESCRIPTION	QTY.
1	PT02E-14-18P(027)	MATING CONNECTOR	1
2	PT06E-14-18S(476)	MATING CONNECTOR	1

NO.	PART NUMBER	DESCRIPTION	QTY.
1	PT02E-14-18P(027)	MATING CONNECTOR	1
2	PT06E-14-18S(476)	MATING CONNECTOR	1

NO.	PART NUMBER	DESCRIPTION	QTY.
1	PT02E-14-18P(027)	MATING CONNECTOR	1
2	PT06E-14-18S(476)	MATING CONNECTOR	1

NO.	PART NUMBER	DESCRIPTION	QTY.
1	PT02E-14-18P(027)	MATING CONNECTOR	1
2	PT06E-14-18S(476)	MATING CONNECTOR	1

NO.	PART NUMBER	DESCRIPTION	QTY.
1	PT02E-14-18P(027)	MATING CONNECTOR	1
2	PT06E-14-18S(476)	MATING CONNECTOR	1

NO.	PART NUMBER	DESCRIPTION	QTY.
1	PT02E-14-18P(027)	MATING CONNECTOR	1
2	PT06E-14-18S(476)	MATING CONNECTOR	1

NO.	PART NUMBER	DESCRIPTION	QTY.
1	PT02E-14-18P(027)	MATING CONNECTOR	1