

**MOTOR DATA @ 460 VAC (TRAP)**

MOTOR PARAMETERS	UNITS	VALUE
HORSEPOWER	HP	7.6
KILOWATTS	KW	5.7
MAX. OPERATING SPEED	N MAX	1750
SPEED @ RATED TORQUE	N RATED	1500
* CONTINUOUS RATED TORQUE @ 1500 RPM	IN-LBS [Nm]	320.0 [36.0]
* CONTINUOUS STALL TORQUE	IN-LBS [Nm]	360.0 [40.7]
CONTINUOUS LINE CURRENT	AMPS	13.6
PEAK TORQUE	IN-LBS [Nm]	1081.0 [122.2]
PEAK CURRENT	AMPS	40.6
MAX. THEORETICAL ACCEL.	RAD/SEC <sup>2</sup>	30,710
TORQUE SENSITIVITY	Kt [IN-LBS/AMP] [Nm/AMP]	25.8 [2.9]
BACK EMF (LINE TO LINE)	Vrms/Krpm	230.0
D.C. RESISTANCE (P-P)	OHMS	1.2
INDUCTANCE (P-P)	MILLIHENRIES	11.1
ROTOR INERTIA	Jm [IN-LBS-SEC <sup>2</sup> ] [Kg-M <sup>2</sup> ]	.0352 [0.00397]
STATIC FRICTION	Tf [IN-LBS] [Nm]	4.2 [.47]

\*25C AMBIENT WITH A MAXIMUM CASE TEMPERATURE OF 100°C ON MOTOR. MOTOR MOUNTED ON A 12" X 12" X 1/2" ALUMINUM HEATSINK. THERMOSTAT IN STATOR WINDINGS WILL OPEN IF WINDING TEMPERATURE EXCEEDS 155°C. THIS ALLOWS FOR AN APPROXIMATE +10% HEADROOM IN THE CONTINUOUS TORQUE RATING BEFORE THERMOSTAT OPENS.

**MECHANICAL NOTES:**

- AXIAL LOAD: 50 LBS MAX
- RADIAL LOAD: 150 LBS MAX @ 1" FROM FACE
- MOTOR SEALED TO IP65.
- MOTOR WEIGHT: 81 LBS. [36.7 Kg]
- MOTOR FINISH: BLACK EPOXY
- MOTOR OUTPUT SHAFT: STAINLESS STEEL
- MILLIMETERS (INCHES)

**ENCODER: (290-00052)**  
**OH48-2000P6-L6-SV**

**CONNECTION CHART**  
**MOTOR CONNECTOR:**  
SG3102E-22-22P(027)  
(270-00017)

PIN	WIRE FUNCTION	WIRE COLOR
A	ΦR	RED
B	ΦS	BLACK
C	ΦT	BLUE
D	PE GND	GRN/YEL

**ENCODER/THERM CONNECTOR:**  
PT02E-14-18P(027)  
(270-00024)

PIN	WIRE FUNCTION	WIRE COLOR
T	GROUND	BLACK
K	+5VDC	RED
B	CH A	BLUE
C	CH A	BLUE/BLK
N	CH B	GREEN
P	CH B	GRN/BLK
M	CH Z	YELLOW
U	CH Z	YEL/BLK
E	CH U	BROWN
R	CH U	BRN/BLK
F	CH V	GRAY
S	CH V	GRAY/BLK
G	CH W	WHITE
H	CH W	WHT/BLK
D	GND/CABLE	SHLD
A	THERM	BLACK
L	THERM	BLACK
J	GND	GRN/YEL

**MOTOR & HALL POSITION CHART**

HALL LEADS	BROWN	GRAY	WHITE
MOTOR LEADS	BLACK respect to RED	RED respect to BLUE	BLUE respect to BLACK

\*MOTOR ROTATION C/W (COUNTER CLOCKWISE)  
(LOOKING AT THE FACE OF THE MOTOR)

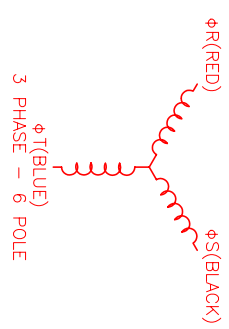
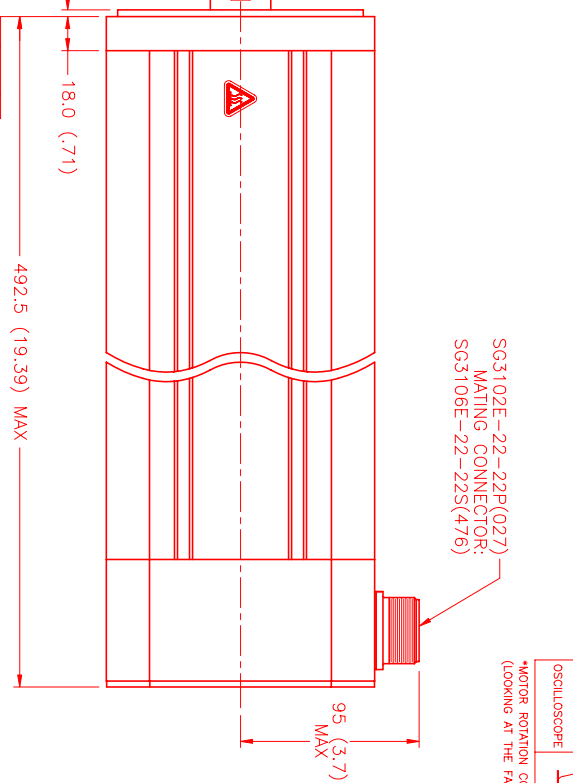
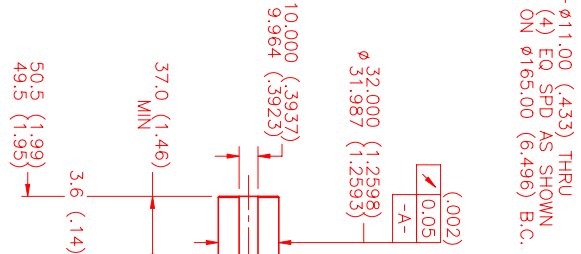
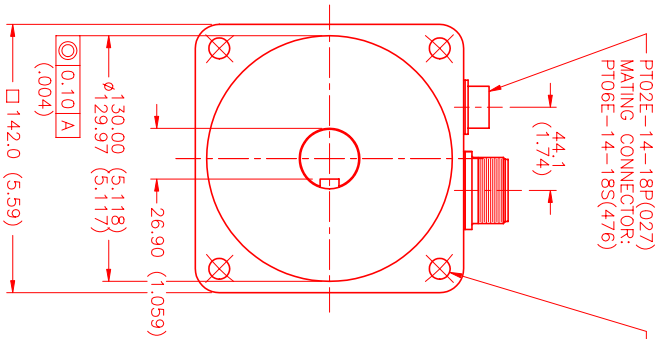

NO.	PART NUMBER	DESCRIPTION	QTY
1	SG3102E-22-22P(027)	MOTOR	1
2	PT02E-14-18P(027)	ENCODER/THERM CONNECTOR	1
3	SG3106E-22-22S(476)	MATING CONNECTOR	1

REV.	DESCRIPTION	DATE	APP.
PRELIMINARY		8/9/99	MVS

NO.	PART NUMBER	DESCRIPTION	QTY
1	SG3102E-22-22P(027)	MOTOR	1
2	PT02E-14-18P(027)	ENCODER/THERM CONNECTOR	1
3	SG3106E-22-22S(476)	MATING CONNECTOR	1

REV.	DESCRIPTION	DATE	APP.
PRELIMINARY		8/9/99	MVS

NO.	PART NUMBER	DESCRIPTION	QTY
1	SG3102E-22-22P(027)	MOTOR	1
2	PT02E-14-18P(027)	ENCODER/THERM CONNECTOR	1
3	SG3106E-22-22S(476)	MATING CONNECTOR	1

REV.	DESCRIPTION	DATE	APP.
PRELIMINARY		8/9/99	MVS

NO.	PART NUMBER	DESCRIPTION	QTY
1	SG3102E-22-22P(027)	MOTOR	1
2	PT02E-14-18P(027)	ENCODER/THERM CONNECTOR	1
3	SG3106E-22-22S(476)	MATING CONNECTOR	1

REV.	DESCRIPTION	DATE	APP.
PRELIMINARY		8/9/99	MVS

NO.	PART NUMBER	DESCRIPTION	QTY
1	SG3102E-22-22P(027)	MOTOR	1
2	PT02E-14-18P(027)	ENCODER/THERM CONNECTOR	1
3	SG3106E-22-22S(476)	MATING CONNECTOR	1

REV.	DESCRIPTION	DATE	APP.
PRELIMINARY		8/9/99	MVS

NO.	PART NUMBER	DESCRIPTION	QTY
1	SG3102E-22-22P(027)	MOTOR	1
2	PT02E-14-18P(027)	ENCODER/THERM CONNECTOR	1
3	SG3106E-22-22S(476)	MATING CONNECTOR	1

REV.	DESCRIPTION	DATE	APP.
PRELIMINARY		8/9/99	MVS

NO.	PART NUMBER	DESCRIPTION	QTY
1	SG3102E-22-22P(027)	MOTOR	1
2	PT02E-14-18P(027)	ENCODER/THERM CONNECTOR	1
3	SG3106E-22-22S(476)	MATING CONNECTOR	1

REV.	DESCRIPTION	DATE	APP.
PRELIMINARY		8/9/99	MVS

NO.	PART NUMBER	DESCRIPTION	QTY
1	SG3102E-22-22P(027)	MOTOR	1
2	PT02E-14-18P(027)	ENCODER/THERM CONNECTOR	1
3	SG3106E-22-22S(476)	MATING CONNECTOR	1

REV.	DESCRIPTION	DATE	APP.
PRELIMINARY		8/9/99	MVS

NO.	PART NUMBER	DESCRIPTION	QTY
1	SG3102E-22-22P(027)	MOTOR	1
2	PT02E-14-18P(027)	ENCODER/THERM CONNECTOR	1
3	SG3106E-22-22S(476)	MATING CONNECTOR	1

REV.	DESCRIPTION	DATE	APP.
PRELIMINARY		8/9/99	MVS

NO.	PART NUMBER	DESCRIPTION	QTY
1	SG3102E-22-22P(027)	MOTOR	1
2	PT02E-14-18P(027)	ENCODER/THERM CONNECTOR	1
3	SG3106E-22-22S(476)	MATING CONNECTOR	1

REV.	DESCRIPTION	DATE	APP.
PRELIMINARY		8/9/99	MVS

NO.	PART NUMBER	DESCRIPTION	QTY
1	SG3102E-22-22P(027)	MOTOR	1
2	PT02E-14-18P(027)	ENCODER/THERM CONNECTOR	1
3	SG3106E-22-22S(476)	MATING CONNECTOR	1

REV.	DESCRIPTION	DATE	APP.
PRELIMINARY		8/9/99	MVS

NO.	PART NUMBER	DESCRIPTION	QTY
1	SG3102E-22-22P(027)	MOTOR	1
2	PT02E-14-18P(027)	ENCODER/THERM CONNECTOR	1
3	SG3106E-22-22S(476)	MATING CONNECTOR	1

REV.	DESCRIPTION	DATE	APP.
PRELIMINARY		8/9/99	MVS

NO.	PART NUMBER	DESCRIPTION	QTY
1	SG3102E-22-22P(027)	MOTOR	1
2	PT02E-14-18P(027)	ENCODER/THERM CONNECTOR	1
3	SG3106E-22-22S(476)	MATING CONNECTOR	1

REV.	DESCRIPTION	DATE	APP.
PRELIMINARY		8/9/99	MVS

NO.	PART NUMBER	DESCRIPTION	QTY
1	SG3102E-22-22P(027)	MOTOR	1
2	PT02E-14-18P(027)	ENCODER/THERM CONNECTOR	1
3	SG3106E-22-22S(476)	MATING CONNECTOR	1

REV.	DESCRIPTION	DATE	APP.
PRELIMINARY		8/9/99	MVS

NO.	PART NUMBER	DESCRIPTION	QTY
1	SG3102E-22-22P(027)	MOTOR	1
2	PT02E-14-18P(027)	ENCODER/THERM CONNECTOR	1
3	SG3106E-22-22S(476)	MATING CONNECTOR	1

REV.	DESCRIPTION	DATE	APP.
PRELIMINARY		8/9/99	MVS

NO.	PART NUMBER	DESCRIPTION	QTY
1	SG3102E-22-22P(027)	MOTOR	1
2	PT02E-14-18P(027)	ENCODER/THERM CONNECTOR	1
3	SG3106E-22-22S(476)	MATING CONNECTOR	1

REV.	DESCRIPTION	DATE	APP.
PRELIMINARY		8/9/99	MVS

NO.	PART NUMBER	DESCRIPTION	QTY
1	SG3102E-22-22P(027)	MOTOR	1
2	PT02E-14-18P(027)	ENCODER/THERM CONNECTOR	1
3	SG3106E-22-22S(476)	MATING CONNECTOR	1

REV.	DESCRIPTION	DATE	APP.
PRELIMINARY		8/9/99	MVS

NO.	PART NUMBER	DESCRIPTION	QTY
1	SG3102E-22-22P(027)	MOTOR	1
2	PT02E-14-18P(027)	ENCODER/THERM CONNECTOR	1
3	SG3106E-22-22S(476)	MATING CONNECTOR	1

REV.	DESCRIPTION	DATE	APP.
PRELIMINARY		8/9/99	MVS

NO.	PART NUMBER	DESCRIPTION	QTY
1	SG3102E-22-22P(027)	MOTOR	1
2	PT02E-14-18P(027)	ENCODER/THERM CONNECTOR	1
3	SG3106E-22-22S(476)	MATING CONNECTOR	1

REV.	DESCRIPTION	DATE	APP.
PRELIMINARY		8/9/99	MVS

NO.	PART NUMBER	DESCRIPTION	QTY
1	SG3102E-22-22P(027)	MOTOR	1
2	PT02E-14-18P(027)	ENCODER/THERM CONNECTOR	1
3	SG3106E-22-22S(476)	MATING CONNECTOR	1

REV.	DESCRIPTION	DATE	APP.
PRELIMINARY		8/9/99	MVS

NO.	PART NUMBER	DESCRIPTION	QTY
1	SG3102E-22-22P(027)	MOTOR	1
2	PT02E-14-18P(027)	ENCODER/THERM CONNECTOR	1
3	SG3106E-22-22S(476)	MATING CONNECTOR	1

REV.	DESCRIPTION	DATE	APP.
PRELIMINARY		8/9/99	MVS

NO.	PART NUMBER	DESCRIPTION	QTY
1	SG3102E-22-22P(027)	MOTOR	1
2	PT02E-14-18P(027)	ENCODER/THERM CONNECTOR	1
3	SG3106E-22-22S(476)	MATING CONNECTOR	1

REV.	DESCRIPTION	DATE	APP.
PRELIMINARY		8/9/99	MVS

NO.	PART NUMBER	DESCRIPTION	QTY
1	SG3102E-22-22P(027)	MOTOR	1
2	PT02E-14-18P(027)	ENCODER/THERM CONNECTOR	1
3	SG3106E-22-22S(476)	MATING CONNECTOR	1

REV.	DESCRIPTION	DATE	APP.
PRELIMINARY		8/9/99	MVS

NO.	PART NUMBER	DESCRIPTION	QTY
1	SG3102E-22-22P(027)	MOTOR	1
2	PT02E-14-18P(027)	ENCODER/THERM CONNECTOR	1
3	SG3106E-22-22S(476)	MATING CONNECTOR	1

REV.	DESCRIPTION	DATE	APP.
PRELIMINARY		8/9/99	MVS