

MOTOR DATA @ 460 VAC (TRAP)		UNITS	VALUE
MOTOR PARAMETERS			
HORSEPOWER	HP RATED	Hp	9.8
KILOWATTS	KW RATED	KW	7.3
MAX. OPERATING SPEED	N MAX	RPM	3400
SPEED @ RATED TORQUE	N RATED	RPM	2800
* CONTINUOUS RATED TORQUE @ 2800 RPM	IN-LBS [Nm]		220.0 [24.8]
* CONTINUOUS STALL TORQUE	IN-LBS [Nm]		280.0 [31.5]
CONTINUOUS LINE CURRENT	AMPS (RMS/φ)		14.9
PEAK TORQUE	IN-LBS [Nm]		840.0 [94.4]
PEAK CURRENT	AMPS (RMS/φ)		44.7
MAX. THEORETICAL ACCEL.	RAD/SEC ²		30,769
TORQUE SENSITIVITY	Kt [IN-LBS/AMP/RMS/φ] [Nm/AMP/RMS/φ]		18.2 [2.1]
BACK EMF (LINE TO LINE)	Vrms/Krpm		115.0
D.C. RESISTANCE (P-P)	OHMS		.42
INDUCTANCE (P-P)	MILLIHENRIES		4.3
ROTOR INERTIA	Jm [IN-LBS-SEC ²] [Kg-M ²]		.0273 [0.0308]
STATIC FRICTION	Tf [IN-LBS] [Nm]		3.6 [.41]

*25°C AMBIENT WITH A MAXIMUM CASE TEMPERATURE OF 100°C ON MOTOR. MOTOR MOUNTED ON A 12" X 12" X 1/2" ALUMINUM HEATSINK. THERMOSTAT IN STATOR WINDINGS WILL OPEN IF WINDING TEMPERATURE EXCEEDS 155°C. THIS ALLOWS FOR AN APPROXIMATE +10% HEADROOM IN THE CONTINUOUS TORQUE RATING BEFORE THERMOSTAT OPENS.

MECHANICAL NOTES:

- AXIAL LOAD: 50 LBS MAX
- RADIAL LOAD: 150 LBS MAX @ 1" FROM FACE
- MOTOR SEALED TO IP65.
- MOTOR WEIGHT: 65 LBS. [29.5 Kg]
- MOTOR FINISH: BLACK EPOXY
- MOTOR OUTPUT SHAFT: STAINLESS STEEL
- MILLIMETERS (INCHES)

ENCODER: (290-00073)
OH48-2048P6-L6-5V

CONNECTION CHART
MOTOR CONNECTOR:
SG3102E-22-22P(027)
(270-00017)

PIN	WIRE FUNCTION	WIRE COLOR	LEADS
A	φR	RED	
B	φS	BLACK	
C	φT	BLUE	
D	PE GND	GRN/YEL	

ENCODER/THERM CONNECTOR:
PT02E-14-18P(027)
(270-00024)

PIN	WIRE FUNCTION	WIRE COLOR	LEADS
T	GROUND	BLACK	
K	+5VDC	RED	
B	CH A	BLUE	
C	CH A	BLUE/BLK	
N	CH B	GREEN	
P	CH B	GRN/BLK	
M	CH Z	YELLOW	
U	CH Z	YEL/BLK	
E	CH U	BROWN	
R	CH U	BRN/BLK	
F	CH V	GRAY	
S	CH V	GRAY/BLK	
G	CH W	WHITE	
H	CH W	WHT/BLK	
D	GND/GABLE	SHLD	
A	THERM	BLACK	
L	THERM	BLACK	
J	GND	GRN/YEL	

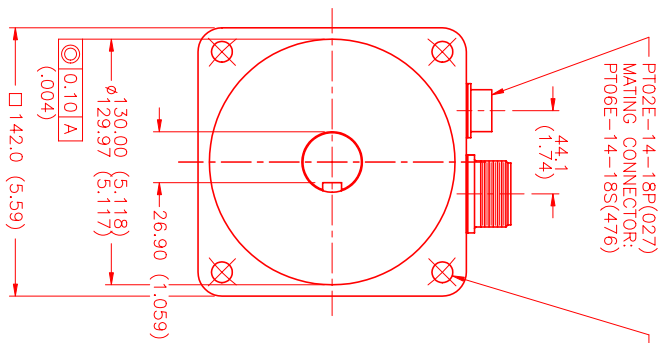

φ11.00 (4.33) THRU (4) EQ SPD AS SHOWN ON φ165.00 (6.496) B.C.

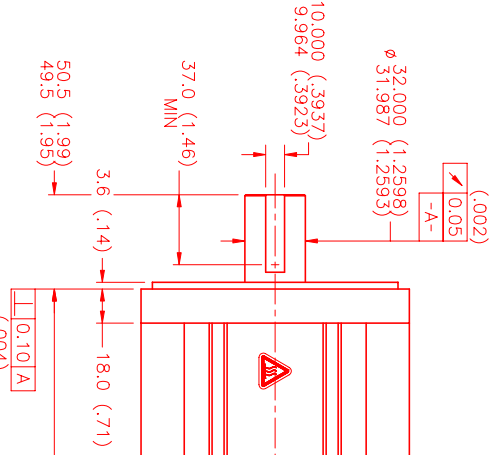

SG3102E-22-22P(027) MATING CONNECTOR: SG3106E-22-22S(476)

95 (3.7) MAX

*MOTOR ROTATION CCM (COUNTER CLOCKWISE) (LOOKING AT THE FACE OF THE MOTOR)

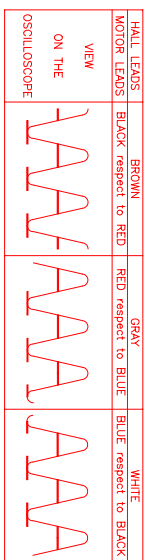

MOTOR & HALL POSITION CHART

HALL LEADS	BROWN	GRAY	WHITE
MOTOR LEADS	BLACK respect to RED	RED respect to BLUE	BLUE respect to BLACK

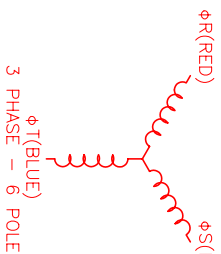

NO.	PART NUMBER	DESCRIPTION	QTY
1	MTS	MTS Systems Corporation Automation Division	1

REV	DESCRIPTION	DATE	APPD.
A	PRELIMINARY	12/19/01	LIN
A	E.C.O. - 643	3/11/02	AJS

DATE	BY	CHKD	APPD
11/19/01	LIN		

TITLE	MATERIAL	SCALE
"C"/SINE/460/MET/T2048/CONN	MPM1423CSU7Y1N	1/2:1